



Seismic Evaluation and Retrofit of Multi-Unit Wood-Frame Buildings With Weak First Stories

FEMA P-807 / May 2012



FEMA



Seismic Evaluation and Retrofit of Multi-Unit Wood-Frame Buildings With Weak First Stories

Prepared by

APPLIED TECHNOLOGY COUNCIL
201 Redwood Shores Parkway, Suite 240
Redwood City, California 94065
www.ATCouncil.org

Prepared for

FEDERAL EMERGENCY MANAGEMENT AGENCY
Michael Mahoney, Project Officer
Cathleen Carlisle, Project Monitor
Daniel Shapiro, Technical Monitor
Washington, D.C.

TASK ORDER CONTRACT MANAGEMENT
Christopher Rojahn (Project Executive Director)
Thomas R. McLane (Project Manager)
Jon A. Heintz (Project Quality Control Monitor)
William T. Holmes (Project Technical Monitor)

PROJECT REVIEW PANEL
Chris Poland (Chair)
Tony DeMascole
Laurence Kornfield
Bret Lizundia
Joan MacQuarrie
Andrew Merovich
Tom Tobin

PROJECT MANAGEMENT COMMITTEE
David Mar (Project Technical Director)
David Bonowitz
Kelly Cobeen
Dan Dolan
Andre Filiatrault
John Price

ANALYSIS CONSULTANTS
Maikol Del Carpio
Mike Korolyk

May 2012



Notice

Any opinions, findings, conclusions, or recommendations expressed in this publication do not necessarily reflect the views of the Applied Technology Council (ATC), the Department of Homeland Security (DHS), or the Federal Emergency Management Agency (FEMA). Additionally, neither ATC, DHS, FEMA, nor any of their employees, makes any warranty, expressed or implied, nor assumes any legal liability or responsibility for the accuracy, completeness, or usefulness of any information, product, or process included in this publication. Users of information from this publication assume all liability arising from such use.

Cover Photo: Near-collapse of typical weak-story wood-frame buildings in the 1989 Loma Prieta earthquake.

Foreword

The Federal Emergency Management Agency (FEMA) has the goal of reducing the ever-increasing cost that disasters inflict on our country. Preventing losses before they happen by designing and building to withstand anticipated forces from these hazards is one of the key components of mitigation, and is the only truly effective way of reducing the cost of disasters. As part of its responsibilities under the National Earthquake Hazards Reduction Program (NEHRP), and in accordance with the National Earthquake Hazards Reduction Act of 1977 (PL 94-125) as amended, FEMA is charged with supporting activities necessary to improve technical quality in the field of earthquake engineering. The primary method of addressing this charge has been supporting the investigation of seismic technical issues as they are identified by FEMA, the development and publication of technical design and construction guidance products, the dissemination of these products, and support of training and related outreach efforts.

In recent earthquake events, FEMA has observed that multi-unit wood-frame buildings with a weak first story represent a significant risk in highly seismic regions of the United States because of their high potential for collapse. This risk is magnified by the sheer numbers of these buildings that still exist and the numbers of people who occupy them. This collapse potential is due primarily to their soft or weak first-story walls, which have often been weakened by large numbers of openings such as garages or store front windows.

FEMA worked with ATC to develop these guidelines to address seismic retrofit requirements for weak-story wood-frame buildings in seismically active regions of the United States, with a particular focus on Northern and Southern California and the Pacific Northwest. The guidelines focus on multi-family, multi-story buildings with weak first stories, such as those damaged in the Marina District of San Francisco in the 1989 Loma Prieta earthquake, and apartment buildings with tuck-under parking, such as those damaged in Southern California in the 1994 Northridge earthquake.

These seismic retrofitting guidelines are the first to focus solely on the weak first story and to provide just enough additional strength to protect the first floor from collapse but not so much as to drive earthquake forces into the upper stories, placing them at risk of collapse. They are also the first to take into account the strength provided by existing non-structural walls. Both of

these steps will make seismic retrofitting more affordable. This methodology does presume, however, that the upper stories are basically regular and do provide enough strength to match the retrofitted first story.

FEMA is indebted to the Project Management Committee of David Mar (Project Technical Director), David Bonowitz, Kelly Cobeen, Dan Dolan, Andre Filiatrault, and John Price, for preparing this report, and to Mike Korolyk, who as the Analysis Consultant conducted the computer analyses to validate the guidelines. We also wish to thank the Project Review Panel of Chris Poland (Chair), Tony DeMascole, Laurence Kornfield, Bret Lizundia (ATC Board Representative), Joan MacQuarrie, Andrew Merovich, and Tom Tobin, who provided expert review and guidance throughout the developmental effort. Without their dedication and hard work, this project would not have been possible.

– Federal Emergency Management Agency

Preface

In May 2009 the Applied Technology Council (ATC), with funding from the Federal Emergency Management Agency (FEMA) under Task Order Contract HSFEHQ-08-D-0726, commenced development of simplified guidelines for the seismic retrofit of weak-story wood-frame buildings—one of several projects in a task order series to develop written guidance for FEMA on the creation, update, and maintenance of seismic evaluation and rehabilitation documents for existing buildings.

Multi-unit wood-frame buildings with a weak first story represent a significant risk in highly seismic regions of the United States, not only because of their damage and collapse potential, but also because of their size, prevalence and the high numbers of people who occupy them. In San Francisco, for example, approximately 4,400 older, pre-seismic-code, wood-frame residential buildings have been inventoried that contain five or more living units and are 3 or more stories in height (ATC, 2009a). Most of these buildings have potentially soft or weak ground floor (first story) walls, as do an expectedly high but unknown number of pre-seismic-code 3-to-5 story wood-frame commercial buildings, and similar buildings constructed after 1974 not included in the San Francisco inventory.

FEMA and ATC agreed that the retrofit guidelines development project should address seismic retrofit requirements for weak-story wood-frame buildings in seismically active regions of the United States, focusing primarily on Northern and Southern California and the Pacific Northwest. Configurations to be addressed included multi-family, multi-story buildings with weak first stories, such as those prevalent in San Francisco, and apartment buildings with tuck-under parking, such as those significantly damaged by the 1994 Northridge earthquake in Southern California. The project team was also charged with developing practical, model code provisions for seismic retrofit of weak-story wood-frame buildings that can be adopted by cities such as San Francisco and that are written to ensure that application and enforcement is uniform and enforceable.

This *Guidelines* document sets forth the framework for procedures for seismic evaluation and retrofit of weak-story wood-frame buildings. Throughout this document the term weak-story is used to describe a building's vulnerability, rather than soft-story. The reason is that while both

flexibility and strength contribute to the structure’s response, strength is the more dominant characteristic.

ATC is indebted to the ATC Project Management Committee, which consisted of David Mar (Project Technical Director), David Bonowitz, Kelly Cobeen, Dan Dolan, Andre Filiatrault, and John Price, for their efforts in researching and preparing this report; to Mike Korolyk, who served as the Analysis Consultant and conducted thousands of computer analyses to support and validate the guidelines; to Maikol Del Carpio, who assisted in the data analysis; and to the Project Review Panel, which consisted of Chris Poland (Chair), Tony DeMascole, Laurence Kornfield, Bret Lizundia (ATC Board Representative), Joan MacQuarrie, Andrew Merovich, and Tom Tobin, who provided expert review and guidance throughout the developmental effort. Thomas R. McLane served as Project Manager, William Holmes served as the Project Technical Monitor, and Peter Mork provided report production services. The affiliations of these individuals are provided in the list of Project Participants.

ATC also gratefully acknowledges the input, support, and guidance provided by Michael Mahoney (FEMA Project Officer), Cathleen Carlisle (FEMA Project Monitor), Robert Hanson (FEMA Subject Matter Expert), and Daniel Shapiro (FEMA Technical Monitor).

Jon A. Heintz
ATC Director of Projects

Christopher Rojahn
ATC Executive Director

Table of Contents

Foreword.....	iii
Preface.....	v
List of Figures.....	xiii
List of Tables	xxiii
Glossary	xxv
1. Introduction.....	1
1.1 Earthquake Risks of Multi-Unit Weak-Story Wood-Frame Buildings	1
1.2 Weak-Story Building Characteristics	2
1.2.1 The Critical Deficiency: A First Story Lacking Adequate Strength or Stiffness.....	3
1.3 Engineering Codes and Standards.....	4
1.3.1 The Guidelines as an Alternative	5
1.4 Purpose and Intended Use of the <i>Guidelines</i>	6
1.4.1 Policy Options	7
1.4.2 Selecting Performance Objectives.....	8
1.5 Validation	10
1.6 The Weak-Story Tool.....	10
1.7 <i>Guidelines</i> Organization and Content	10
2. Technical Overview.....	13
2.1 Statistical Basis.....	15
2.2 Modeling Actual and Surrogate Structures	15
2.2.1 The Surrogate Models	15
2.2.2 Characterizing an Existing Building	17
2.3 Acceptability Criteria	18
2.3.1 Performance Measure.....	18
2.3.2 Performance Objective.....	18
2.3.3 Relationship to Other Codes and Standards	19
2.4 Critical Deficiencies	21
2.5 Retrofit Design Philosophy	22
2.5.1 Cost-Effective, First-Story Retrofit.....	22
2.5.2 Bounded Design and Relative Strength.....	24
2.6 Limitations and Eligibility Requirements	25
2.6.1 General Eligibility Requirements.....	26
2.6.2 Upper-Story Eligibility Requirements.....	26
2.6.3 First-Story, Basement, and Foundation Eligibility Requirements.....	27
2.6.4 Floor and Roof Diaphragms Eligibility Requirements.....	28

3.	Simplified Evaluation.....	33
3.1	Purpose	33
3.1.1	Limitations.....	33
3.2	Simplified Evaluation Procedure	33
3.3	Building Survey	34
3.3.1	First-Story Survey.....	34
3.3.2	Upper-Story Survey	35
3.4	Building Characterization	35
3.4.1	Total Building Weight, W	36
3.4.2	Shear Strengths of First-Story Walls	36
3.4.3	Shear Strength of First Story	37
3.4.4	Center of Strength (COS_1) of First Story.....	37
3.4.5	Center of Strength (COS_2) of Upper Stories.....	38
3.4.6	Eccentricity	38
3.4.7	Simplified Torsion Coefficient, C_{Ts}	38
3.5	Simplified Evaluation of Seismic Performance.....	39
3.5.1	Site-Specific Spectral Acceleration Demand.....	39
3.5.2	Story-Height Factor, Q_s	40
3.5.3	Simplified Spectral Acceleration Capacity, S_{cs}	40
3.5.4	Comparison of Demand Versus Capacity.....	40
4.	Structure Characterization for Detailed Evaluation.....	41
4.1	Introduction.....	41
4.2	Wall Materials	42
4.3	Detailed Building Survey	42
4.4	Load-Drift Curves for Common Sheathing Materials	43
4.5	Wall Line Load-Drift Curves.....	47
4.5.1	Load-Drift Curves for Combinations of Sheathing Materials	49
4.5.2	Adjustment Factor for Openings in the Wall Line	50
4.5.3	Adjustment Factor for Overturning	53
4.5.4	Drift Ratio Adjustment for First-Story Wall Line Height	56
4.6	Determine Strength of Each Story	57
4.6.1	Translational Load-Drift Curve	57
4.6.2	Peak Strength.....	58
4.6.3	Drift Ratio at Peak Strength.....	59
4.6.4	Center of Strength.....	60
4.6.5	Torsional Eccentricity at the First Story	61
4.6.6	Load-Rotation Curve	61
4.6.7	Torsional Strength	63
4.6.8	Torsional Demand	64
4.7	Characteristic Coefficients.....	64
4.7.1	Normalized First-Story Strength.....	64
4.7.2	Normalized Upper-Story Strength.....	65
4.7.3	Weak-Story Ratio, A_w	66
4.7.4	Strength-Degradation Ratio, C_D	66
4.7.5	Torsion Coefficient, C_T	66
4.7.6	Story Height Factor, Q_s	67
5.	Detailed Evaluation	69
5.1	Evaluation Steps	69
5.2	Calculate the Median Spectral Acceleration Capacity.....	71

5.3	Calculate the Spectral Acceleration Capacity	72
5.4	Evaluate the Existing Structure	74
5.4.1	Compare the Spectral Acceleration Capacity with Site-Specific Demand.....	74
5.4.2	Calculating the Probability of Exceedance.....	75
6.	Retrofit	77
6.1	Retrofit Scope.....	77
6.2	Retrofit Strength.....	79
6.2.1	Estimated Minimum Required Strength of the Retrofitted First Story.....	80
6.2.2	Estimated Maximum Acceptable Strength of the Retrofitted First Story.....	81
6.2.3	Estimated Ranges of Acceptable Retrofit Strength	83
6.3	Locating Retrofit Elements	85
6.3.1	Retrofit Element Location to Minimize Torsion	86
6.3.2	Retrofit Element Location to Ensure Eligibility.....	87
6.4	Confirmed Performance of the Retrofitted Structure	88
6.4.1	Retrofits Intended to Satisfy the Performance Objective	90
6.4.2	Optimized Retrofits that Do Not Satisfy the Performance Objective	90
6.5	Retrofit Element Selection and Design	91
6.5.1	Load Path Components	93
6.5.2	Second Floor Diaphragm.....	93
6.5.3	Wood Structural Panel Shear Walls	93
6.5.4	Steel Moment Frames.....	94
6.5.5	Steel Braced Frames.....	94
6.5.6	Concrete or Reinforced Masonry Shear Walls.....	95
7.	Alternative Performance Assessment.....	97
7.1	Purpose	97
7.2	Assessment Background.....	97
7.3	Interstory Drift Limits	97
7.4	Spectral Acceleration Capacity	98
7.5	Estimating the Drift Limit Probability of Exceedance	99
	Appendix A: Guide to Weak-Story Tool.....	A-1
A.1	Introduction	A-1
A.2	Obtaining the Weak-Story Tool	A-1
A.3	System Requirements	A-1
A.4	Weak-Story Tool Installation	A-1
A.5	Basic Controls	A-2
A.6	General Building Properties and Geometry	A-2
A.7	CAD Interface	A-4
A.7.1	Analytical Entities	A-4
A.7.2	Non-Analytical Entities.....	A-4
A.7.3	Other CAD Tools	A-6
A.8	Defining Sheathing Assemblies	A-7
A.9	Assigning Level Properties and Laying Out Walls	A-11
A.9.1	The Shearwall Layout Tab	A-12
A.9.2	Shearwall Table.....	A-15

A.10	Evaluation and Retrofit Summary	A-15
A.10.1	Evaluation Data Tab	A-15
A.10.2	Backbone Curves Tab.....	A-17
A.10.3	Performance Data Tab	A-17
Appendix B:	Model Provisions for Mitigation Programs.....	B-1
B.1	Targeted Mitigation Programs	B-1
B.1.1	Planning and Program Development	B-2
B.1.2	Screening	B-3
B.1.3	Evaluation.....	B-3
B.1.4	Retrofit Prioritization.....	B-4
B.1.5	Retrofit.....	B-5
B.2	Program Performance Objectives	B-5
B.3	Model Provisions and Commentary	B-7
Appendix C:	Example Calculations.....	C-1
C.1	Simplified Evaluation (Chapter 3).....	C-3
C.2	Structure Characterization and Evaluation (Chapters 4 and 5)	C-7
C.3	Retrofit (Chapter 6).....	C-9
C.4	Torsion Calculations (Chapters 3 and 4)	C-17
Appendix D:	Characterization of Existing Materials	D-1
D.1	Introduction.....	D-1
D.2	Research Addressing Wall Bracing Materials	D-1
D.3	Load-Deflection Backbone	D-5
D.3.1	Plaster on Wood Lath	D-6
D.3.2	Horizontal Lumber Sheathing.....	D-8
D.3.3	Diagonal Lumber Sheathing	D-9
D.3.4	Stucco	D-11
D.3.5	Gypsum Wallboard.....	D-13
D.3.6	Plaster on Gypsum Lath.....	D-15
D.3.7	Wood Structural Panel Siding	D-17
D.3.8	Wood Structural Panel Sheathing	D-18
D.4	Recommended Descriptions of Wall Bracing Materials	D-29
D.5	Adjustment Factor for Combinations of Bracing Materials ..	D-30
D.6	Adjustment Factor for Openings in the Wall Line.....	D-32
D.7	Adjustment Factor for Overturning	D-33
D.8	Drift Adjustment for First-Story Wall-Line Height.....	D-34
D.9	Descriptions of Damage versus Drift.....	D-35
D.10	Recommended Future Research	D-54
Appendix E:	Detailed Analytical Background	E-1
E.1	Purpose	E-1
E.2	General.....	E-1
E.2.1	Overview and Limitations	E-1
E.2.2	Building Characterization.....	E-1
E.2.3	IDA Approach	E-2
E.2.4	Material Characterization	E-3
E.2.5	Performance Criteria.....	E-5
E.3	Modeling Details	E-7
E.3.1	Software.....	E-7

E.3.2	Typical Building Model	E-7
E.3.3	Hysteretic Damping.....	E-9
E.3.4	Viscous Damping	E-11
E.3.5	P-Delta.....	E-11
E.3.6	Accounting for Overturning Effects.....	E-11
E.4	Ground Acceleration Records	E-14
E.5	Translational Analyses	E-14
E.5.1	Analysis Flow.....	E-14
E.5.2	Median Performance	E-15
E.5.3	Interpolation for Intermediate Values of C_D	E-18
E.5.4	Adjustment for Uncertainty	E-20
E.5.5	Assessment and Probability of Exceedance	E-26
E.5.6	Retrofit Analyses.....	E-29
E.5.7	Effect of First-Story Retrofit	E-31
E.5.8	Estimating the Minimum Retrofit for Achieving Desired Performance	E-33
E.5.9	Wood-Sheathed Walls versus Moment Frame Retrofit	E-34
E.5.10	First-Story Height.....	E-36
E.6	Torsional Analyses	E-38
E.6.1	Discussion on Torsional Behavior	E-38
E.6.2	Torsion Coefficient, C_T	E-38
E.6.3	Modeling	E-39
E.6.4	Response-History Input.....	E-39
E.6.5	Assessing the Effect of Torsion.....	E-41
E.6.6	Simplified Torsion Coefficient, C_{Ts}	E-42

Appendix F: Validation of Analysis Methods.....F-1

F.1	Purpose	F-1
F.2	The Building Under Consideration	F-1
F.3	Differences in Scope of Analysis	F-2
F.3.1	Number of Stories	F-3
F.3.2	Sheathing Assemblies	F-3
F.4	Differences in Analytical Methods.....	F-3
F.4.1	Software	F-3
F.4.2	Viscous Damping	F-6
F.4.3	Backbone of Increasing Retrofit.....	F-7
F.5	Comparison of Results	F-8
F.5.1	Existing Building.....	F-9
F.5.2	Retrofitted Building.....	F-10
F.6	The Optimal Retrofit for Relative Strength.....	F-11
F.7	Conclusions	F-12

References..... G-1

Project Participants H-1

List of Figures

Figure 1-1	Photos illustrating near-collapse of typical weak-story wood-frame buildings in the 1989 Loma Prieta earthquake (left) and the 1994 Northridge earthquake (right)	1
Figure 1-2	Exploded views of three common multi-unit wood-frame residential building styles (roof system, top row; first story, bottom row).	3
Figure 2-1	Flow chart illustrating relationships between the <i>Guidelines</i> technical chapters	14
Figure 2-2	Plots of interstory drift versus shear force showing drift limits, Δ_L , used to develop fragility relationships from the surrogate models	17
Figure 2-3	Plan diagrams of three weak-story buildings.....	22
Figure 2-4	Schematic response of a corner building subject to torsion under loads in either direction, due to open wall lines on two sides at the first story.....	23
Figure 2-5	Schematic response of a building with a slightly weak story in the long direction and with torsion under loads in the long direction.	23
Figure 2-6	Plots illustrating floor displacements and drift ratios in a building with constant upper-story strength and varying first-story strength.....	25
Figure 2-7	Floor plan schematic showing limits on eccentricity between the center of strength (C_s) of each upper story and the center of mass (C_m) of the floor below it.	27
Figure 2-8	Floor plan schematic showing use of qualifying wall lines to meet diaphragm aspect ratio limits.....	29
Figure 2-9	Floor plan schematic showing locations of chords for cantilevered diaphragms that must satisfy eligibility rules.....	30
Figure 2-10	Floor plan schematic showing reentrant corner limits and use of qualifying wall lines to satisfy eligibility rules.	30
Figure 2-11	Floor plan schematic showing diaphragm openings that must be limited in size to satisfy eligibility requirements. ...	31

Figure 3-1	Illustration of wall lengths for an example wall line.....	37
Figure 4-1	Unit load-drift curves for sheathing materials with high-displacement capacity	45
Figure 4-2	Unit load-drift curves for sheathing materials with low-displacement capacity	45
Figure 4-3	Unit load-drift curves for all sheathing materials considered; note the large differences in both peak strength and displacement capacities.	46
Figure 4-4	Schematic of a typical wall assembly composed of various layers	49
Figure 4-5	Composite unit load-drift curve of a wall assembly comprising stucco, gypsum wallboard, and wood structural panels (structural plywood in figure), using 100% of the wood structural panel (WSP) sheathing plus 50% of the other sheathing materials.....	50
Figure 4-6	Composite unit load-drift curve of a wall assembly comprising stucco, gypsum wallboard and wood structural panels (structural plywood in figure), using 50% of the wood structural panel (WSP) sheathing plus 100% of the other sheathing materials	51
Figure 4-7	Controlling unit load-drift curve of a wall assembly comprising stucco, gypsum wallboard, and wood structural panels	51
Figure 4-8	Wall schematic showing variables in the adjustment factor for openings	52
Figure 4-9	Wall schematic showing variables in the calculated adjustment factor for overturning.....	55
Figure 4-10	Wall schematics and load-drift curves illustrating drift adjustment parameters for varying first-story wall line heights	57
Figure 4-11	Wall-plan schematic and depiction of the first-story load-drift curve as the sum of first story wall line load drift curves, y-direction	59
Figure 4-12	Wall-plan schematic showing location of center of strength at the first story.....	60
Figure 4-13	Wall-plan schematic and related torsional-load rotation curves illustrating how the first story load-rotation curve is computed	62

Figure 4-14	Wall-plan schematic depicting how the torsional demand on the first story is calculated.....	64
Figure 4-15	Load-drift curve depicting determination of strength-degradation ratio, C_D	67
Figure 5-1	Flowchart of typical evaluation procedure	70
Figure 5-2	Plot showing variation in spectral acceleration capacity (spectral capacity) as a function of different existing building characteristics.	73
Figure 6-1	Flowchart of typical retrofit procedure	78
Figure 6-2	Plot of spectral acceleration capacity (spectral capacity) versus strength of retrofitted first-story, for buildings with strong upper stories.....	82
Figure 6-3	Plot of spectral acceleration capacity (spectral capacity) versus strength of retrofitted first-story, for buildings with weak upper stories.	84
Figure 6-4	Floor plan schematic showing use of retrofit elements to meet diaphragm aspect ratio limits.	88
Figure 6-5	Floor plan schematic showing use of retrofit elements to satisfy re-entrant corner limits, east-west analysis.....	89
Figure 6-6	Floor plan schematic showing use of retrofit elements to satisfy re-entrant corner limits, north-south analysis.....	89
Figure 6-7	Simplified load-drift curve for steel Special Moment Frame retrofit elements	94
Figure 7-1	Illustration of drift limit definitions relative to two sheathing backbone curves with $C_D = 0.0$ and 1.0 , respectively.	98
Figure 7-2	Curves showing the relationship between as-built median spectral acceleration capacity, S_{μ} , and base-normalized upper-story strength for various weak-story ratios, A_w , and for the <i>Onset of Damage</i> set of drift limits.....	100
Figure 7-3	Curves showing the relationship between as-built median spectral acceleration capacity, S_{μ} , and base-normalized upper-story strength for various weak-story ratios, A_w , and for the <i>Onset of Damage</i> set of drift limits.....	100
Figure 7-4	Curves showing the relationship between as-built median spectral acceleration capacity, S_{μ} , and base-normalized upper-story strength for various weak-story ratios, A_w , and for the <i>Onset of Strength Loss</i> set of drift limits.	101

Figure 7-5	Curves showing the relationship between as-built median spectral acceleration capacity, $S_{\mu b}$ and base-normalized upper-story strength for various weak-story ratios, A_w , and for the <i>Onset of Strength Loss</i> set of drift limits.....	101
Figure A-1	Screenshot of contents of WeakStoryTool folder containing installation files.	A-2
Figure A-2	Screenshot of control buttons.....	A-2
Figure A-3	Screenshot of <i>General</i> control.....	A-3
Figure A-4	Reference geometrical input for sample building	A-6
Figure A-5	Screen-shot of object snap menu.....	A-7
Figure A-6	Screenshot of <i>Assemblies</i> control.....	A-8
Figure A-7	Screenshot of table of sheathing assemblies in <i>Assemblies</i> control.....	A-9
Figure A-8	Screenshot of form for defining assembly specifications for assemblies comprising standard sheathing layers.....	A-10
Figure A-9	Screenshot of form for defining custom load-drift curves for retrofit assemblies	A-11
Figure A-10	Screenshot of the <i>Shearwall Layout</i> tab in the <i>Levels</i> control for an example building	A-12
Figure A-11	Screenshot of the perforation calculator form in the <i>Levels/Shearwall Layout</i> control.....	A-14
Figure A-12	Screenshot of the <i>Evaluation Data</i> tab in the <i>Summary</i> control for an example building	A-16
Figure A-13	Screenshot of the <i>Backbone Curves</i> tab in the <i>Summary</i> control for an example building showing first-story load-drift curve before retrofit.....	A-18
Figure A-14	Screenshot of the <i>Backbone Curves</i> tab in the <i>Summary</i> control for an example building showing first-story load-drift curve after retrofit.	A-19
Figure A-15	Screenshot of the <i>Performance Data</i> tab in the <i>Summary</i> control for an example building	A-20
Figure A-16	Illustration of evaluation flow <i>Upward from S_{MS}</i>	A-21
Figure A-17	Illustration of evaluation flow <i>/Right from drift limit probability of exceedance</i>	A-21

Figure C-1	Street elevation of example building	C-1
Figure C-2	Example building first-floor plan.....	C-3
Figure C-3	Example building first-floor wall lengths and locations	C-7
Figure C-4	Example building upper-story wall lengths and locations	C-7
Figure D-1	Load-drift data for plaster on wood lath	D-7
Figure D-2	Load-drift data for horizontal wood sheathing.	D-9
Figure D-3	Load-drift data for diagonal lumber sheathing	D-11
Figure D-4	Load-drift data for stucco.....	D-13
Figure D-5	Load-drift data for gypsum wallboard	D-15
Figure D-6	Load-drift data for plaster on gypsum lath.....	D-16
Figure D-7	Load-drift data for wood structural panel siding.	D-17
Figure D-8	Load-drift data for wood structural panel 8d@6.....	D-20
Figure D-9	Load-drift data for wood structural panel 8d@4.....	D-22
Figure D-10	Load-drift data for wood structural panel 8d@3.....	D-24
Figure D-11	Load-drift data for wood structural panel 10d@6.....	D-25
Figure D-12	Load-drift data for wood structural panel 10d@4.....	D-27
Figure D-13	Load-drift data for wood structural panel 10d@2.....	D-29
Figure D-14	Plotted load-deflection curves for combined materials..	D-32
Figure D-15	Crack maps for stucco sheathing at 0.2% drift for (top) Wall 1 and (bottom) Wall 2.	D-36
Figure D-16	Crack maps for stucco sheathing at 0.4% drift for (top) Wall 1 and (bottom) Wall 2.	D-37
Figure D-17	Crack maps for stucco sheathing at 0.7% drift for (top) Wall 1 and (bottom) Wall 2.	D-38
Figure D-18	Crack maps for stucco sheathing at failure for (top) Wall 1 and (bottom) Wall 2	D-39
Figure D-19	Photos of characteristic cracking at 0.4% drift.	D-40
Figure D-20	Photos of characteristic cracking at 1.5% drift	D-41
Figure D-21	Photos of characteristic cracking at failure	D-42

Figure D-22	Crack maps for gypsum wallboard sheathing at 0.2% drift for (top) Wall 1 and (bottom) Wall 2.	D-43
Figure D-23	Crack maps for gypsum wallboard sheathing at 0.4% drift for (top) Wall 1 and (bottom) Wall 2.	D-44
Figure D-24	Crack maps for gypsum wallboard sheathing at 0.7% drift for (top) Wall 1 and (bottom) Wall 2.	D-45
Figure D-25	Crack maps for gypsum wallboard sheathing at failure for (top) Wall 1 and (bottom) Wall 2	D-46
Figure D-26	Photos of characteristic cracking at 0.4% drift.....	D-47
Figure D-27	Photos of characteristic cracking at 0.7% drift.....	D-48
Figure D-28	Photos of characteristic cracking at 1.5% drift.....	D-49
Figure D-29	Detailed photos of characteristic wall cracking at 1.5% drift.....	D-50
Figure D-30	Photos of characteristic cracking at 1.5% drift showing wallboard fastener popping	D-51
Figure D-31	Photos of characteristic cracking at completion of Forest Products Lab testing.	D-53
Figure E-1	Illustration of solution flow for Incremental Dynamic Analysis results	E-3
Figure E-2	Unit load-drift curves for materials with low-displacement capacity	E-4
Figure E-3	Unit load-drift curves for materials with high-displacement capacity	E-5
Figure E-4	Load-drift curves for archetypical material forms	E-6
Figure E-5	Schematics illustrating simplified building model bar elements.....	E-8
Figure E-6	Screen-shot of typical four-story simplified building model in Perform 3D.....	E-9
Figure E-7	Plot showing hysteretic behavior of simplified structure models constrained by the backbone curve for the high-displacement capacity material form.....	E-10
Figure E-8	Plot showing hysteretic behavior of simplified structure models constrained by the backbone curve for the low-displacement capacity material form.....	E-10

Figure E-9	Schematic of fiber model showing how wall elements were modeled to capture overturning restraint and allow uplift.....	E-12
Figure E-10	Schematic of building displaced shapes and related pushover curves used in study to determine overturning adjustment factor, Q_{ot}	E-13
Figure E-11	Plots of acceleration spectra for selected response-history records	E-14
Figure E-12	Flow chart used in translational analyses to optimize retrofit	E-16
Figure E-13	Curve fits for IDA results relating median spectral acceleration capacity (considering <i>Onset of Strength Loss</i> drift criteria) to base-normalized upper-story strength, A_U for various weak-story ratios A_W	E-17
Figure E-14	Curve fits for IDA results relating median spectral acceleration capacity (considering <i>Onset of Strength Loss</i> drift criteria) to base-normalized upper-story strength, A_U for various weak-story ratios A_W	E-17
Figure E-15	Curve fits for IDA results using <i>linear</i> interpolation model for C_D relating median spectral acceleration capacity (considering <i>Onset of Strength Loss</i> drift criteria) to base-normalized upper-story strength, A_U for various values of strength degradation ratio, C_D , and torsion coefficient, $C_T = 0.0$	E-18
Figure E-16	Curve fit for IDA results using cubic interpolation model for C_D relating median spectral acceleration capacity (considering <i>Onset of Strength Loss</i> drift criteria) to base-normalized upper-story strength, A_U , for various values of strength degradation ratio, C_D , and torsion coefficient, $C_T = 0.0$	E-19
Figure E-17	Plots of error data, as a function of strength degradation ratio, C_D , and base-normalized upper-story strength, A_U , for linear and cubic interpolation models for estimating median spectral acceleration capacity, S_μ	E-20
Figure E-18	Plots showing stiffness variations in high-displacement capacity materials (left) and low-displacement capacity materials (right) as a function of normalized force (acceleration response) and drift ratio.....	E-22
Figure E-19	Plots showing strength variations in high-displacement capacity materials (left) and low-displacement capacity materials (right) as a function of normalized force (acceleration response) and drift ratio.....	E-22

Figure E-20	Plots showing variations in drift at loss of strength in high-displacement capacity materials (left) and low-displacement capacity materials (right) as a function of normalized force (acceleration response) and drift ratio.....	E-22
Figure E-21	Plot showing effect of variation in stiffness, K , on median spectral capacity, S_{μ} , for various configurations of material form and upper-story strength ratio, A_U	E-24
Figure E-22	Plot showing effect of variation in peak strength, F_U , on median spectral capacity, S_{μ} , for various configurations of material form and upper-story strength ratio, A_U	E-25
Figure E-23	Plot showing effect of variation in drift at strength loss, D_L , on median spectral capacity, S_{μ} , for various configurations of material form and upper-story strength ratio, A_U	E-26
Figure E-24	Cumulative Distribution Function plots showing effect of increasing log-normal standard deviation, β , as a function of spectral acceleration response.....	E-27
Figure E-25	Plots of ratio of spectral acceleration capacity, S_c , at varying values of drift limit POE to median spectral capacity	E-28
Figure E-26	Lognormal distribution for standard deviations, $\beta = 0.5$ and 0.6 , for ratio of spectral acceleration demand to mean spectral acceleration capacity, over range of probabilities of exceedance, with linear fit (left) and the error (% difference) relative to the linear fit (right).....	E-29
Figure E-27	Retrofit backbone curves for various strength increments relative to the upper-story shear strength, V_U	E-30
Figure E-28	Plot illustrating hysteretic behavior of moment frame retrofit elements	E-30
Figure E-29	Plots of spectral acceleration capacity (spectral capacity) as a function of total first-story retrofitted strength, V_r , divided by upper-story strength, V_U , for four levels of base-normalized upper-story strength, A_U , varying initial pre-retrofit weak-story ratios, A_w , original construction having high-displacement capacity ($C_D = 1.0$), and <i>Onset of Strength</i> set of drift limits	E-31
Figure E-30	Plots of spectral acceleration capacity (spectral capacity) as a function of total first-story retrofitted strength, V_r , divided by upper-story strength, V_U , for four levels of base-normalized upper-story strength, A_U , varying initial	

	pre-retrofit weak-story ratios, A_w , original construction having low-displacement capacity ($C_D = 0.0$), and <i>Onset of Strength</i> set of drift limits.....E-32
Figure E-31	Plot of maximum strength of total retrofitted first-story, $V_{r,max}$, divided by upper-story strength, V_U , as a function of base-normalized upper-story strength, along with a plot of a linear-fit equationE-33
Figure E-32	Plots comparing retrofit performance for moment frame (M.F.) versus plywood wall retrofit, as a function of earthquake shaking intensity, for base-normalized upper-story strength, $A_U = 0.4$, and weak-story ratio, $A_W = 0.6$E-35
Figure E-33	Plots of median spectral acceleration capacity (spectral capacity) versus first-story height for four building models consideredE-36
Figure E-34	Plots of normalized median spectral acceleration capacity (spectral capacity) versus first-story height for four buildings considered.....E-37
Figure E-35	Plots of normalized median spectral acceleration capacity (spectral capacity) versus first-story height for four buildings considered with linear fitE-37
Figure E-36	Schematic illustration of floor plans and values of weak-story ratio, A_w , used in Perform 3D models of unretrofitted buildings for various torsion coefficients, C_TE-40
Figure E-37	Schematic illustration of floor plans and values of weak-story ratio, A_w , used in Perform 3D models of retrofitted buildings for various torsion coefficients, C_TE-40
Figure E-38	Plots of spectral acceleration capacity reduction versus torsion coefficient, C_T , for the <i>Onset of Strength Loss</i> set of drift criteria, considering the longitudinal direction for various values of weak-story ratio, A_wE-41
Figure E-39	Plots of spectral acceleration capacity reduction versus C_T , for the <i>Onset of Strength Loss</i> set of drift criteria, considering the transverse direction for various values of weak-story ratio, A_wE-42
Figure E-40	Illustration of the simplified torsional strength, T_sE-43
Figure F-1	CUREE Apartment Building used in ATC-71-1 Task 2 Analysis.....F-2

Figure F-2	Hysteretic behavior of wood-framed elements in SAWS.....	F-4
Figure F-3	Hysteretic behavior of moment frame elements in SAWS.....	F-4
Figure F-4	Hysteretic behavior of elements emulating wood-frame walls in Perform-3D, where the degradation ratio, $CD = 0.0$	F-5
Figure F-5	Hysteretic behavior of elements emulating wood-frame walls in Perform-3D, where the degradation ratio, $CD = 1.0$	F-5
Figure F-6	Hysteretic behavior elements emulating ductile moment frames in Perform-3D.....	F-6
Figure F-7	Backbone curves for varying retrofits modeled in the <i>Task 2 Analysis</i>	F-7
Figure F-8	Backbone curves for varying retrofits modeled in the <i>Broad-Scope Analysis</i>	F-8
Figure F-9	Comparison of selected backbone curves for varying retrofits modeled	F-8
Figure F-10	Comparison of analysis results for the existing building ...	F-9
Figure F-11	Comparison of analysis results for the building with retrofit strength of V_y/V_2 of 0.2 for Task 2 and emulation of <i>Task 2</i> and V_u/V_2 of 0.2 for the <i>Broad-Scope Analysis</i>	F-10
Figure F-12	Comparison of backbone curves for <i>Task 2</i> retrofit set with ratio $V_y/V_2 = 0.2$, and <i>Broad-Scope Analysis</i> retrofit set at $V_u/V_2 = 0.4$	F-11
Figure F-13	Comparison of results for <i>Task 2</i> retrofit set with ratio $V_y/V_2 = 0.2$, and <i>Broad-Scope</i> retrofit set at $V_u/V_2 = 0.4$..	F-12

List of Tables

Table 1-1	Embedded and Alternative Criteria in the <i>Guidelines</i>	8
Table 2-1	Comparison of the <i>Guidelines</i> to 2009 IEBC Chapter A4...	20
Table 3-1	Drift Limit Probability of Exceedance (<i>POE</i>) Adjustment Factors for Low-Displacement Capacity Elements	34
Table 3-2	Strength Data for Sheathing Materials Considered.....	35
Table 4-1	Load-Drift Curve Data for Sheathing Materials [pounds/linear foot].....	44
Table 4-2	Simplified Adjustment Factor for Overturning.....	53
Table 5-1	Drift Limit Probability of Exceedance (<i>POE</i>) Adjustment Factors.....	73
Table 7-1	Curve-Fitting Coefficients (γ_U , α_U , and α_W) for Calculating Spectral Acceleration Capacity	98
Table C-1	Example Building Properties	C-2
Table C-2	Example Building Weights.....	C-4
Table C-3	Example Building Spectral Capacity Calculated in Various Ways.....	C-6
Table D-1	Load-Drift Data for Plaster on Wood Lath	D-6
Table D-2	Load-Drift Data for Horizontal Wood Sheathing	D-8
Table D-3	Load-Drift Data for Diagonal Lumber Sheathing	D-10
Table D-4	Load-Drift Data for Stucco	D-12
Table D-5	Load-Drift Data for Gypsum Wallboard.....	D-14
Table D-6	Load-Drift Data for Plaster on Gypsum Lath	D-16
Table D-7	Load-Drift Data for Wood Structural Panel Siding	D-17
Table D-8	Load-Drift Data for Wood Structural Panel 8d@6.....	D-19
Table D-9	Load-Drift Data for Wood Structural Panel 8d@4.....	D-21
Table D-10	Load-Drift Data for Wood Structural Panel 8d@3.....	D-23

Table D-11	Load-Drift Data for Wood Structural Panel 10d@6	D-25
Table D-12	Load-Drift Data for Wood Structural Panel 10d@4	D-26
Table D-13	Load-Drift Data for Wood Structural Panel 10d@2	D-28
Table D-14	Recommended Values for Estimated Capacity and Variability	D-30
Table D-15	Data for Combined Materials	D-31
Table D-16	Descriptions of Damage States and Drifts	D-52
Table E-1	Drift Criteria, Interstory Drift Ratios in Percent	E-7
Table E-2	Computed Material Statistics: β_x = Log-Normal Standard Deviation of Variable x , and ρ_{xy} = Correlation Coefficient of the Natural Logarithm of Variable x and y	E-23
Table E-3	Modified Material Statistics: β_x = Log-Normal Standard Deviation of Variable x , and ρ_{xy} = Correlation Coefficient of the Natural Logarithm of Variable x and y	E-24
Table E-4	Summary of Composite Log-Normal Standard Deviation, β_{total} (also known as β)	E-26

Acronyms

ASCE	American Society of Civil Engineers
ATC	Applied Technology Council
BSE-2	Basic Safety Earthquake level 2, an earthquake hazard level with ground motions have a 2% probability of being exceeded in 50 years
CalTech	California Institute of Technology
CUREE	Consortium of Universities for Research in Earthquake Engineering
EERI	Earthquake Engineering Research Institute
FEMA	Federal Emergency Management Agency
IEBC	<i>International Existing Building Code</i>
MCE	Maximum Considered Earthquake
OD	onset of damage
OSL	onset of strength loss
POE	Probability of Exceedance, as used extensively throughout the <i>Guidelines</i> in the phrase, “drift limit <i>POE</i> ” (i.e., drift limit Probability of Exceedance)
SEI	Structural Engineering Institute of ASCE
WSP	wood structural panel

Symbol Definitions

A_i	= area of wall opening i .
A_i	= peak strength of story i divided by the total seismic weight of the building (base-normalized strength).
$A_{1,x}$	= peak strength of the first story divided by the total seismic weight of the building (base-normalized strength), in the x-direction.
A_U	= base-normalized upper-story strength, calculated separately for each direction.

- A_{Ux} = base-normalized upper-story strength, in the x-direction.
- A_W = weak-story ratio, calculated separately for each direction.
- C_D = strength degradation ratio, calculated separately for each direction.
- $C_{D,x}$ = strength degradation ratio, in the x-direction.
- $C_{D,y}$ = strength degradation ratio, in the y-direction.
- C_i = peak strength of story i divided by the seismic weight carried by story i (story-normalized strength).
- $C_{1,x}$ = peak strength of the first story divided by the seismic weight carried by the first story (story-normalized strength), in the x-direction.
- C_T = torsion coefficient.
- C_{Ts} = simplified torsion coefficient.
- C_U = minimum of the story-normalized story strengths of any of the upper stories, calculated separately for each direction.
- $C_{U,x}$ = minimum of the story-normalized story strengths of any of the upper stories, in the x-direction.
- COS_i = plan location, in x and y coordinates, of the center of strength of story i .
- COS_1 = plan location, in x and y coordinates, of the center of strength of the first story.
- COS_2 = plan location, in x and y coordinates, of the center of strength of the upper stories.
- $COS_{2,x}$ = x coordinate of the center of strength of the second story.
- $COS_{2,y}$ = y coordinate of the center of strength of the second story.
- $COS_{1r,x}$ = x coordinate of the center of strength of the retrofitted first story.
- $COS_{1r,y}$ = y coordinate of the center of strength of the retrofitted first story.
- d_w = distance at which wall line w acts to contribute to a story's twist.
- $d_{w,x}$ = distance between the center of strength of wall w , and the center of strength of the first story, in the x -direction.
- $d_{w,y}$ = distance between the center of strength of wall w , and the center of strength of the first story, in the y -direction.

- D = uniform horizontal displacement at top of wall in direction of wall.
- e_x, e_y = x and y components, respectively, of the torsional eccentricity.
- f_w = load-drift curve for wall line w .
- $f_{v,w}$ = total shear strength of wall line w .
- $f_{v,w,x}$ = component of shear strength of wall w , in x -direction.
- $f_{v,w,y}$ = component of shear strength of wall w , in y -direction.
- $f_w(\delta_j)$ = load-drift curve for wall line w , at drift ratio increment δ_j .
- $f_w(\delta_{jh})$ = load-drift curve for wall line w , at drift ratio increment δ_{jh} , the drift ratio increment adjusted for wall line height, h .
- F_i = load-drift curve for story i , calculated separately for each direction.
- h = floor-to-ceiling wall height of first-story wall line.
- h_w = floor-to-ceiling height of wall line w .
- H = maximum floor-to-ceiling height of any first-story wall.
- H_{F1} = maximum story height of the first story, floor to floor.
- H_1 = floor-to-ceiling height of the tallest first story wall line, determined separately in each direction.
- i = a subscript index indicating floor or story; story i is between floor i and floor $i+1$.
- j = twist angle index ranging from 0 to 10.
- L_D = moment arm for concentrated load, P_D .
- L_w = length of wall line w .
- L_x = overall building dimension in the x direction.
- L_y = overall building dimension in the y direction.
- M_{ot} = overturning moment demand on the wall line.
- M_r = overturning resistance capacity of the wall line.
- N_s = total number of stories in the building.
- $p_{w,x}$ = x -coordinate of the center of wall w .
- $p_{w,y}$ = y -coordinate of the center of wall w .
- POE = probability of exceedance.

- P_D = concentrated dead load tributary to wall line.
- Q_{open} = adjustment factor for openings in a wall line.
- Q_{ot} = adjustment factor for overturning of a wall line.
- Q_s = story height factor for the first story, calculated separately for each principal direction.
- S_c = spectral acceleration capacity, calculated separately for each direction.
- S_{c0} = spectral acceleration capacity (adjusted for drift limit *POE*) for materials with low-displacement capacity (C_D value of 0.0).
- S_{c1} = spectral acceleration capacity (adjusted for drift limit *POE*) for materials with high-displacement capacity (C_D value of 1.0).
- S_{cs} = simplified spectral acceleration capacity.
- $S_{cs,x}$ = simplified spectral acceleration capacity, in x-direction.
- $S_{cs,y}$ = simplified spectral acceleration capacity, in y-direction.
- S_d = spectral acceleration demand.
- S_{MS} = default (embedded) spectral acceleration demand; the maximum considered earthquake (MCE) spectral acceleration for short periods from ASCE/SEI 7-05.
- S_μ = median spectral acceleration capacity.
- $S_{\mu0}$ = median spectral acceleration capacity for strength degradation ratio, $C_D = 0.0$.
- $S_{\mu1}$ = median spectral acceleration capacity for strength degradation ratio, $C_D = 1.0$.
- t_i = load-rotation curve for story i .
- T_i = torsional strength of story i .
- T_1 = torsional strength of first story.
- T_{HD} = tension ultimate capacity of tie-down hardware, if applicable.
- $v_{a,w}$ = unit shear strength of wall assembly for wall line w .
- v_s = unit shear strength of sheathing material
- $v_w(\delta_j)$ = unit load-drift curve for the wall line's combination of sheathing materials at drift ratio increment, δ_j .

- $v_w(\delta_{jh})$ = unit load-drift curve for the wall line's combination of sheathing materials at drift ratio increment, δ_{jh} , the drift ratio increment adjusted for wall line height, h .
- $V_{1,x}$ = peak first-story strength, in the x -direction.
- $V_{1,y}$ = peak first-story strength, in the y -direction.
- V_i = story strength of story i , calculated separately for each direction.
- V_{1r} = story strength of the retrofitted first story, calculated separately for each direction.
- $V_{r,min}$ = estimated minimum required strength of the retrofitted first story.
- V_w = peak shear strength from the load-drift curve of the wall line, adjusted for openings.
- V_U = story strength of the upper story that determines the value of C_U .
- w = a subscript index indicating a single wall line.
- w_D = uniform dead load tributary to wall line.
- W = total seismic weight of the building, equal to the sum of all the tributary floor weights.
- W_i = tributary floor weight of floor i .
- W_j = tributary floor weight of floor j .
- x = a subscript index indicating the x -direction, or in some cases, one of two principal directions.
- y = a subscript index indicating the y -direction.
- $\alpha_{POE,0}$ = drift limit probability of exceedance (POE) adjustment factor for a C_D value of 0.0.
- $\alpha_{POE,1}$ = drift limit probability of exceedance (POE) adjustment factor for a C_D value of 1.0.
- α_U = curve fitting coefficient used to calculate S_c , provided for C_D values of 1.0 and 0.0, onset of strength loss (OSL) drift limits, and onset of damage (OD) drift limits.
- α_W = curve fitting coefficient used to calculate S_c , provided for C_D values of 1.0 and 0.0, onset of strength loss (OSL) drift limits, and onset of damage (OD) drift limits.
- Δ_i = drift at which the story strength of story i occurs, in each direction.

- γ_U = curve fitting coefficient used to calculate S_c , provided for C_D values of 1.0 and 0.0, onset of strength loss (OSL) drift limits, and onset of damage (OD) drift limits.
- τ_1 = first story torsional demand.
- δ_j = drift ratio at increment j .
- δ_{jh} = drift ratio at increment j , adjusted for wall height, h ,
- θ = maximum angle of twist, in radians.
- θ_j = twist angle j .

Multi-unit buildings make up a large portion of the housing stock of any city. In the western United States, thousands of multi-unit buildings are three- or four-story wood-frame structures designed and built to outdated seismic standards. The worst ones, with collapse-prone weak first stories, pose enormous safety risks to tenants, financial risks to owners, and recovery risks to local, state and federal governments.

1.1 Earthquake Risks of Multi-Unit Weak-Story Wood-Frame Buildings

Recent earthquakes have proven the vulnerability of wood-frame residential buildings with weak first stories (Figure 1-1). The critical damage pattern, involving the concentration of lateral deformation within a relatively open first story, was seen as early as the 1971 San Fernando earthquake. In the 1989 Loma Prieta earthquake, six of the seven collapsed buildings in San Francisco's Marina District were four-story corner apartment buildings with first-story parking (Harris and Egan, 1992). In the 1994 Northridge earthquake, perhaps two hundred such buildings, containing thousands of residential units, suffered severe damage or collapsed (EERI, 1996, Chapter 6).

Despite this history, thousands of these buildings remain. In San Francisco alone, about 2,800 buildings providing housing to 58,000 residents appear to have collapse-vulnerable open first stories (ATC, 2009a). These are



Figure 1-1 Photos illustrating near-collapse of typical weak-story wood-frame buildings in the 1989 Loma Prieta earthquake (left) and the 1994 Northridge earthquake (right).

buildings with more than 80% open area on one first-story wall or more than 50% open area on two adjacent first-story walls. In addition, there are (a) another 1,600 buildings in the same category (buildings with three or more stories and five or more residential units) that have smaller percentages of open area on the first-story walls, (b) an expectedly high but unknown number of 3-to-5 story pre-seismic-code commercial wood-frame buildings with potentially weak first stories, and (c) similar buildings constructed after 1974 not included in the San Francisco inventory.

Though anyone in a collapsing building is at risk, the primary safety risk in a weak-story building is to anyone who happens to be in the first story when the earthquake strikes. A recent evaluation program in Berkeley found that about three-quarters of the buildings considered had at least one first-story residential unit, and another ten percent had first-story shops or offices (Bonowitz and Rabinovici, in preparation). Adding to the safety risk is the financial risk to owners and tenants of weak-story buildings.

Jurisdictions with hundreds or thousands of these buildings face problems of a different sort. Even if only a fraction collapse, the resulting damage and debris will strain a city's ability to perform search and rescue, transport the injured to hospitals, and fight fires started by inevitable rupture to gas lines and short circuits in electrical systems. Many buildings that do not collapse will be unsafe to occupy until repairs are made, increasing the demand for shelter beds and slowing recovery overall. Even where multi-unit buildings are not a large portion of the total housing stock, they might provide a disproportionate percentage of a city's low-income housing; extensive damage within just that category affects recovery of the work force and strains social services. For these and other reasons, weak-story residential buildings have been put forward as a top priority for mitigation (ATC, 2009a; SPUR, 2009).

1.2 Weak-Story Building Characteristics

Not every wood-frame multi-unit building has a weak story. This particular vulnerability is found most often where population density and land values led to mixed-use construction. In many such instances, some or all of the residential units have been moved to the upper stories to make space for parking or, on busier streets, for first-story shops and offices. But mixed uses alone did not cause weak stories; the problem arose because the non-residential first-story uses called for different column grids or wall layouts and did not require the same number of room partitions as the apartments above. The result was buildings with distinct lateral stiffness and strength differences between their first story and their upper stories (Figure 1-2).

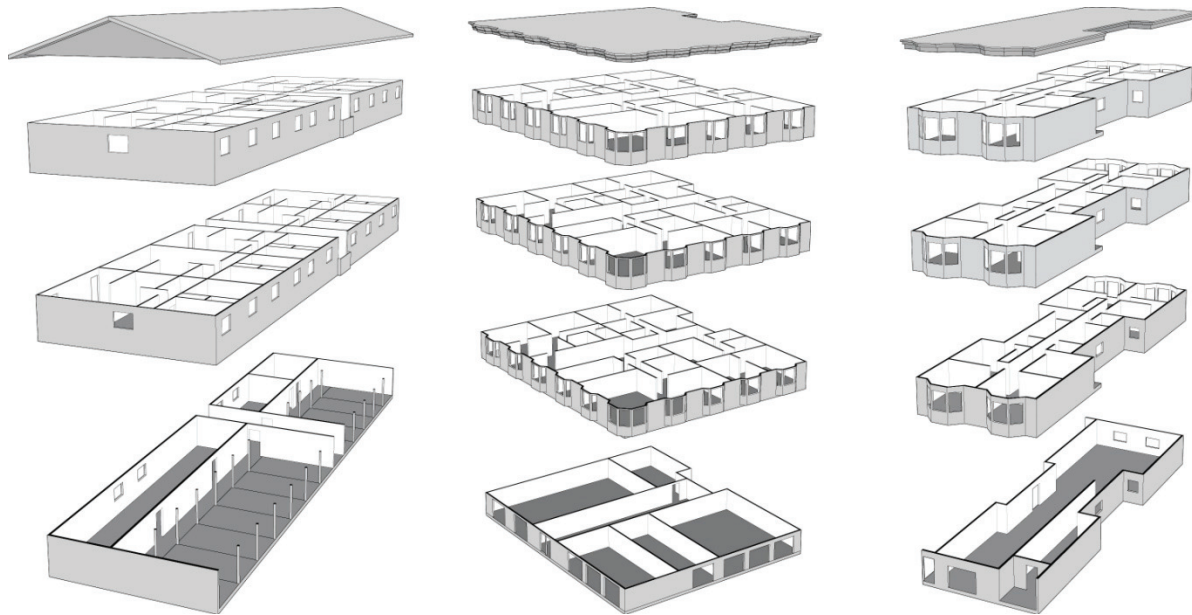

Figure 1-2 Exploded views of three common multi-unit wood-frame residential building styles (roof system, top row; first story, bottom row). The left building is characteristic of 1950s or 1960s buildings with tuck-under parking accessible through a long open side. The middle building is a 1920s era corner building with garage doors lining large portions of both street-facing sides. The right building is a midblock configuration with typically few first-story transverse walls. In all cases, note the relatively high density of walls and partitions above the first story.

In San Francisco, these differences can be seen even in Victorian and Edwardian era buildings with tall first-story storefronts, some of which pre-date the 1906 earthquake. A 1920s building boom saw the construction of hundreds, perhaps thousands, of apartment buildings with first stories dedicated to car parking. The Marina District buildings that collapsed in 1989 were from this era.

Most of the buildings addressed by these *Guidelines*, however, are in more recent suburban developments, such as those in the San Fernando Valley, where low-rise apartment houses addressed a burgeoning demand beginning in the 1950s (EERI, 1995, Chapter 10). Even in Berkeley, which grew rapidly after the 1906 earthquake and during World War II, about 70 percent of the multi-unit buildings evaluated in a recent program were built between 1950 and 1970 (Bonowitz and Rabinovici, in preparation).

1.2.1 The Critical Deficiency: A First Story Lacking Adequate Strength or Stiffness

Earthquake shaking imposes lateral (sideways) forces and deformations on a building. When the building's first story lacks adequate strength or stiffness, the lateral deformations become concentrated within that story, instead of being distributed efficiently over the height of the structure. When the

available first-story walls are not positioned effectively, as when one or two sides are essentially open to facilitate parking, the first-story deformations can be compounded by the building's tendency to twist. In structures built of obsolete or archaic materials, excessive deformation leads to damage and, in extreme cases, collapse.

Whether designers of the 1920s and 1960s recognized the structural effects of an open first story is unclear. If measures were taken to compensate for the open first story, they were not uniform. Building codes did not address “irregular” structures until the 1970s, and those early provisions left much to the judgment of the engineer (ATC, 1984). Quantitative definitions (and prohibitions) of weak-story and soft-story irregularities were not codified until the 1988 *Uniform Building Code* (ICBO, 1988).

1.3 Engineering Codes and Standards

Building codes for new construction, while often applied to existing structures, are often unsuited to that purpose. The prescriptive rules of the code make assumptions about structural materials, the configuration of structural elements, and the quality of construction that are not satisfied by many existing buildings. Further, the code's purpose is to check the compliance of a design relative to fixed rules; it is not especially helpful for evaluating non-compliant conditions in relative terms or for gauging a design against alternative objectives.

Codes and standards for use with existing buildings do exist. There is even a set of code provisions intended specifically for the buildings addressed by these *Guidelines*. All have some shortcomings, however, as described below.

Appendix Chapter A4 of the *International Existing Building Code* (IEBC), titled “Earthquake Hazard Reduction in Existing Wood-Frame Residential Buildings with Soft, Weak or Open-Front Walls” (ICC, 2009b), is similar to the code for new construction, only with reduced design forces, a focus on the critical first story, and some rules to guide application to existing conditions. While useful and adopted by several California jurisdictions with nascent mitigation programs (including San Francisco, Oakland, Berkeley, and Alameda), Chapter A4 mostly covers the design of retrofit elements but does not yield a careful evaluation of existing conditions. As a code-based document, it is more about assuring compliance than measuring performance. Its retrofit provisions also ignore the possibility of over-strengthening the first story.

The evaluation standard known as ASCE/SEI 31, *Seismic Evaluation of Existing Buildings* (ASCE, 2003), is based on identifying a building's

potential deficiencies and using three levels of analysis to determine if the deficiencies are significant to the performance of the structure. While the presence of weak-story or open-front conditions are tagged as potential deficiencies, the analysis methods cited to determine their significance are quite conservative. ASCE/SEI 31 also does not cover retrofit design directly.

The retrofit standard known as ASCE/SEI 41, *Seismic Rehabilitation of Existing Buildings* (ASCE, 2006b), is a comprehensive document suitable for both evaluating and retrofitting these irregular structures. ASCE/SEI 41 is a tool box of procedures requiring application by a knowledgeable specialist and its breadth and complexity can make it cumbersome, as it does not address specific building or structure types the way IEBC Chapter A4 and ASCE/SEI 31 do. It also lacks the practicality of Chapter A4, which acknowledges the value of a first-story-only retrofit.

The existing codes and standards share two other shortcomings as well. First, they lack a consistent set of default strength and stiffness values for archaic or non-conforming materials. Second, they lack the means to make the kind of quick screening assessment a city-wide mitigation program often needs.

1.3.1 The Guidelines as an Alternative

The Federal Emergency Management Agency (FEMA) and the Applied Technology Council (ATC) have developed these *Guidelines* as an alternative to current codes and standards. The *Guidelines* present a methodology that combines the thoroughness of a detailed analysis with a simplified procedure and a focus on cost-effective evaluation and retrofit. The features of the method include the following:

- Like ASCE/SEI 41, the method is based on a sophisticated understanding of nonlinear material behavior and structural response. It therefore allows a more complete understanding of the existing structure than a code-based procedure such as IEBC Chapter A4.
- Unlike ASCE/SEI 41, the method entails a simplified procedure for one vulnerable building type with a dominant deficiency. An engineer need only characterize the structure's materials and geometry, then compare key parameters to the results of nonlinear analyses of surrogate structures already performed and summarized by the *Guidelines*.
- Like IEBC Chapter A4 (but unlike ASCE/SEI 31 and ASCE/SEI 41), the method focuses on the dominant collapse-vulnerable deficiency, considering cost-effective retrofit solutions that require work only in the first story, thereby minimizing disruption to upper story occupants.

- Unlike Chapter A4, the method considers the consequences of over-strengthening the first story. In certain buildings, adding too much strength to the weak first story can lead to excessive damage in an upper story. The *Guidelines* procedure finds those cases and limits the retrofit appropriately.
- Unlike any of the current codes and standards, the method quantifies performance in probabilistic terms, as opposed to giving a pass-fail grade. The probabilistic method, based on estimated fragility, supports a wider range of mitigation policy options.

The *Guidelines* also use the latest and most consistent knowledge base of applicable test results, filling a gap in current practice.

From the code official's perspective, perhaps the most significant feature of the *Guidelines*' methodology is that it does not require the engineer to develop and analyze a complete nonlinear model of the specific building in question. Instead, it relies on the statistical representation of hundreds of surrogate models already analyzed in advance (see Chapter 2). This approach allows the *Guidelines* to account for important nonlinear behavior without requiring difficult and expensive modeling. Of course, a building-specific model that accounts for each non-conforming detail might offer a more accurate performance prediction, but it is impractical in many cases. The *Guidelines* are intended to represent an improvement over current code-based provisions and are expected to offer an appropriate balance of engineering rigor and cost-effective practice.

1.4 Purpose and Intended Use of the *Guidelines*

The *Guidelines* have a policy purpose as well as a technical objective. Current codes and standards for potential weak-story buildings are either overly simplistic, and therefore address only a narrow (and vague) range of mitigation goals, or are too comprehensive and complex to be used effectively on a large-scale program. By providing an alternative or complement to current codes and standards, the *Guidelines* are intended to make a range of mitigation programs more feasible and adaptable to a jurisdiction's needs.

Earthquake risk mitigation can be voluntary, mandatory, or triggered. Larger programs often involve linked but separable phases for evaluation and retrofit. As discussed, the most common engineering criteria for multi-unit wood-frame residential buildings are those in IEBC Chapter A4, but they focus on retrofit (not evaluation) and, because they are code-based, they are most suited to triggered projects where compliance with a pre-set standard is

the main objective. Meanwhile, it is not clear that the more generic and comprehensive standards, ASCE/SEI 31 and ASCE/SEI 41, would support cost-effective mitigation of a specific building type with a dominant deficiency.

Thus, the *Guidelines* offer potential benefits for a range of retrofit projects and programs:

- For voluntary retrofit, the *Guidelines* provide an alternative that can be applied with other codes and material standards much like IEBC Chapter A4. Where voluntary work is done to qualify for an incentive, the *Guidelines* provide clear metrics to gauge acceptability. Where the work is not targeted toward a minimum qualifying level, the *Guidelines* allow an owner and engineer to assess the existing condition in quantitative terms and to study the costs and benefits of various alternatives.
- For code-triggered work, the *Guidelines* provide alternative criteria that a jurisdiction can accept at its discretion. (See Section 2.3.3.)
- Mandatory programs are likely to benefit most from the *Guidelines*. The *Guidelines* are suitable for phased programs in which evaluations and retrofits might be scheduled or prioritized differently, or even keyed to different objectives. They also make possible a mitigation program with a tailored objective. Because the *Guidelines* are based on probabilistic fragility data, and not on pass-fail design criteria, they can also be used to support planning and policy studies in ways that current codes and standards cannot.

1.4.1 Policy Options

An important feature of the *Guidelines* is that they are adaptable. However, this means that an owner or jurisdiction must make some decisions in order to use them effectively. The main decisions involve the three components of the performance objective (see Section 2.3 for additional discussion): (1) the earthquake hazard of interest, (2) the desired performance level, and (3) the allowed probability of failing the objective. A unique feature of the *Guidelines* is that they acknowledge the benefit, as well as the liability, of sometimes not achieving the targeted performance objective in favor of more feasible first-story-only retrofits, which are referred to herein as “optimized” retrofits. Therefore, the owner or jurisdiction must also decide whether, and to what degree, to take the innovative approach of the *Guidelines*.

Table 1-1 lists the issues that require user input, together with options either recommended by or embedded in the *Guidelines*.

Table 1-1 Embedded and Alternative Criteria in the *Guidelines*

Issue	Criteria Embedded in the <i>Guidelines</i>	Alternative Criteria Options
Hazard Level	Maximum Considered Earthquake (MCE) (Section 5.4)	Any hazard level may be used (Section 5.4.1). While the MCE is the <i>theoretical</i> basis for code-designed new buildings, engineering criteria often use 2/3 (MCE) or a probabilistically defined hazard.
Performance Level	Onset of Strength Loss (OSL) drift levels (Sections 2.3.2 and A2.5)	Onset of Damage (OD) drift levels (Chapter 7). The OD drift levels correspond to less damage than the OSL levels.
Targeted Drift Limit Probability of Exceedance (<i>POE</i>)	User may select any value (Section 5.3).	20 percent is recommended if the objective is to be consistent with other codes and standards that use relaxed or reduced criteria for existing buildings (Sections 1.4.2 and 2.3.3).
Allowance of Optimized Retrofit	Recommended for many projects and programs (Section 6.4.2).	Optimized retrofit might not be suitable where high performance or strict compliance with other codes or standards is necessary (Section 6.2.3).
Maximum Acceptable Drift Limit <i>POE</i> for Optimized Retrofits	User may select any value greater or equal to the targeted drift limit <i>POE</i> .	Assuming optimized retrofit is allowed, the maximum acceptable <i>POE</i> should depend on multiple factors. However, where a <i>POE</i> less than 50 percent cannot be achieved, it suggests a very weak building that might warrant study outside the scope of the <i>Guidelines</i> (Section 6.4.2).

1.4.2 Selecting Performance Objectives

As suggested in Table 1-1, a common performance objective might call for a building to exceed the “onset of strength loss” drift limit in the Maximum Considered Earthquake (MCE) with a probability of no more than 20 percent. One or more of these choices can be altered to define a different objective. For example, a less aggressive, more lenient objective, which would find more existing buildings acceptable, could be obtained by choosing an earthquake hazard smaller than the MCE, or a drift limit probability of exceedance (*POE*) greater than 20 percent. An objective such as “reaching onset of strength loss in the MCE event, allowing for a 50 percent drift limit probability of exceedance” would be easier to achieve than the similar objective with a 20 percent targeted drift limit *POE*. Such an objective might be useful for a program targeting only the “worst of the worst” buildings.

Model building codes for new construction are expected to result in buildings with a 10 percent probability of collapse, given the Maximum Considered Earthquake (Luco et al., 2007; FEMA, 2009). Many codes and standards set less aggressive criteria for existing buildings. IEBC Chapter A4, for example,

allows the use of a 75 percent factor on design loads. This factor can be considered roughly consistent with the use of a 20 percent probability of collapse, as opposed to the 10 percent probability of collapse expected of new buildings (see ASCE/SEI 41-13, in preparation).

The appropriate performance objective depends on what a project or program is trying to achieve, and possibly also on whether it is considering only a single building or a city- or region-wide building stock.

For voluntary work on a single building, an objective can be selected to suit goals related to insurance coverage, or feasible repair costs, or the owner's particular risk tolerance. Often, voluntary work is scoped to match a certain project budget, and whatever performance results from that work becomes the *de facto* performance objective. The *Guidelines'* use of a drift limit probability of exceedance (*POE*) as a variable, as well as the Chapter 7 procedure for alternative performance assessment, can now help the owner and design professional quantify the benefits of a retrofit scope selected in this way.

For an incentivized voluntary program intended to achieve certain benefits citywide, the objective is best set by following the thought process for a mandatory program, below.

For work triggered by the building code, it is important to match the code's implied objectives. See Section 2.3.3.

For a simple mandatory program with no quantitative goals, a jurisdiction could set almost any performance objective, including the *Guidelines'* embedded hazard level (MCE) and drift performance level (onset of strength loss) criteria with any reasonable drift limit *POE* value, and expect to improve performance of individual buildings and of the jurisdiction as a whole. The cumulative effect of the mandated work on individual buildings could be estimated using the *Guidelines* together with ground motion data from one or more planning scenarios to account for variations in shaking in different parts of the city. That is, the effect of an arbitrarily chosen performance objective can be measured, but it might not correspond to any pre-set policy goal.

For a more sophisticated mandatory program, the right performance objective is the one that achieves the overall quantitative program goals when applied to each individual building mandated by the program.

1.5 Validation

Three validation studies were performed to confirm the *Guidelines*' novel methodology. Starting from basic concepts, an in-depth analysis effort duplicated the method's derivation, building and analyzing a range of surrogate models and deriving equations for evaluation and retrofit design. This effort confirmed the findings and conclusions developed during the surrogate model analyses as well as the equations in Chapters 5 through 7.

Secondly, a practical validation enlisted engineers unfamiliar with the method and asked them to analyze and design retrofits for two actual buildings. The purpose of the study was partly to check the method's results for their practical meaning, but mostly to confirm that the new definitions, equations, and procedures could be followed and properly applied by engineers seeing them for the first time. This study led to several clarifications and small technical revisions.

Thirdly, example calculations were prepared (and included in these *Guidelines*) to illustrate some of the new concepts and engineering procedures.

1.6 The Weak-Story Tool

A Weak-Story Tool, similar to a graphical spreadsheet, was also developed as part of the project to help apply the rules and perform the calculations described in *Guidelines* Chapters 4 through 7. Guidance on the use of the Weak-Story Tool is provided in Appendix A.

By incorporating the tables of material properties and the rules for applying them, the Tool's initial benefit is simply to organize the user's work. Once building data is entered, however, the Tool facilitates modifications and presentation of results. It also makes comparative studies of different retrofit schemes easy. Still, as with any such tool, results should be verified by appropriate checks and quality control measures. Proper application of the Tool and understanding of its workings and its output remain the responsibility of the user.

The Weak-Story Tool is not needed to use the *Guidelines*. The text of the *Guidelines* contains all the data, formulas, and procedural background needed to apply the method without using the Tool.

1.7 Guidelines Organization and Content

These *Guidelines* are written and organized to serve as background, commentary, and technical content for future building codes and seismic

mitigation programs. The *Guidelines* present new engineering procedures in seven chapters that generally follow the sequence in which existing buildings would be evaluated and retrofitted. Appendices provide greater detail on specific topics of interest to certain user groups.

Chapter 1 provides non-technical background and describes the issues the *Guidelines* were developed to address. Since the *Guidelines* are adaptable, Chapter 1 also identifies the decisions that policy makers or mitigation planners will need to make when implementing the provisions, including the specification of a performance objective.

Chapter 2 provides a technical overview of the engineering procedures of the *Guidelines* and their analytical basis. It also gives the limitations and conditions a candidate building must meet to be eligible for these procedures.

Chapter 3 is the first of five technical chapters. As an abbreviated version of Chapters 4 and 5, it provides a simplified (and generally conservative) method for determining the capacity of a candidate building.

Chapter 4 gives the definitions and rules for characterizing an existing building's strength, displacement capacity and toughness, and potential deficiencies. It provides new default material data for typical wall sheathing types. Chapter 4 concludes by defining several characteristic coefficients used in the full evaluation procedure of Chapter 5.

Chapter 5 provides the equations that define a building's capacity, given its characterization by Chapter 4. Chapters 4 and 5 apply to retrofitted buildings as well as existing buildings.

Chapter 6 describes the logic for selecting, bounding, and optimizing the appropriate retrofit strength for buildings found deficient relative to the performance objective. Chapter 6 recognizes that the best possible performance of a first-story retrofit might not achieve the targeted performance objective but might be cost-beneficial regardless.

Chapter 7 provides alternative versions of the Chapter 5 and 6 capacity equations for a higher performance level ("onset of damage" as opposed to "onset of strength loss").

Appendix A is a user's guide for the Weak-Story Tool described in Section 1.6.

Appendix B, intended for policy makers and code officials, discusses potential implementation of the *Guidelines* in mitigation programs, as well as a basis for setting performance goals. It also provides a code language

version of Chapters 4 through 6 to facilitate incorporation into building codes or regulations.

Appendix C, intended primarily for engineering practitioners and code officials, illustrates some of the new procedures with numerical calculations representative of an actual building.

Appendix D^{*} describes the testing data used to derive the *Guidelines*' criteria for characterizing the strength and ductility of sheathed wood-frame walls. It is intended primarily for engineering practitioners as background to the provisions in Chapter 4 and for researchers.

Appendix E^{*} provides a detailed technical explanation and derivation of the procedures in Chapters 3 through 7. It is intended for technical readers who want to understand the full engineering basis of the new procedures, including the fragility data from analyses of surrogate models.

Appendix F^{*} describes an independent validation study that confirmed the modeling and analysis presented in Appendix E. Like Appendix E, it is intended primarily for researchers and for reviewers of the new procedures.

^{*} Appendices D, E, and F are not included in the printed version of the *Guidelines*, but can be found on the CD that accompanies these *Guidelines*.

The principal features of the methodology, which distinguish it from other codes and standards, include the following:

- The methodology is statistical, not explicit. Once the structure is modeled, it is not analyzed directly. Rather, it is compared statistically with other similar structures already analyzed.
- Acceptability is based on drift, not on internal force or stress levels.
- Performance objectives explicitly include a targeted probability of exceedance relative to drift limits.
- Cost-effective retrofit schemes that keep work and disruption within the critical first story are emphasized, even if a targeted performance objective is not fully achieved.

This chapter presents an overview of the statistical basis of the underlying methodology (Section 2.1), an overview of the surrogate analyses that were conducted to form the technical basis for the methodology and the means for characterizing an existing building in terms related to the design space of the surrogate analysis models (Section 2.2), acceptability criteria and related performance objectives (Section 2.3), a description of the critical deficiencies in buildings of the type considered by the *Guidelines* (Section 2.4), an overview of the cost-effective retrofit design philosophy incorporated in these *Guidelines* (Section 2.5), and *Guidelines* limitations and building eligibility requirements (Section 2.6).

Chapters 3 through 7 of the *Guidelines* present the details of the prescriptive methodology for modeling and evaluating existing structures, sizing retrofit elements, and quantifying the benefits of retrofit in probabilistic terms. The formulas and criteria in those chapters are premised on certain presumptions and limitations, discussed in this chapter.

Figure 2-1 broadly illustrates the *Guidelines* content and expected application from the perspective of the engineer user. More detailed flowcharts for each broad step are given with the referenced chapters.

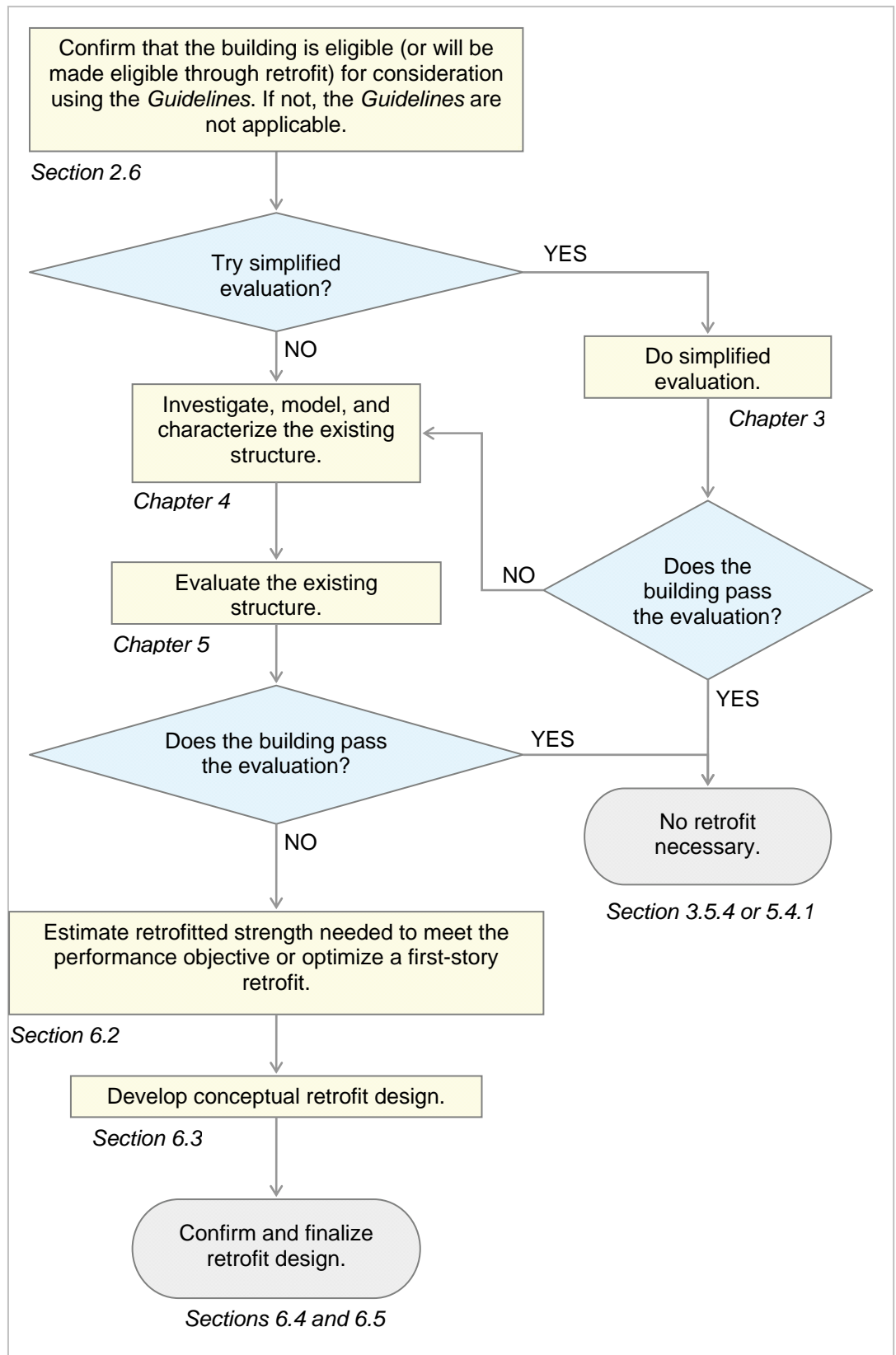

Figure 2-1 Flow chart illustrating relationships between the *Guidelines* technical chapters.

2.1 Statistical Basis

Unlike most evaluation and design methodologies, the *Guidelines* do not rely on an explicit structural analysis of the building in question. That is, they do not require the creation of a unique structural model, the application of loads to that model, or the calculation of reactions, deflections, or internal member forces. Instead, the structure in question is compared with hundreds of hypothetical similar structures, or surrogate models, each of which has already been assessed with nonlinear response history analysis. The comparison is made on the basis of a few key parameters, with regression formulas that represent the aggregate fragility of the surrogates. The characterization of the actual building strength and deformations is necessary for this comparison. A full description of the statistical basis and the development of fragility curves and regression formulas is provided in Appendix E.

The reason for this statistical approach is to relieve the engineer (and owner) of burdensome (and costly) nonlinear analysis. Certainly it is possible to evaluate a wood-frame structure and to design its retrofit with explicit structural analysis, but it is also more difficult. As noted in Chapter 1, ease of evaluation and design is part of the cost-effectiveness intended by the *Guidelines*. To the extent that the statistical approach reliably captures the significant aspects of any eligible building, it offers a valuable alternative to traditional analysis.

2.2 Modeling Actual and Surrogate Structures

2.2.1 The Surrogate Models

The fragility data against which a particular building is compared was derived from analyses of hundreds of surrogate models, described in detail in Appendix E. The surrogate models represent a wide design space that accounts for realistic variations of material ductility, first-story strength, ratio of first-story strength to upper-story strength, and other variables.

The types of actual wood-frame buildings covered by the *Guidelines* generally have obsolete or non-conforming conditions in addition to an open front or potentially weak story. For example, most walls in actual buildings lack the overturning restraint that would come from hold-downs or story-to-story ties. Also, existing buildings might have inadequate collectors, diaphragms, or other load path elements. The surrogate analyses did not explicitly model these load path gaps.

The surrogate models did not account for interaction with adjacent buildings (also called pounding), which can occur where large buildings are divided in plan by narrow seismic joints or where dense development patterns required essentially no gaps between buildings (as in parts of San Francisco). Recent work with 1920s-era buildings has suggested that weak-story structures at the end of a block might have a slightly increased fragility if subject to pounding, but that retrofit mitigates that effect (Maison et al., 2011). Similar studies with smaller buildings subject to pounding on two sides is ongoing, but in any case, the effects are not expected to be significant with respect to the *Guidelines* methodology.

The key performance measure for the surrogate models is peak transient interstory drift—the maximum lateral deformation within a story over a full response history, divided by the story height. Two drift limits are used: 1.25 percent for stories with only low-displacement capacity elements (with an assumed strength degradation ratio, C_D , of 0.0; see Sections 4.4 and 4.7.4), and 4.0 percent for stories with high-displacement capacity elements ($C_D = 1.0$).

The *Guidelines* focus primarily on extreme performance levels under severe loads. The two drift limits, however, are not associated explicitly with collapse because there is not a robust historical record relating collapse to predicted drift. Rather, the drift limits are derived from tests of various sheathing materials and represent the onset of strength loss, an element-specific condition assumed to indicate a substantially increased potential for collapse.

Figure 2-2 illustrates the two material models used in the surrogate structures. The use of two drift limits follows precedents in other codes and standards for existing buildings, such as ASCE/SEI 41 (ASCE, 2006b), which distinguishes between force-controlled and deformation-controlled elements and sets acceptability limits element by element.

All stories are considered in checking the surrogate model drifts. For example, if a model has only low-displacement capacity elements, such as stucco, throughout its height, it is considered to have “failed” the fragility criteria if any story exceeds the 1.25 percent limit during a response history. If the same model is retrofitted with high-displacement capacity elements in the first story, such as wood structural panels, then it fails the criteria if *either* the first-story drift exceeds 4.0 percent *or* any upper story drift exceeds 1.25 percent. (See Appendix E for further details.)

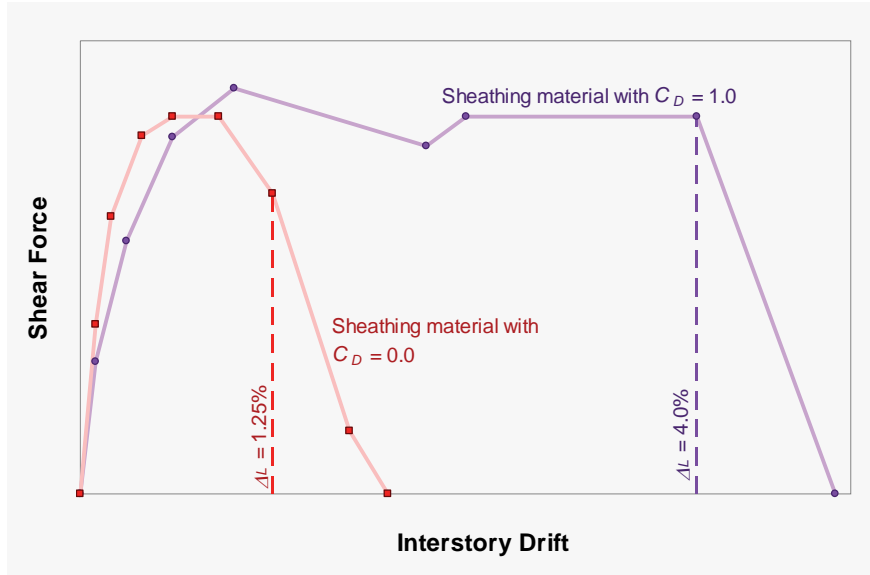

Figure 2-2 Plots of interstory drift versus shear force showing drift limits, Δ_L , used to develop fragility relationships from the surrogate models. Sheathing materials with strength degradation ratio, $C_D = 1$, have high-displacement capacity, and those with $C_D = 0$, have low-displacement capacity.

2.2.2 Characterizing an Existing Building

The surrogate models cover a wide range of material properties, story strengths, and other variables (collectively referred to as the “surrogate space”). When working with an actual specific building, however, it is important to characterize it accurately enough that its capacity can be estimated and located within the surrogate space.

Like other codes and standards for existing buildings, the *Guidelines* assign strength and stiffness even to wall segments constructed with archaic materials and detailing. For new construction, such “non-conforming” elements would be designated as non-structural partitions and would not be allowed to count toward required strength. For potential weak-story structures, however, this practice can significantly underestimate story strength and lead to unconservative conclusions. Upper stories, with many interconnected walls and partitions, are often reasonably strong.

The *Guidelines* therefore rely on realistic estimates of material strength and corresponding deformation. Chapter 4 gives default strength values for non-conforming sheathing materials over a range of story drifts. The strength values were derived from wall component tests, as documented in Appendix D. The *Guidelines* use “strength” to mean a complete load-drift relationship, not just a single peak value. Chapter 4 gives procedures for characterizing

and combining materials, wall assemblies, wall lines, and stories in a way that considers displacement capacity.

To account for load path and configuration details, the *Guidelines* apply a series of factors to the estimated story strength. As described in Chapter 4, the *Guidelines* modify the story strength, and eventually the structure's overall capacity, with factors that account for wall and story height, wall overturning and uplift, wall openings, and wall configuration as it affects torsional response.

The *Guidelines* assume that story shear can induce torsion even with wood floor diaphragms and that the torsion will be resisted by walls with any orientation, as if the diaphragm were essentially rigid. While this is not traditional practice for wood diaphragms, it is consistent with the ASCE/SEI 7 default requirement for new structures, and the *Guidelines*' writers consider it a more realistic description of actual performance. Limitations on diaphragm span and configuration are expected to rule out extreme cases where this assumption would not hold.

2.3 Acceptability Criteria

2.3.1 Performance Measure

As shown in Chapter 5, the *Guidelines* gauge the acceptability of a structure by calculating its capacity in terms of spectral acceleration, then comparing that capacity to a site-specific spectral acceleration demand. The capacity, however, is derived from fragility data that relate ground motion to interstory drift (see Appendix E).

As described above, the intent of the *Guidelines* is to base acceptability on a severe condition such as near-collapse. Chapter 7 provides guidelines for adjusting the methodology for different drift limits.

2.3.2 Performance Objective

As in other performance-based standards, the *Guidelines* use a performance objective that combines a desired performance level with a presumed hazard level. The *Guidelines*' default (embedded) performance objective may be stated as: "A given probability of not exceeding the drift limits associated with onset of strength loss, in a Maximum Considered Earthquake."

The *Guidelines* also allow users to select a targeted maximum probability of exceeding the drift limits, or, put another way, a confidence level for meeting the objective. Thus, if a 20-percent drift limit probability of exceedance (*POE*) is selected, a complete statement of the default performance objective

would be: “80-percent confidence of not exceeding the drift limits associated with onset of strength loss, in a Maximum Considered Earthquake.” The *Guidelines* allow the user to set all three parts of the performance objective, to varying degrees:

- The drift limit *POE* is selected and applied as part of the evaluation process, in Section 5.3.
- Two performance levels are available. Drift limits for “onset of strength loss” are embedded in the evaluation and retrofit procedures in Chapters 5 and 6 as the default. Chapter 7 provides alternative parameters with which to adjust the evaluation and retrofit equations for drift limits at the “onset of damage.”
- Any demand level may be used. Chapter 5 presents evaluation criteria using the Maximum Considered Earthquake hazard defined in ASCE/SEI 7-05 (ASCE, 2006a) as the default (embedded criteria), but the short-period spectral acceleration value from any hazard can be substituted to represent a different performance objective.

2.3.3 Relationship to Other Codes and Standards

With a drift limit probability of exceedance (*POE*) of 20 percent, the *Guidelines* default objective is expected to be similar to an ASCE/SEI 41 (ASCE, 2006b) objective of “Collapse Prevention in a BSE-2¹ event.” No correlation or performance equivalence studies between the *Guidelines* and “Collapse Prevention in a BSE-2 event,” however, have been made as part of the effort to develop these *Guidelines*.

Currently, the technical criteria most commonly used for retrofit of weak-story wood-frame buildings are from Chapter A4 of the *International Existing Building Code* (ICC, 2009b). IEBC Chapter A4 does not state a performance objective. It relies on definitions of weak-story and soft-story irregularities from ASCE/SEI 7-05 and the code for new construction, so it is unclear how the *Guidelines* compare, especially with respect to evaluation (which is not Chapter A4’s primary focus). Table 2-1 compares the *Guidelines* with Chapter A4 on issues related to performance expectations for *Guidelines*-eligible buildings.

While the *Guidelines* can be nominally aligned with Chapter A4 (or any other code or standard) by selecting the right drift limit *POE*, performance

¹ BSE-2 denotes Basic Safety Earthquake level 2, an earthquake hazard level with ground motions have a 2% probability of being exceeded in 50 years.

Table 2-1 Comparison of the *Guidelines* to 2009 IEBC Chapter A4

Issue	Guidelines	2009 IEBC Chapter A4
Drift Limit Probability of Exceedance	At user’s discretion. 20 percent is recommended for comparison with code-based criteria for existing buildings. Full compliance may be waived to accommodate first-story-only retrofit.	For evaluation: Not applicable. For retrofit: None stated, but 75 percent factor is applied to code-level earthquake hazard.
Performance Level for Evaluation	Onset of Strength Loss or Onset of Damage	Code-based definitions of weak story, soft story, and open front. No performance-based criteria.
Performance Level for Retrofit	Onset of Strength Loss or Onset of Damage	Code-level performance (with some exceptions), based on drifts and material strengths allowed for new construction. Upper stories not considered.
Earthquake Hazard	At user’s discretion. Maximum Considered Earthquake per ASCE/SEI 7-05 is recommended for collapse- or safety-based objectives.	Code-level design basis earthquake: 2/3 of the Maximum Considered Earthquake per ASCE/SEI 7-05.
Existing material and system characterization	Peak strength and load-drift curves given. No resistance factors applied.	None specified. Code-based standards for new construction apply by reference.
Retrofit material and system characterization	Retrofit elements must have high-displacement capacity. Some systems disallowed. Allowed systems may be combined.	No limits on systems, except for code-based rules on combining systems.
Retrofit scope	First story only, plus load path from second-floor diaphragm to soil. Retrofit calibrated to prevent upper-story failure.	First story only, plus load path from second-floor diaphragm to soil. No check on upper-story performance.

level, and hazard, the task is not straightforward. With respect to Chapter A4, Table 2-1 allows some observations on this point:

- Chapter A4 uses “reduced” seismic loads (75 percent of those used for new buildings). Similarly, the *Guidelines*, with a 20 percent drift limit *POE*, allow a higher probability of exceedance than is expected of new construction (see Section 5.3, citing Luco, et al., 2007).
- Assuming a 20 percent drift limit *POE* and the default objective of onset of strength loss in MCE-level shaking, the *Guidelines* appear to be more conservative than Chapter A4 regarding the hazard, but less conservative regarding the characterization of existing and retrofit elements.
- Chapter A4 requires lateral-system improvements only in the critical first story. Similarly, the *Guidelines* stipulate cost-effective first-story retrofits, and even recommend waiving the targeted performance objective in favor of project feasibility. Importantly, however, the *Guidelines* are careful to check that strengthening the first story does not

push the failure into the upper stories. Chapter A4 does not make this check.

2.4 Critical Deficiencies

The *Guidelines* are not a comprehensive code or standard for generalized seismic evaluation and retrofit design. Rather, they focus on a few characteristic deficiencies understood to be most responsible for unacceptable past performance of a certain building type. The premise of the *Guidelines* is that traditional or vernacular designs with relatively open first stories gave rise to buildings with inadequate strength and resistance to collapse. These buildings' weak first-story deficiencies, often exacerbated by torsion, are the primary focus of the *Guidelines*, but building performance as a whole is also addressed.

Seismic deformation concentrates in a weak first story. While the first story undergoes large deformations, the upper stories tend to respond as a stiff block over a weak and deformable base. This weak-story mode dominates the dynamic response, both in the elastic range, but especially in the inelastic range, where concentrated damage can lead to collapse.

Figure 2-3 shows the differences in wall layout and density between first and upper stories in three representative buildings. In the figure, the top and bottom buildings are characteristic of dense urban development with access to first floor parking directly from the street. The top building is a midblock configuration (typical of Victorian- or Edwardian-era buildings in San Francisco) with garage access at one end only, ample longitudinal walls, and light wells that lead to a barbell-shaped diaphragm. The bottom building is a corner configuration (typical of 1920s-era San Francisco apartment houses) with garage doors along both street-facing sides. The middle building in Figure 2-3 is a more modern prototype (typical of 1960s buildings throughout the San Francisco Bay Area, Greater Los Angeles, and the Pacific Northwest). While its massing and block location are similar to the top building, it has a drive aisle along the side, leading to a wide-open tuck-under parking area.

While all three buildings in Figure 2-3 have likely weak stories, the designs vary with a building's location within a block and the nature of its street or sidewalk access. Different weak-story designs thus have different torsional sensitivities. Figures 2-4 and 2-5 illustrate how torsion can exacerbate the weak-story deficiency. The arrows show the center-of-strength² locations of

² Center of strength is defined as the location of the force resultant of the wall strengths (see Section 3.4.4 for additional information).

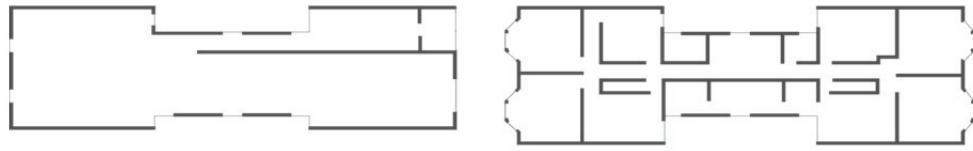

Mid-Block Building: Weak with minor torsion



Open Front, Tuck-under Building: Weak with torsion due to earthquake loads in the long direction

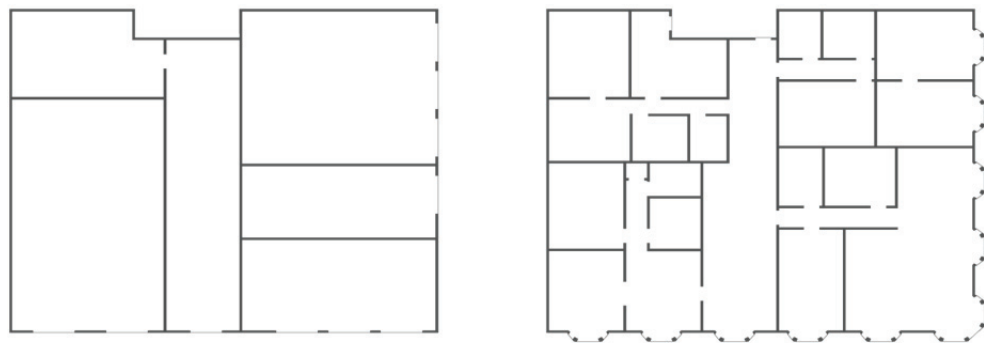

Corner Building: Weak with bi-directional torsion due to earthquake loads in either direction

Figure 2-3 Plan diagrams of three weak-story buildings. Left: first story. Right: upper stories.

the first and upper stories, respectively. The distance between them indicates the eccentricity that gives rise to torsion in the first story. Figures 2-4 and 2-5 also illustrate the difference between one-directional torsion and bi-directional torsion.

2.5 Retrofit Design Philosophy

2.5.1 Cost-Effective, First-Story Retrofit

Fundamental to these *Guidelines* is the stipulation that retrofit work should be kept to the first story. This constraint follows from an understanding of the building type in question. The *Guidelines* have in mind a building with (or without) a dominant deficiency in the first story and an occupied status that makes retrofit work in the upper stories disruptive and expensive.

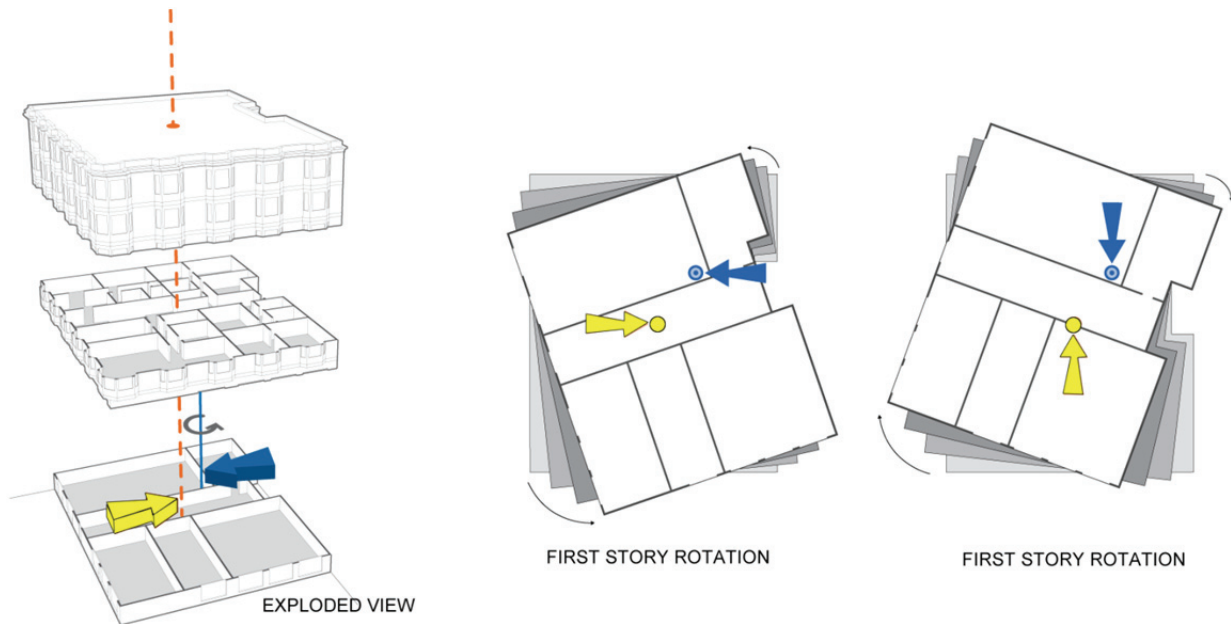

Figure 2-4 Schematic response of a corner building subject to torsion under loads in either direction, due to open wall lines on two sides at the first story. The distance between the arrows indicates the eccentricity that gives rise to torsion in the first story. The light arrow denotes the center of strength of upper stories; the dark arrow denotes the center of strength of the first story.

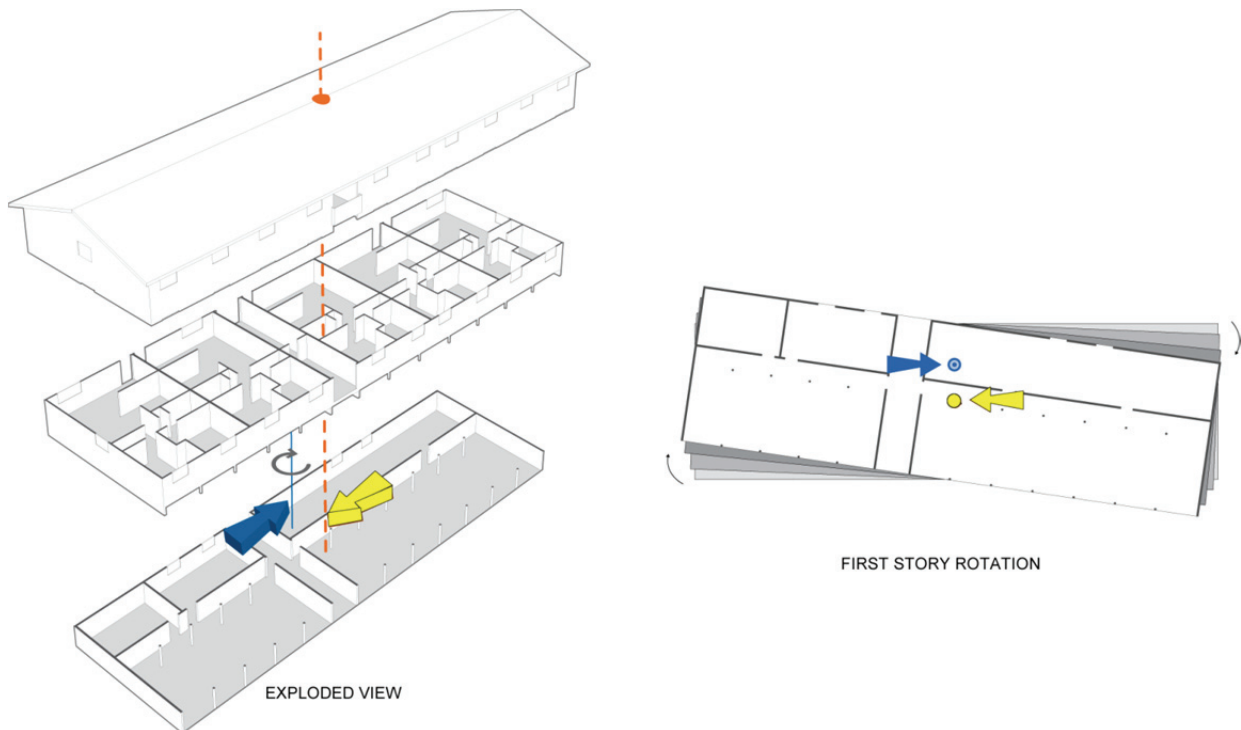

Figure 2-5 Schematic response of a building with a slightly weak story in the long direction and with torsion under loads in the long direction. The distance between the arrows indicates the eccentricity that gives rise to torsion in the first story. The light arrow denotes the center of strength of upper stories; the dark arrow denotes the center of strength of the first story.

Limiting retrofit to the first story recognizes the need, discussed in Chapter 1, to provide adequate benefit for minimal cost. This means that a retrofit in accordance with the *Guidelines* might knowingly leave less dominant upper-story deficiencies in place while limiting the displacement demand they experience. Such a retrofit might not achieve the same performance as a comprehensive top-to-bottom upgrade and might not satisfy the letter of other applicable codes or standards, something that needs to be approved by the authority having jurisdiction. Nevertheless, this is a tradeoff that may sometimes be found to be in the interest of owners, tenants, and jurisdictions because it allows the work to be done while the building is occupied.

2.5.2 Bounded Design and Relative Strength

For most weak-story buildings, a first-story retrofit is expected to address what is by far the structure's weakest link. Upper stories might have unaddressed deficiencies, but as long as they are not made worse, the first-story retrofit improves the building's overall seismic performance in a cost-effective way.

But what if the first-story retrofit *does* make upper stories more vulnerable? This is possible because the weak first story, by absorbing all the lateral deformation, protects the upper stories. When the weak story is strengthened, the structure becomes more regular, with deformations no longer concentrated in one story. So when the first story is strengthened, upper stories will have to sustain higher forces and drifts.

Figure 2-6 illustrates this effect. The different lines represent similar four-story structures with different first-story strengths. In the existing structure, the first-story drift far exceeds even a 4-percent limit, while corresponding drifts in the upper stories are small. As the first story is made stronger, the first-story drift decreases, but corresponding upper-story drifts increase. Eventually, the second-story drift exceeds its limit of 1.25 percent; this is the unintended consequence of an overly strong retrofit.

The acceptable retrofits are those that reduce the first-story drift enough to satisfy the 4-percent drift limit (a high-displacement capacity) but keep the upper stories under their 1.25-percent limit (assuming the upper stories have low-displacement capacity). The least-cost retrofit is the acceptable retrofit that satisfies both criteria by adding the least amount of material to the first story. The best-performance retrofit is the one that reduces the first-story drift the most, while keeping upper stories within their drift limits.

Chapter 6 provisions give the retrofit strength corresponding to these two bounding cases. The first bound—the minimum required strength of the

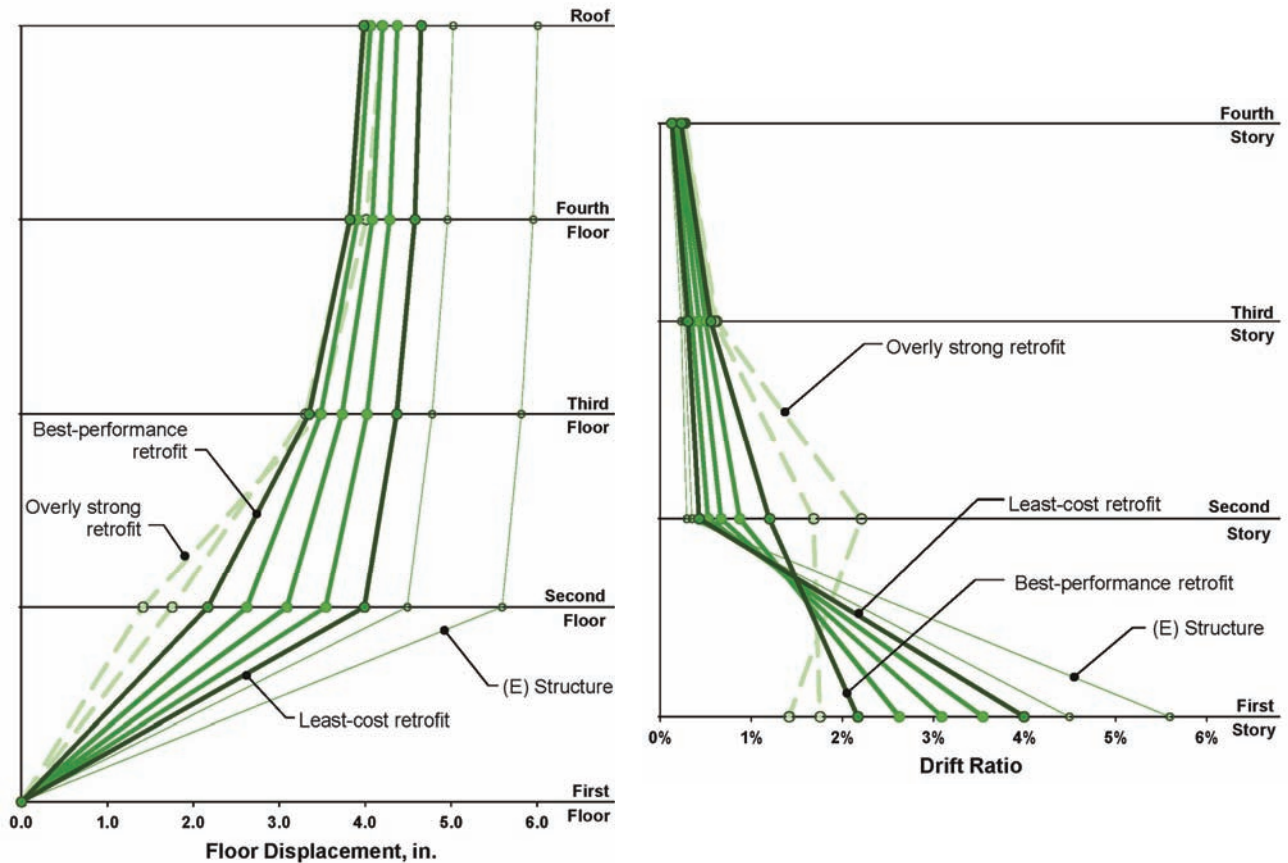

Figure 2-6 Plots illustrating floor displacements and drift ratios in a building with constant upper-story strength and varying first-story strength. (E) Structure = Existing Structure.

retrofitted first story—is that required to reduce the first-story drift to an acceptable level. The second bound—the maximum acceptable strength of the retrofitted first story—essentially sets a limit on the relative strength of the first and second stories.

In certain buildings, the overall structure may be so weak that the two bounds will be in conflict, and it will be impossible to satisfy both conditions with a first-story-only solution. In these cases, the upper bound, based on the relative strength of the first and second story, is used to control the design. This cap on relative strength is a key feature of the *Guidelines* methodology.

2.6 Limitations and Eligibility Requirements

Because the *Guidelines* are based on statistical data and do not require customized modeling and analysis of a particular building, they only apply reliably to the range of conditions considered in developing the fragility relationships. For most of the limitations described below, eligibility is restricted only because the ineligible condition was not explicitly studied, not because the methodology has been shown not to work.

Buildings eligible for evaluation or retrofit using the *Guidelines* satisfy all of the following conditions. A building may be altered in accordance with Chapter 6 to make the building eligible. Unless noted otherwise, the same rules apply to both an existing building being evaluated and to the retrofitted building being designed or checked.

2.6.1 General Eligibility Requirements

- The building has no more than four wood-frame above-grade stories or partially above-grade stories.
- The building does not have an above-grade concrete (or similarly stiff) podium structure (e.g., concrete-wall structure) supporting the wood-frame stories.
- There is no restriction on soil type or site class. However, it is important to note that the surrogate analyses on which the methodology is based used the ground motions considered in the development of the FEMA P-695 Report, *Quantification of Building Seismic Performance Factors* (FEMA, 2009), which considered ground motion records from site classes C and D, but not site classes B, E, or F. To the extent that soft soil records would have significantly changed the response of the surrogate models, use of the *Guidelines* for such sites could be unconservative. Even so, it is the judgment of the *Guidelines*' writers that code-prescribed site coefficients (F_a), if applied when selecting the spectral acceleration demand used to check the building in Chapter 5, are sufficient to account for soil effects. The selection of F_a to adjust for site class effects, rather than F_v , is because F_a provides the most consistent and straightforward basis for comparing the actual building to the surrogate analyses. (See Appendix E for details on the surrogate analyses.)

2.6.2 Upper-Story Eligibility Requirements

- The primary components of the upper-story seismic-force-resisting system are wood-frame stud walls.
- The upper-story heights (floor-to-floor) are between 8 feet and 12 feet, and the height of any upper story is constant within that story.
- No upper story is prone to significant torsion. The methodology assumes that inertial forces from upper stories transfer to the first story near the geometric center of the second floor. As an approximate rule, this assumption may be considered satisfied if in each upper story, the distance from the story's center of strength (see Section 4.6.4) to the

center of mass of the floor below it is no more than 25 percent of the corresponding building dimension, as illustrated in Figure 2-7.

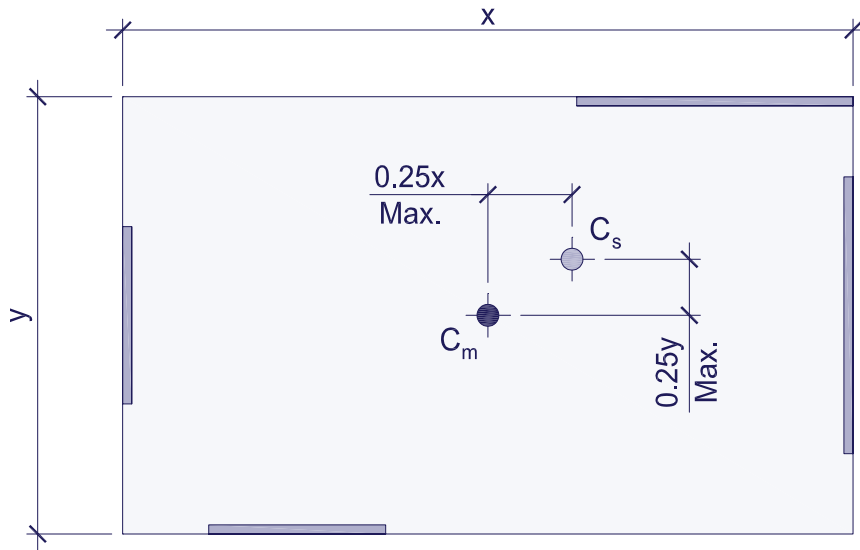

Figure 2-7 Floor plan schematic showing limits on eccentricity between the center of strength (C_s) of each upper story and the center of mass (C_m) of the floor below it.

2.6.3 First-Story, Basement, and Foundation Eligibility Requirements

- The upper stories have no vertical mass or geometric irregularities as defined by ASCE/SEI 7-05 Table 12.3-2 (Irregularity Types 2 and 3).
- The maximum first-story height (top of foundation to top of second floor) is between 8 feet and 15 feet. The first-story height may vary within the story.
- The primary components of the first-story seismic force-resisting system are wood-frame stud walls or combine wood-frame walls with steel moment frames.
- The first-story walls have continuous concrete or masonry perimeter foundations, or concrete slab-on-grade foundations.
- If the wood-frame walls and steel frames are partial-height over stiff (concrete or masonry) retaining walls or foundation stem walls, the wood-frame or steel portion is at least four feet tall (top of stem wall to underside of second floor framing).
- The first-story seismic force-resisting system does not include any full-height concrete or masonry walls.
- If the building has a basement below the first story, the basement walls and the floor diaphragm just above them are capable of transferring

seismic forces between the foundation and the first wood-frame story. The basement story is laterally stronger than the first story above it.

- If the first floor is partly slab-on-grade and partly raised over a crawl space, the crawl space has concrete stem walls to the underside of the framing and does not have wood cripple walls (braced or unbraced).

2.6.4 Floor and Roof Diaphragm Eligibility Requirements

The *Guidelines* methodology was developed by studying structures dominated by weak-story deficiencies. The effects of significant diaphragm or load path deficiencies were not explicitly considered. As a general rule, then, any structure in which a diaphragm or load-path deficiency would control the response should not be eligible for the *Guidelines* without either separate careful study or remediation. The rules below, while rational and appropriate, were not derived from the surrogate analyses. Therefore, while the quantitative limits reflect the judgment of the *Guidelines*' writers, they should also be considered open to modification, and subject to the reasoned judgment of the engineer and building official.

As noted above, an ineligible building may be made eligible through alteration or retrofit. That is, if the alteration would correct the deficiency, the building may be assumed eligible for purposes of applying the *Guidelines*, with the understanding that the correction will be implemented even if the existing building, treated as eligible, already satisfies the performance objective.

An ineligible diaphragm can often be made (or considered) eligible if it can be broken (figuratively) into a series of eligible sections divided by qualifying walls or frames. In order to qualify to divide a diaphragm for this purpose, a wall or frame line must contribute significantly to the peak first-story strength in the direction of interest. There is no analysis-based rule for what it means to "contribute significantly," but the concept is that a nominal length of wall that would otherwise not be considered an important part of the seismic force-resisting system probably should not qualify to help make the diaphragm perform more regularly. As an approximate rule, any wall line contributing, say, at least half as much strength as the strongest parallel wall line may be considered as qualifying. In any case, some judgment is appropriate here, and any qualifying wall line should be confirmed as capable of delivering its assumed properties.

With this understanding, the recommended eligibility rules for diaphragms are as follows:

- The second floor diaphragm has an aspect ratio not greater than 2:1. Diaphragms with larger aspect ratios are eligible if each section of the diaphragm between qualifying wall lines has an aspect ratio not greater than 2:1. See Figure 2-8.

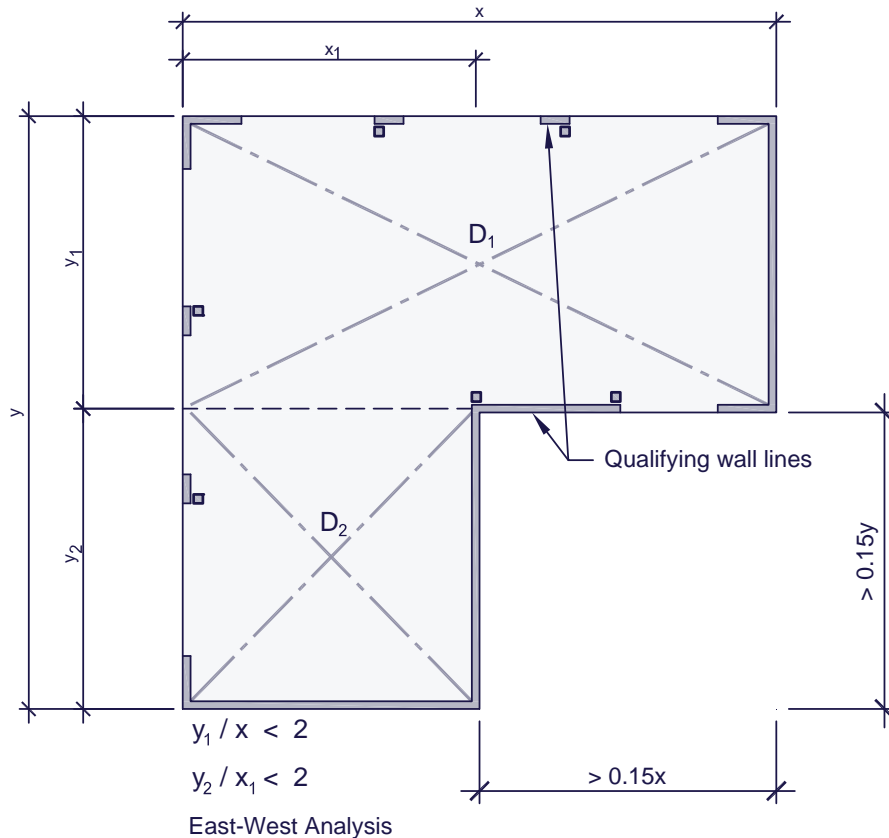

Figure 2-8 Floor plan schematic showing use of qualifying wall lines to meet diaphragm aspect ratio limits. D denotes diaphragm.

- The second floor diaphragm does not cantilever more than 25 feet from a qualifying wall line.
- If the second floor diaphragm has a cantilevered span greater than 10 feet, diaphragm chords are adequate to develop the lesser of the strength of the diaphragm or the diaphragm forces associated with the peak strength of the qualifying “supporting” wall line. See Figure 2-9.
- No floor or roof diaphragm has a reentrant corner irregularity, defined as a condition in which both plan projections beyond a reentrant corner are longer than 15 percent of the plan dimension of the structure in the corresponding direction, except that diaphragms with reentrant corners are eligible if each leg of the diaphragm satisfies the aspect ratio and cantilever rules above. See Figure 2-10. The eligibility rules for buildings with reentrant corners might be more conservative than the

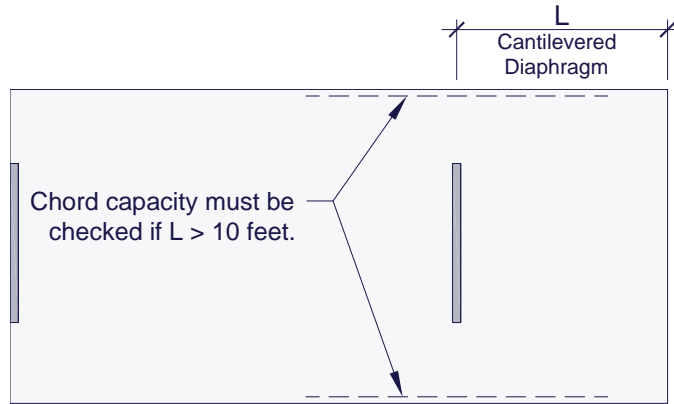

Figure 2-9 Floor plan schematic showing locations of chords for cantilevered diaphragms that must satisfy eligibility rules.

requirements of ASCE/SEI 31, which in some cases do not identify reentrant corners as problematic in seismic performance. The eligibility requirements are included to ensure that diaphragm demands are limited.

- No floor or roof diaphragm has a vertical offset (a stepped or split level, for example), unless load path components are present and adequate to develop the diaphragm strength across the offset.

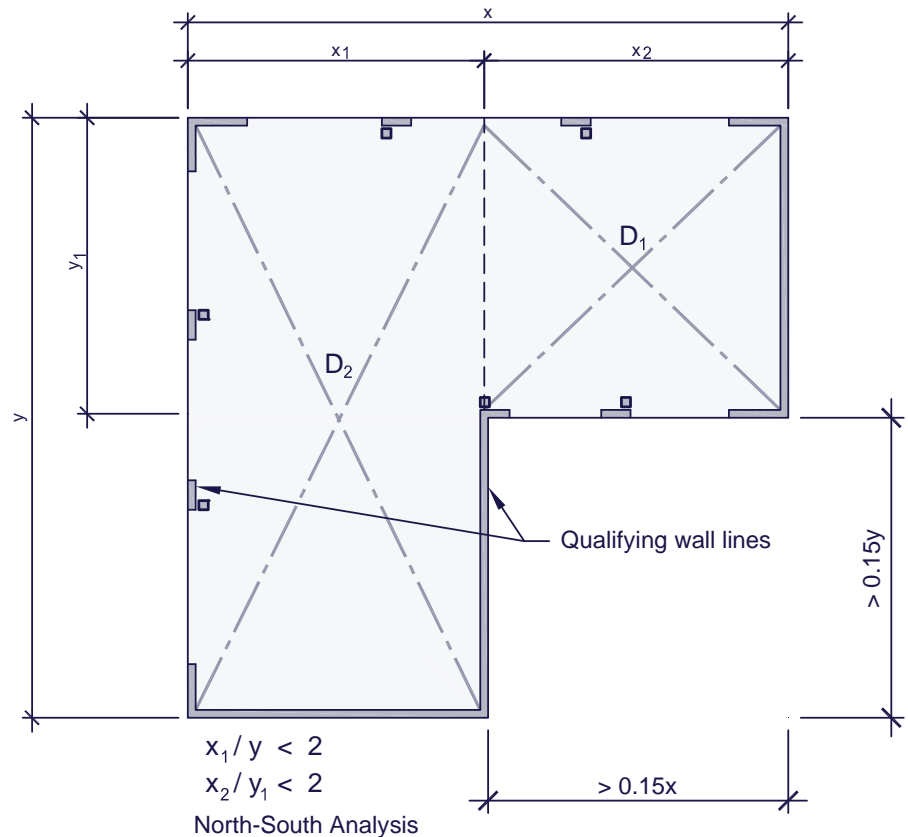

Figure 2-10 Floor plan schematic showing reentrant corner limits and use of qualifying wall lines to satisfy eligibility rules. D denotes diaphragm.

- No floor or roof diaphragm has excessive cutouts or openings within it. Excessive openings are deemed to exist if, along any line across the diaphragm, the sum of the opening widths along that line is more than 25 percent of the overall diaphragm dimension along that line. See Figure 2-11.

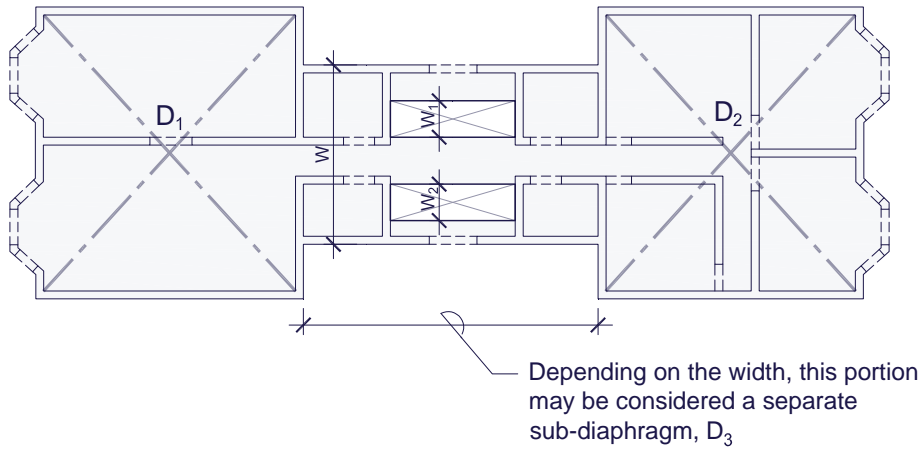

Figure 2-11 Floor plan schematic showing diaphragm openings that must be limited in size to satisfy eligibility requirements. D denotes diaphragm.

Chapter 3

Simplified Evaluation

3.1 Purpose

This chapter provides a simplified evaluation procedure that requires less building surveying and less computation than the full evaluation procedure of Chapters 4 and 5. Certain assumptions and simplifications make the simplified procedure somewhat more conservative but less time-consuming.

Chapter 3 will be clearly advantageous when the building would likely meet the performance objective if it were to be evaluated using Chapters 4 and 5. The conditions where this would be the case would include some combinations of:

- The existing building has wood structural panel sheathing as its primary later-force-resisting system,
- The targeted drift limit probability of existence (*POE*) is 20%, and
- The site is located in a region of moderate or low seismicity.

3.1.1 Limitations

This procedure only applies if:

- The upper-story strengths are clearly stronger than the first-story strength,
- The building meets the eligibility rules of Section 2.6, and
- The selected performance level involves drift limits associated with onset of strength.

3.2 Simplified Evaluation Procedure

The simplified evaluation procedure comprises the following steps:

1. Perform a detailed survey of the first story and a cursory survey of the upper stories in accordance with Section 3.3.
2. Compute characterizing coefficients in accordance with Section 3.4.
3. Select a targeted drift limit probability of exceedance for the building and determine the drift limit probability of exceedance (*POE*) adjustment factor using Table 3-1, which provides *POE* adjustment factors for low-

Table 3-1 Drift Limit Probability of Exceedance (POE) Adjustment Factors for Low-Displacement Capacity Elements

Targeted Drift Limit Probability of Exceedance (POE)	Adjustment Factor for Low-Displacement Capacity Elements*, $\alpha_{POE,0}$
2%	0.29
5%	0.37
10%	0.46
20%	0.60
50%	1.00
60%	1.16
70%	1.37
80%	1.66

*Elements for which C_D , strength degradation ratio, is assumed to be 0.0

displacement capacity elements (i.e., those with an assumed strength degradation ratio of 0.0).

- Evaluate estimated seismic performance in comparison with spectral acceleration demand in accordance with Section 3.5.

3.3 Building Survey

The goal of the survey is to gather the information necessary to perform the simplified analysis and evaluation. The survey of the first story will require attention to detail similar to that required in Chapter 4 for the full evaluation. The upper-story survey, however, is intended to be much more limited.

3.3.1 First-Story Survey

The locations and lengths of the walls in the first story should be recorded. Only wall segments conforming to all of the following conditions should be considered:

- Wall segments
 - Are full-height from floor to floor,
 - Are greater than two feet long,
 - Have height-to-width ratios less than 8:1,
 - Are structurally connected to the floor above, and
 - Show no signs of significant deterioration or damage. (Deteriorated wall segments can be left out of the calculations.)

The layers of material that make up each wall should also be recorded and categorized using the sheathing types listed in Table 3-2. If the exact

Table 3-2 Strength Data for Sheathing Materials Considered

Material	ID	Strength (pounds/linear foot)
Stucco	L01	330
Horizontal wood sheathing or wood siding	L02	170
Diagonal wood sheathing	L03	910
Plaster on wood lath	L04	540
Plywood panel siding (T1-11)	L05	570
Gypsum wallboard	L06	210
Plaster on gypsum lath	L07	400
Wood structural panel 8d@6" on center	L08	840
Wood structural panel 8d@4" on center	L09	1,110
Wood structural panel 8d@3" on center	L10	1,690
Wood structural panel 8d@2" on center	L11	2,190
Wood structural panel 10d@6" on center	L12	1,070
Wood structural panel 10d@4" on center	L13	1,500
Wood structural panel 10d@3" on center	L14	1,990
Wood structural panel 10d@2" on center	L15	2,510

Source: Table 4-1 (maximum strength values rounded to nearest 10 pounds per linear foot).

sheathing type is not tabulated, the engineer may use judgment to choose the closest matching sheathing type. Some destructive investigation might be needed.

3.3.2 Upper-Story Survey

A survey of the upper stories should be only as detailed as necessary for the engineer to estimate the weight of the upper stories and the center of strength of the upper stories. This may include:

1. Overall building geometry, including plan dimensions and story heights,
2. The amount and composition of partitions contributing to the weight of the building, and
3. Floor assemblies.

3.4 Building Characterization

This section outlines the computations necessary to determine a few coefficients that characterize the building in preparation for the evaluation in Section 3.5. The task is to synthesize the information gathered during the building survey into numerical quantities that characterize the building.

These values will be used in Section 3.5 to evaluate the expected seismic performance.

3.4.1 Total Building Weight, W

The total weight of the building should be estimated. The engineer should use conventional assumptions for weights of building materials. The calculations should be consistent with the geometry and other information gathered about the building during the building survey.

3.4.2 Shear Strengths of First-Story Walls

Each conforming first-story wall identified in the building survey comprises one or more of the sheathing types listed in Table 3-2. The unit strength, v_s , is tabulated for each sheathing type (Table 3-2, right column). For walls with the same finish on each face, v_s for each face is to be included. Each wall segment should be assigned a unit strength, v_a , based on the sum of the strengths of each layer:

$$v_{a,w} = \sum v_s \quad (3-1)$$

where:

$v_{a,w}$ = unit shear strength of the wall assembly for wall w , and

$\sum v_s$ = sum of unit shear strengths of all the sheathing types in the wall assembly.

For simplicity reasons, this method of combining the strengths for each layer neglects the fact that test results indicate various finish layers reach their strength at different drift levels. The detailed evaluation method described in Chapter 4 does not neglect such behavior. While the above-specified method of combining is effectively non-conservative, the overall simplified procedure described in this chapter is considered conservative.

The total shear strength of each wall, f_v , should be calculated as the unit strength of the wall assembly times the wall length:

$$f_{v,w} = v_{a,w} L_w \quad (3-2)$$

where:

$f_{v,w}$ = shear strength of wall w , and

L_w = Length of wall w ; examples shown in Figure 3-1.

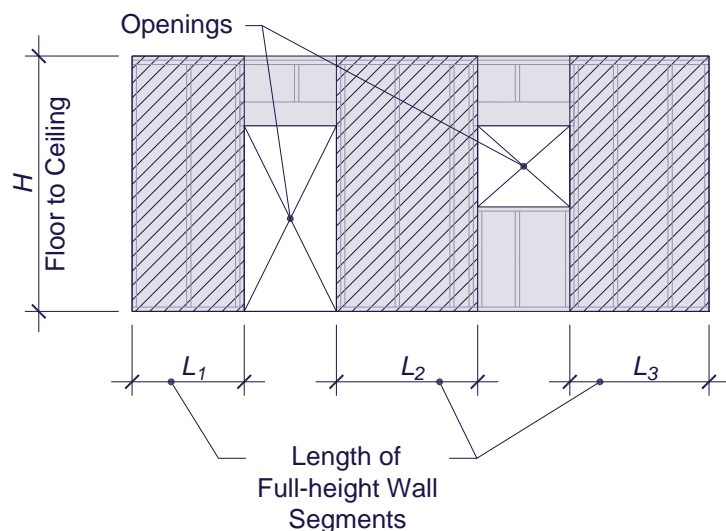

Figure 3-1 Illustration of wall lengths for an example wall line. In this case, $L_w = L_1 + L_2 + L_3$.

3.4.3 Shear Strength of First Story

The shear strength of the first story is computed for each direction as the sum of the strengths of the walls parallel to the direction under consideration. For walls at an angle to the primary wall directions, the projected length of the direction being considered should be used. The shear strength of the first story, V_I , is given by:

$$V_{I,x} = \sum f_{v,w,x} \quad 3-3$$

where:

$V_{I,x}$ = first-story shear strength in the direction x , and

$\sum f_{v,w,x}$ = sum of shear strengths of all walls parallel to the x -direction.

The first-story shear strength and the sum of shear strength of all walls in the y -direction are calculated similarly.

3.4.4 Center of Strength (COS_I) of First Story

The center of strength of the first story, COS_I , is defined to be the location of the force resultant of the wall strengths. For each wall, there is the point in plan, p_w , through which forces in that wall will act. This is the center of each wall. The position in plan that defines the center of strength in each story is given by:

$$COS_1 = \left(\frac{\sum_{w=1}^{N_{walls}} f_{v,w,y} p_{w,x}}{V_{1,y}}, \frac{\sum_{w=1}^{N_{walls}} f_{v,w,x} p_{w,y}}{V_{1,x}} \right) \quad (3-4)$$

where:

COS_1 = center of strength of the first story,

$f_{v,w,x}$ = component of shear strength of wall w , in direction x ,

$f_{v,w,y}$ = component of shear strength of wall w , in direction y ,

$p_{w,x}$ = x -coordinate of the center of wall w , and

$p_{w,y}$ = y -coordinate of the center of wall w .

3.4.5 Center of Strength (COS_2) of Upper Stories

For the purposes of the simplified evaluation, the center of strength of the upper stories, COS_2 , may be assumed to be the same as the geometrical centroid of the floor/roof diaphragm above the second floor.

3.4.6 Eccentricity

Typically, the centers of strength of the first story and upper stories will not be in the same location. If they are not, an eccentricity exists in one or both directions. The eccentricity is the absolute value of the difference in each component of the centers of strength:

$$e_x = |COS_{2,x} - COS_{1,x}| \quad (3-5)$$

where:

e_x = eccentricity in direction x ,

$COS_{1,x}$ = x -component center of strength of first story, and

$COS_{2,x}$ = x -component center of strength of upper stories.

A corresponding calculation is made to determine the eccentricity in direction y .

3.4.7 Simplified Torsion Coefficient, C_{Ts}

The simplified torsion coefficient takes into account the eccentricity of the structure under consideration. It is used in the evaluation to modify the expected seismic performance in Section 3.5.3. The simplified torsion coefficient is given by:

$$C_{Ts} = 4 \frac{e_x + e_y}{L_x + L_y} \quad (3-6)$$

where:

L_x = Length of the building in direction x , and

L_y = Length of the building in direction y .

3.5 Simplified Evaluation of Seismic Performance

The seismic performance is evaluated by comparing the simplified spectral acceleration capacity, S_c , which estimates the spectral acceleration at which unacceptable damage occurs, to the selected site-specific spectral acceleration demand. If the spectral-acceleration capacity is larger than the selected site-specific spectral acceleration demand, the building is deemed to satisfy the default (embedded) performance objective.

3.5.1 Site-Specific Spectral Acceleration Demand

The spectral acceleration demand is the short-period spectral acceleration corresponding to the earthquake hazard level of interest, as described in Section 3.2.2. The default (embedded) spectral acceleration demand is the MCE spectral acceleration for short periods (S_{MS}) from ASCE/SEI 7-05³. At sites classified as Site Class F, ASCE/SEI 7-05 requires the development of a site-specific acceleration design spectrum because its default spectrum might not be well-suited to soft or liquefiable soil. It was beyond the scope of these *Guidelines* to study the response of structures to soft-soil ground motions. However, it is expected that the conclusions and recommendations provided herein would still apply based on the following reasoning: the analytical study indicates that weak-story buildings behave much like single-mode structures, i.e., the relatively strong upper structure may be idealized as a rigid mass atop the weak first story. This single-mode behavior would be expected regardless of the ground-motion input, but the spectral acceleration demand on a soft-soil site may be larger at longer periods than at shorter periods. Thus, it is recommended that the maximum site-specific spectral acceleration (i.e., the largest spectral acceleration at any period) be used for the spectral acceleration demand. For sites classified Site Class F, the maximum site-specific spectral acceleration may be established in accordance with ASCE/SEI 7-05 Chapter 21.

³ Conceptually, the equivalent definitions in ASCE/SEI 7-10 for MCE and S_{MS} could also be used to define spectral acceleration demand.

3.5.2 Story Height Factor, Q_s

The seismic performance of a weak-story building is related to the height of the first story (see Appendix E for further discussion). The story height factor accounts for this. It is given by:

$$Q_s = 0.55 + 0.0047H \quad (3-7)$$

where:

H = Tallest height of any first-story wall, from floor to ceiling, in inches.

3.5.3 Simplified Spectral Acceleration Capacity, S_{cs}

The simplified spectral acceleration capacity should be computed in each direction. It is given by:

$$S_{cs,x} = \alpha_{POE,0} (1.47 - 0.73C_{Ts}) Q_s \left(\frac{V_{l,x}}{W} \right)^{0.6} \quad (3-8)$$

where C_{Ts} , Q_s , $V_{l,x}$, and W are defined above, and

$\alpha_{POE,0}$ = drift limit probability of exceed (*POE*) adjustment factor for low displacement capacity elements, with strength degradation ratio, $C_D = 0.0$, and

$S_{cs,x}$ = simplified spectral acceleration capacity in direction x .

This formulation requires the selection of a drift limit probability of exceedance (*POE*) level for the building, which is then used to determine the *POE* adjustment factor, $\alpha_{POE,0}$ (see Table 3-1), used in Equation 3-8.

3.5.4 Comparison of Demand Versus Capacity

The spectral acceleration capacity in each direction should be compared with the spectral acceleration demand consistent with the performance objective. Equation 3-9 and Equation 3-10 use the *Guidelines* default (embedded) performance objective and therefore use the MCE spectral acceleration for short periods (S_{MS}) from ASCE/SEI 7-05 as the demand; for further discussion on performance objectives, see Section 2.3.2 and Chapter 5.

$$S_{cs,x} \geq S_{MS} \quad (3-9)$$

$$S_{cs,y} \geq S_{MS} \quad (3-10)$$

Chapter 4

Structure Characterization for Detailed Evaluation

4.1 Introduction

Chapter 4 provides the procedure for characterizing the structure for the evaluation procedure of Chapter 5. The structure is characterized by five values:

- Base-normalized upper-story strength, A_U ,
- Weak-story ratio, A_W ,
- Strength degradation ratio, C_D ,
- Torsion coefficient, C_T , and
- Story height factor, Q_s .

Calculating these values requires information about the existing building collected in accordance with Section 4.3 and development of load-drift and load-rotation curves in accordance with Sections 4.4 through 4.6.

The *Guidelines* use the following conventions to designate specific floors and stories:

- The *first story* is the story being investigated as a potential weak story. It is frequently the ground story—that is, the story immediately at grade—but not always so, due to sloped sites, partial basements, or other conditions.
- The *upper stories* include all the stories above the first story. Frequently the second story is the most critical of these, but the *Guidelines* allow for the possibility that a story further up in the building might influence the evaluation results or the retrofit design.
- Story i is between floor i and floor $i+1$. Thus, story 1—the first story—is between floors 1 and 2. For the common condition where the first story is adjacent to grade on a flat site, ground level is the first floor, or floor 1.
- The subscript i is generally used to denote a floor or story.

- The subscript x is generally used to denote a plan direction, with the understanding that a building has two principal orthogonal directions, x and y .

4.2 Wall Materials

Buildings eligible for the *Guidelines* will have walls with a wide variety of sheathing materials. Wall materials likely to be encountered in older buildings include horizontal wood siding, horizontal and diagonal lumber sheathing, plaster over wood or gypsum lath, and stucco. Additional wall materials likely to be encountered in newer or remodeled buildings include gypsum wallboard and wood structural panel sheathing. While some of these are no longer common in new construction, all provide some level of strength and stiffness that should be considered in the evaluation and retrofit of existing buildings. Their contribution to strength and stiffness is particularly vital to the *Guidelines* methodology, in which story-to-story comparison of properties is paramount.

4.3 Detailed Building Survey

The purpose of the survey is to collect information required to calculate the building seismic weight and develop load-drift and load-rotation curves in accordance with Sections 4.4 through 4.6. Available drawings should be used to supplement the survey effort, but conditions depicted must still be field-verified.

An important part of data collection is identification and description of wall elements that contribute to the lateral strength and stiffness of the structure in each story. The following information is generally needed:

1. Wall locations and the size of wall openings. Wall segments less than one-foot long, or with height-to-width ratios greater than 8:1, should be neglected, as these are treated as openings when calculating wall line load.
2. Floor, roof, and wall assembly descriptions, to determine seismic weight, and to calculate overturning resistance where the simplified overturning adjustment factor is not applicable.
3. Diaphragm geometry, including locations of significant openings.
4. Wall sheathing materials.
5. Where sheathing is wood structural panel (WSP) or where sheathing load-drift data depends on nailing (see Section 4.4), nail size, and edge-nail spacing.

6. Condition of walls, with attention to any deterioration or damage. Quality of construction can also affect capacity; see Section 4.4.
7. Direction of floor and roof framing. This is necessary for the second floor and recommended at other floors for determining overturning resistance.
8. In buildings where hold-down hardware is anticipated, the locations of hold-down hardware and the adequacy of installation of representative hold-down types. Judgment should be exercised regarding the level of effort needed to identify the pattern of placement and representative locations.
9. Confirmation that walls are structurally connected for in-plane shear transfer at wall top and bottom. Check representative locations in the first story. Check representative locations in upper stories where there is reason to suspect walls might not be structurally connected. For non-WSP sheathing, the intent is to confirm that fastening reasonably conforms to conventional construction requirements. For existing WSP shear walls with nail spacing closer than six inches, it should be confirmed at representative locations that shear wall top and bottom connection capacity is reasonably in balance with the sheathing capacity.
10. Anchor bolts. At the base of the first story, verify that anchor bolts exist or that anchor bolts will be added as part of an alteration or retrofit.
11. Confirmation that walls have a load path to pick up or mobilize tributary dead load used to resist overturning. Check representative locations in the first story. Check representative locations in upper stories where there is reason to believe walls might not have bearing load path, such as conditions involving infill walls or long-span truss systems.

Some destructive investigation might be needed, especially to determine the construction of representative wall assemblies. For example, a typical interior wall could have two layers of lath and plaster or two layers of gypsum wallboard. A perimeter wall could consist of a layer of stucco, diagonal siding, and gypsum wallboard. Only intact lengths of sheathing should be counted toward the strength of a wall. Any portion along the length of a full-height pier of any layer of wall sheathing where capacity-reducing deterioration or damage exists should be excluded.

4.4 Load-Drift Curves for Common Sheathing Materials

The *Guidelines* rely on the concept of load-drift (or backbone) curves. A piecewise-linear curve is defined by a set of drift ratios and corresponding loads (lbs) or unit-loads (pounds per linear foot, plf) based on available test

information. The interstory drift ratios at the top of Table 4-1 represent the set of expected deformations, δ_j . Load-drift curve data for each sheathing material considered are tabulated in Table 4-1 and plotted in Figure 4-1, Figure 4-2, and Figure 4-3. As seen in Figures 4-1 and 4-2, the curves have been grouped into materials with high- and low-displacement capacity. See Appendix E for further discussion of this categorization.

Table 4-1 Load-Drift Curve Data for Sheathing Materials [pounds/linear foot]

Sheathing Material	ID	Interstory Drift Ratio, δ_j [%]								
		0.5	0.7	1.0	1.5	2.0	2.5	3.0	4.0	5.0
Stucco	L01	333	320	262	0					
Horizontal wood sheathing or wood siding	L02	85	96	110	132	145	157	171	0	
Diagonal wood sheathing	L03	429	540	686	913	0				
Plaster on wood lath	L04	440	538	414	391	0				
Plywood panel siding (T1-11)	L05	354	420	496	549	565	505	449	0	
Gypsum wallboard	L06	202	213	204	185	172	151	145	107	0
Plaster on gypsum lath	L07	402	347	304	0					
WSP, 8d@6" on center	L08	521	621	732	812	836	745	686	0	
WSP, 8d@4" on center	L09	513	684	826	943	1,018	1,080	1,112	798	0
WSP, 8d@3" on center	L10	1,072	1,195	1,318	1,482	1,612	1,664	1,686	1,638	0
WSP, 8d@2" on center	L11	1,393	1,553	1,713	1,926	2,096	2,163	2,192	2,130	0
WSP, 10d@6" on center	L12	548	767	946	1,023	1,038	1,055	1,065	843	0
WSP, 10d@4" on center	L13	707	990	1,275	1,420	1,466	1,496	1,496	1,185	0
WSP, 10d@3" on center	L14	940	1,316	1,696	1,889	1,949	1,990	1,990	1,576	0
WSP, 10d@2" on center	L15	1,120	1,568	1,999	2,248	2,405	2,512	2,512	2,231	0

Source: Appendix D, Table F-14.

Notes: Values in the shaded areas are interpolated or extrapolated from existing data.

WSP: Wood structural panel

The load-drift curves are based on available information from numerous sources described in Appendix D. As part of the *Guidelines* developmental project, engineering judgment was applied to reconcile the data, accounting for differences in loading protocol and testing conditions. Cautions are needed regarding several of the materials listed in Table 4-1.

- Values for plywood panel siding (often called “T1-11”) are for fastening in accordance with APA recommendations, which require one nail to connect two lapped sheets at vertical edges. Inadequate nailing is frequently and widely observed. Where nailing is inadequate, sheathing capacity should be reduced for calculations, or nailing should be corrected.

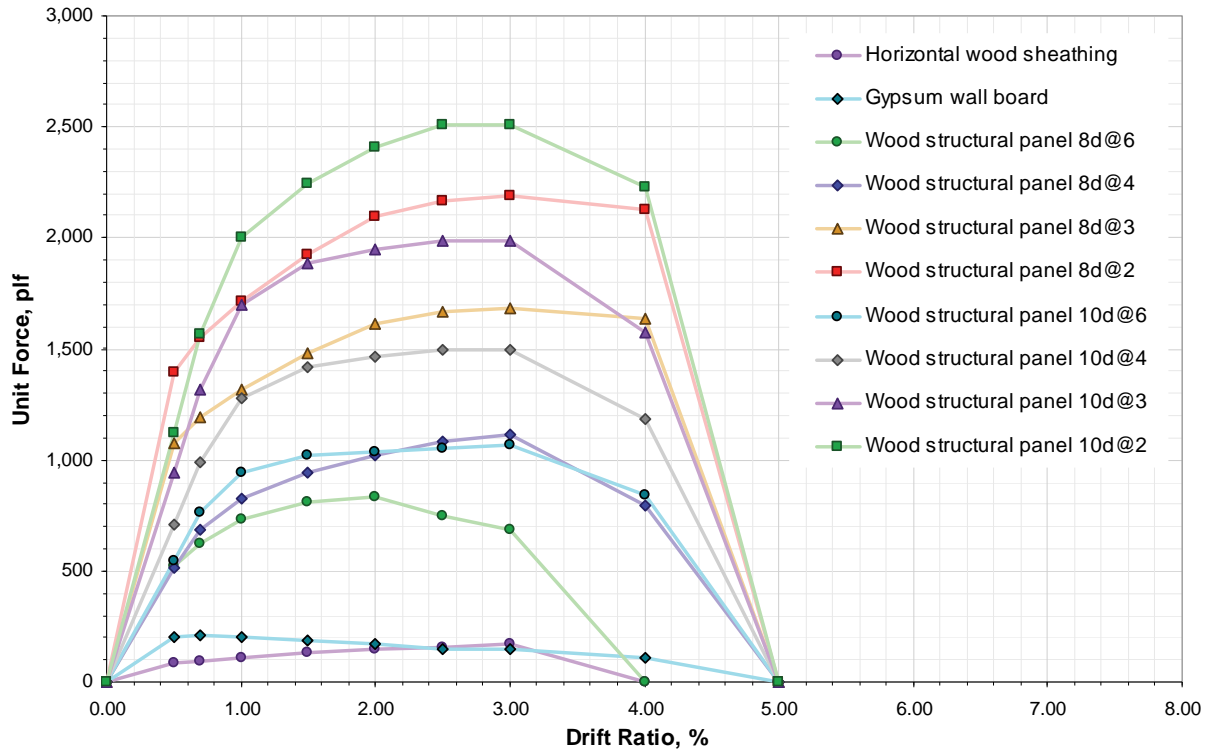

Figure 4-1 Unit load-drift curves for sheathing materials with high-displacement capacity. Wall-panel nailing notation: nail size (e.g., 8d) @ distance between center of nails in inches.

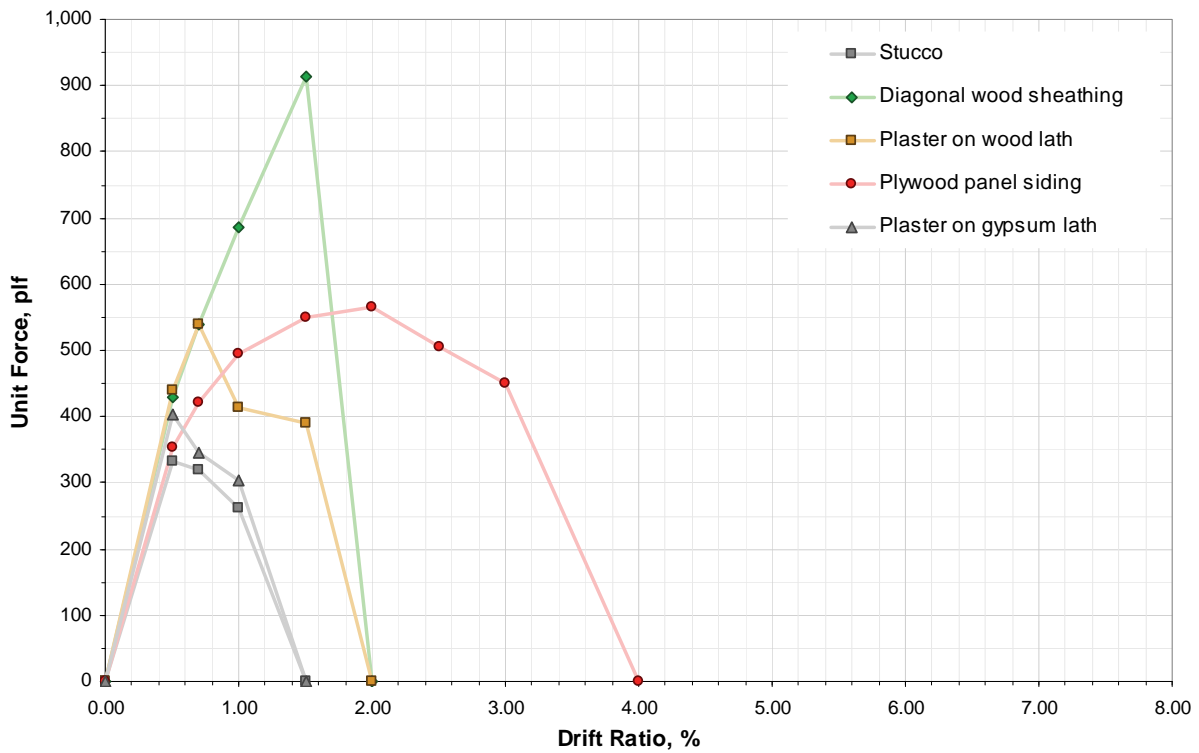

Figure 4-2 Unit load-drift curves for sheathing materials with low-displacement capacity.

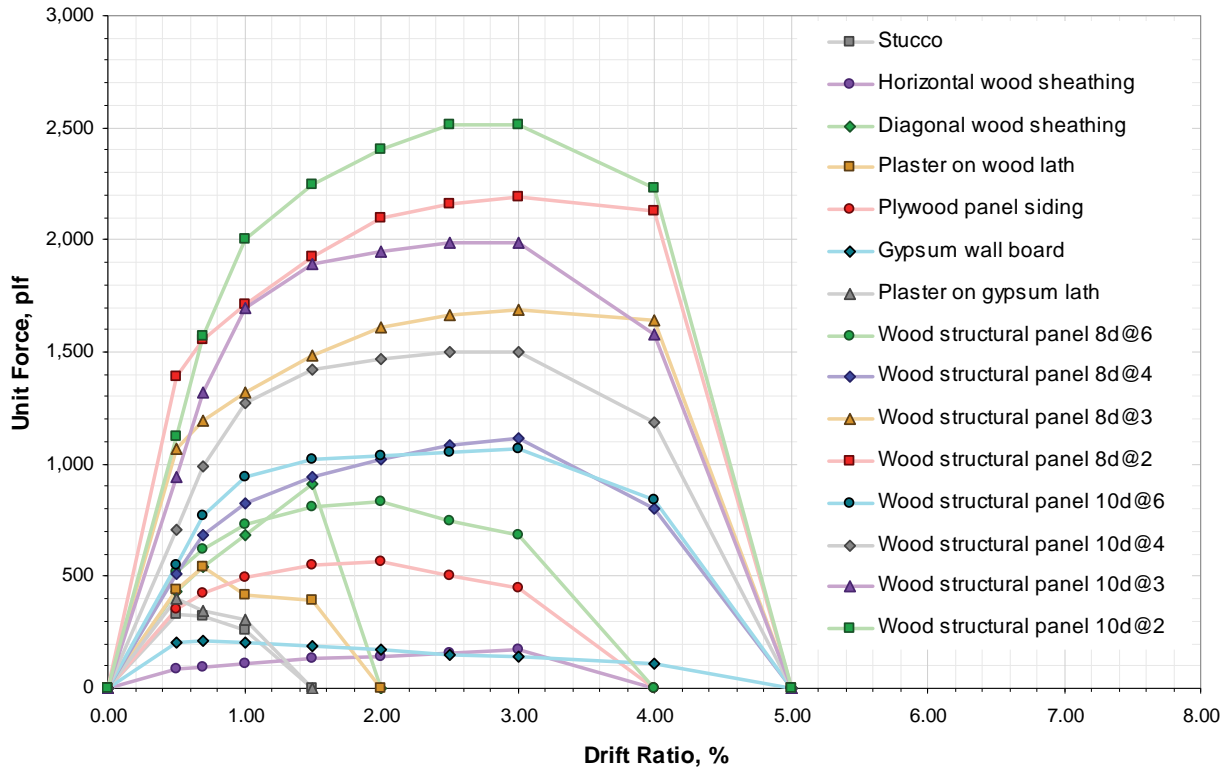

Figure 4-3 Unit load-drift curves for all sheathing materials considered; note the large differences in both peak strength and displacement capacities. Wall-panel nailing notation: nail size (e.g., 8d) @ distance between center of nails in inches.

- Stucco over self-furring lath has performed poorly in some cases, often due to poor quality construction. Several investigations after the Northridge earthquake found that the stucco was applied over the face of the wire rather than engaging it and penetrating behind it. Where a significant proportion of building, story, or wall-line capacity is provided by stucco with self-furring lath, the adequacy of construction should be verified, and where inadequacies are found, sheathing capacity should be reduced to reflect these inadequacies.

Finally, some materials should be ignored for the purpose of establishing load-drift curves.

- Hardboard siding has been tested by Pardoen, et al. (2003) as part of the CUREE-Caltech Woodframe Project and found to have negligible capacity.
- Steel sheet was used in the past to provide fire resistance for garage walls (especially in San Francisco), but its nailing is typically too light to make a contribution to wall strength.

- Veneer test results were not reviewed for inclusion in Table 4-1. In general, brick veneer should be ignored for purposes of calculating wall assembly and wall line strength. While the veneer itself might have significant strength and stiffness, the shear load path and connection to the rest of the wall assembly is insufficient, as it typically involves only weak wire ties incapable of transferring substantial forces.

See Appendix D for discussion of methods to develop load-drift curves for materials not included in Table 4-1.

4.5 Wall Line Load-Drift Curves

To quantify the load-drift behavior for each story and direction, wall segments within each story are assigned to wall lines, and a load-drift curve is established for each wall line. Wall segments combined into one wall line must meet all of the following requirements:

- Wall segments must occur in a single line, or have out-of-plane offsets not exceeding four feet.
- Wall segments must occur within continuous wall framing (top plates and studs). Where wall framing stops, wall segments on either side are to be assigned to separate wall lines. Party walls, with or without staggered studs may be considered the same wall line, provided the top and bottom of the wall are connected adequately to provide compatible deformations.
- Wall segments must be of constant height. Wall segments with varying height should be assigned to separate wall lines.
- Wall segments must be of a single sheathing assembly (that is, a single combination of sheathing materials).
- Steel moment frames should be considered to have their own wall lines.

The length of a wall line length should be taken as the longest possible length that satisfies these criteria. Where hold-downs exist at each end of a wall segment, that wall segment may be considered a separate wall line.

Where bay windows exist, the segments of wall within the common plane are considered to be in the same wall line, but the wall segments within the cantilevered portions of the bay are not counted toward the wall line capacity.

Once wall lines are defined, a load-drift curve is established for each wall line, adjusting for combinations of sheathing materials, openings, overturning restraint, and, for first-story walls, wall line height.

The load-drift curve for each upper story wall line is given by:

$$f_w(\delta_j) = [v_w(\delta_j)] L_w Q_{open} Q_{ot} \quad (4-1)$$

where:

- $f_w(\delta_j)$ = load-drift curve for wall line w , at drift ratio increment, δ_j ,
 $v_w(\delta_j)$ = unit load-drift curve for the wall line's combination of sheathing materials at drift ratio increment, δ_j , using default load-drift material data provided in Section 4.4, or other technically substantiated load-drift data
- L_w = length of wall line, out-to-out, including openings within the defined wall line,
- Q_{open} = adjustment factor for openings in accordance with Section 4.5.2, and
- Q_{ot} = adjustment factor for overturning in accordance with Section 4.5.3.

The load-drift curve for each first-story wall line is given by:

$$f_w(\delta_{jh}) = [v_w(\delta_{jh})] L_w Q_{open} Q_{ot} \quad (4-2)$$

where parameters have the same meaning as in Equation 4-1, except:

- $f_w(\delta_{jh})$ = load-drift curve for wall line w , at drift ratio increment δ_{jh} , the drift ratio increment adjusted for wall line height, h , in accordance with Section 4.5.4, and
- $v_w(\delta_{jh})$ = unit load-drift curve for the wall line's combination of sheathing materials at drift ratio increment, δ_{jh} , using default load-drift material data provided in Section 4.4, or other technically substantiated load-drift data.

As discussed in Section 4.4, wall capacity should be adjusted (by judgment) based on the extent of deterioration, damage, or inadequate construction, recognizing that it is not necessarily conservative to disregard questionable sheathing in the first story. As with the *Guidelines* eligibility rules in Section 2.6, these condition assessment discounts may be ignored in calculations if all relevant conditions are to be remediated through an alteration or retrofit project.

4.5.1 Load-Drift Curves for Combinations of Sheathing Materials

In general, the unit load-drift curve for an assembly of several sheathing types is constructed by simply adding the unit load-drift curves of each layer, taking the full value of each layer.

Assemblies that include wood structural panels, however, must be treated differently. Figure 4-4 shows such an assembly comprising three layers: gypsum wallboard sheathing, wood structural panels, and stucco. Tests have shown that when wood structural panels are combined with other sheathing materials in a wall assembly, the total strength is less than the sum of the strengths of individual layers. Wood structural panels can withstand high drift ratios before losing strength. Finish materials often lose strength at a drift ratio of 2 percent or less. Appendix Section D.5 discusses available data.

The composite load-drift curve for a wall assembly including wood structural panels is derived by constructing two load-drift curves, and selecting the one that has the larger peak strength. The two load-drift curves are:

- An assembly load-drift curve using 50 percent of the strength of the wood structural panel layers and 100 percent of the other sheathing materials, and
- An assembly load-drift curve using 100 percent of the strength of the wood structural panel layers and 50 percent of the other sheathing materials.

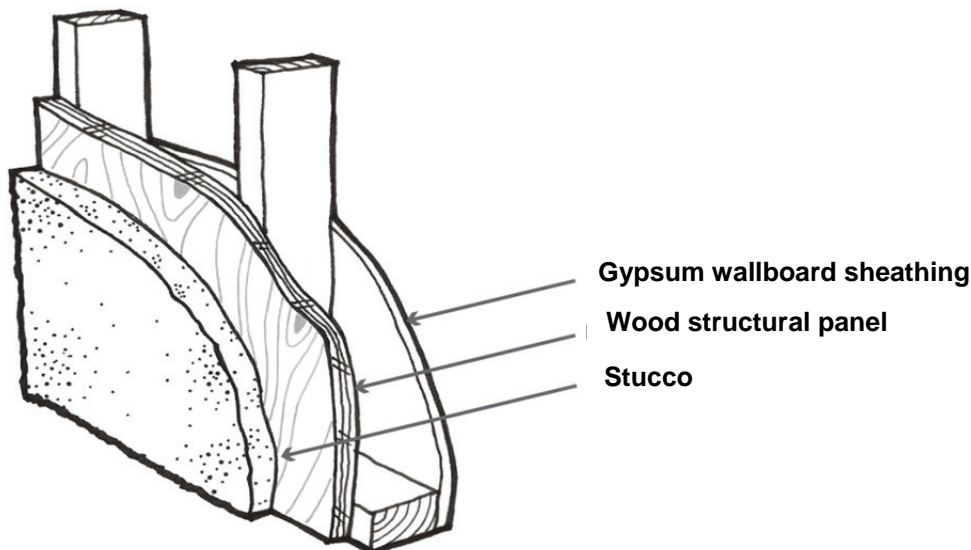

Figure 4-4 Schematic of a typical wall assembly composed of various layers. The capacity of the assembly is derived by combining the load-drift curves of the individual layers, while accounting for reductions due to interaction between wood structural panel (WSP) sheathing and other sheathing materials.

Figure 4-5 illustrates the composite unit load-drift curve for an example wall assembly made of three sheathing layers—wood structural panel sheathing, gypsum wallboard, and stucco—taking 100 percent of the wood structural panel unit loads plus 50 percent of the other layers’ unit loads. Figure 4-6 shows the composite load-drift curve taking 50 percent of the wood structural panel plus 100 percent of the other layers’ unit loads. Figure 4-7 shows both of the composite curves. In this example, the curve with 100 percent wood structural panel material plus 50 percent other materials has the higher peak load and it should be used to represent the load of this wall assembly at all drift levels (even those at which it drops below the other curve, as at drift ratios above 4 percent in Figure 4-7).

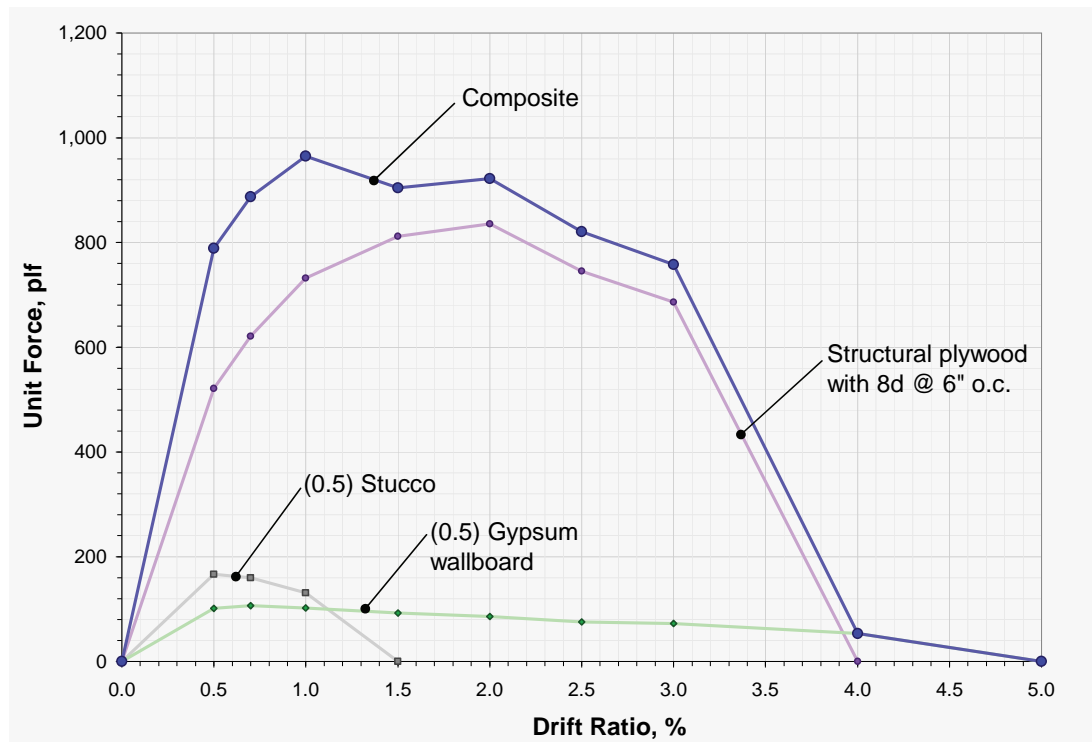

Figure 4-5 Composite unit load-drift curve of a wall assembly comprising stucco, gypsum wallboard, and wood structural panels (structural plywood in figure), using 100% of the wood structural panel (WSP) sheathing plus 50% of the other sheathing materials.

4.5.2 Adjustment Factor for Openings in the Wall Line

When wall piers are part of a common wall line as shown in Figure 4-8, the segments interact because of headers and sills that behave like coupling beams. Thus, a group of in-line wall segments linked at the top or bottom of an opening should be treated as one long wall, but with the capacity reduced

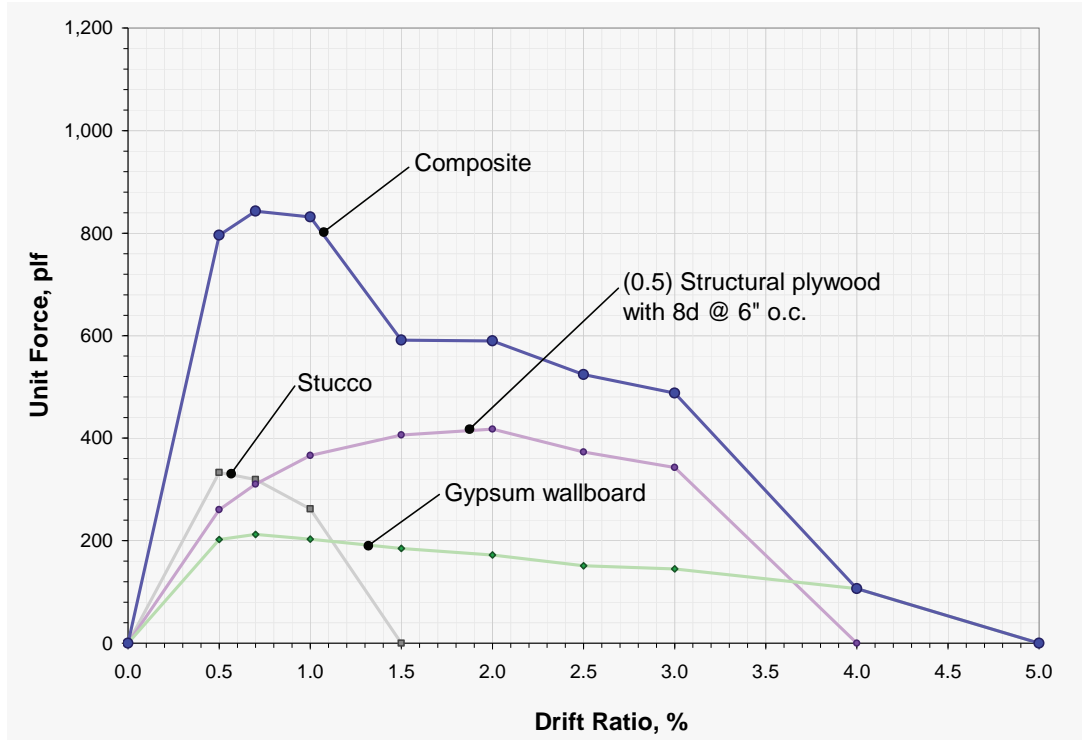

Figure 4-6 Composite unit load-drift curve of a wall assembly comprising stucco, gypsum wallboard and wood structural panels (structural plywood in figure), using 50% of the wood structural panel (WSP) sheathing plus 100% of the other sheathing materials.

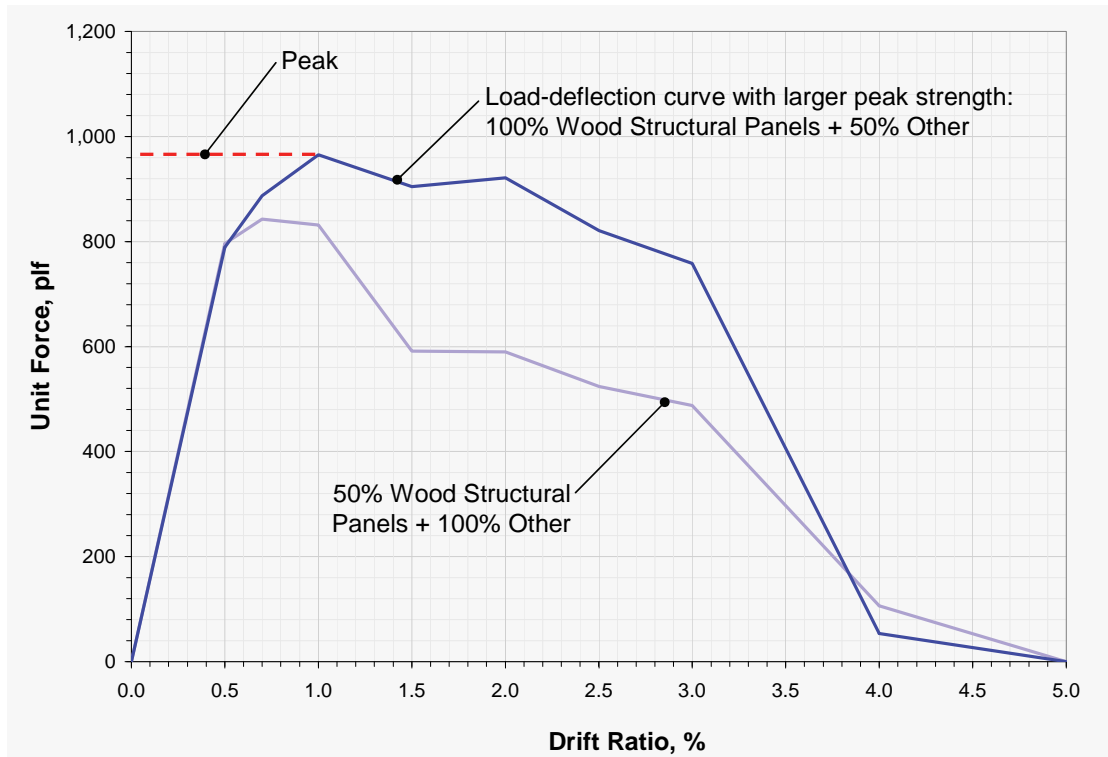

Figure 4-7 Controlling unit load-drift curve of a wall assembly comprising stucco, gypsum wallboard, and wood structural panels.

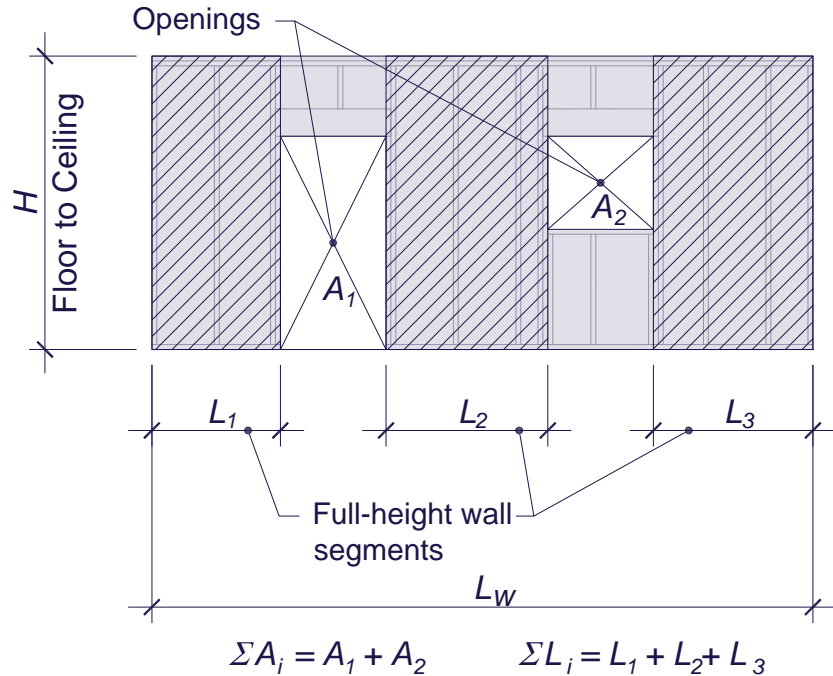

Figure 4-8 Wall schematic showing variables in the adjustment factor for openings. A denotes area.

to account for door and window openings. The adjustment factors are based on the area of openings relative to the area of full height wall segments. The reduction factor accounting for perforations, Q_{open} , is given by:

$$Q_{open} = 0.92\alpha - 0.72\alpha^2 + 0.80\alpha^3 \quad (4-3)$$

$$\text{where: } \alpha = \frac{1}{\left(1 + \frac{\sum A_i}{H \sum L_i}\right)} \quad (4-4)$$

and where:

$\sum A_i$ = sum of the areas of the openings,

H = Maximum floor-to-ceiling wall height, and

$\sum L_i$ = sum of the lengths of the full-height wall segments.

Where wall segments are less than one-foot long or have a clear height to length ratio of greater than 8:1, the area of the wall segment shall be included as an opening in $\sum A_i$.

The load-drift curve of a given wall is modified to account for openings by multiplying the unit force at each increment of drift ratio by Q_{open} as shown in Equations 4-1 and 4-2. Where the value, α , for a given wall line is less

than 0.5, the wall line must be broken into separate walls so that the value, α , for any wall line is greater than 0.5. This requirement is to keep walls reasonably compact so that the overturning adjustments calculated in Section 4.5.3 remain valid. See Appendix D, Section D.6, for further discussion of the adjustment factor for openings.

4.5.3 Adjustment Factor for Overturning

Because older buildings often do not have hold-down rods or straps to provide overturning resistance, the walls rely on other mechanisms to resist overturning demands. These include dead load, coupling beam effects above and below openings, and “shell effects” due to the interaction between perpendicular walls and floors. The unit load-drift curves defined in Section 4.4 presume full restraint against overturning (as would occur with an adequate hold-down device at each end of each shear-wall segment). Thus, wall line loads need to be adjusted in cases where the overturning restraint is insufficient to develop the peak shear strength.

Following adjustment for materials and openings, each wall line load-drift curve is adjusted for overturning in accordance with either Section 4.5.3.1 or 4.5.3.2.

4.5.3.1 Simplified Adjustment Factor for Overturning

The simplified adjustment factor for overturning, Q_{ot} , listed in Table 4-2, is applicable to upper stories only. The load drift curve for a given wall is modified by multiplying the unit force at each increment of drift ratio by the simplified factor for overturning given in Table 4-2. Tabulated values depend on the number of stories above the story under consideration and the span direction of floor or roof framing in the framing level immediately above the walls being considered.

Table 4-2 Simplified Adjustment Factor for Overturning

Simplified Adjustment Factor For Overturning, Q_{ot} , for Upper Story Wall Lines			
Number of stories above	Perpendicular to Framing	Parallel to Framing	Unknown or mixed
Two or more	0.95	0.85	0.85
One	0.85	0.80	0.80
None (Top story)	0.75	0.75	0.75

The simplified adjustment factors for overturning restraint were developed for conditions typical of residential occupancies characterized by frequent and well-distributed interior walls. Due to complex mechanisms including wall coupling and shell effects, available overturning restraint is generally

not well captured in standard engineering overturning calculations. The simplified factors provided in Table 4-2 were derived from push-over analysis of a four-story building model, described in Appendix E. Use of the simplified adjustment factor is recommended for upper stories unless the building does not have frequent and well-distributed interior walls, in which case use of the calculated adjustment factor for overturning restraint is recommended. The simplified adjustment factors should not be used for retrofit elements.

4.5.3.2 Calculated Adjustment Factor for Overturning

The calculated adjustment factor is used when the simplified adjustment factor of Section 4.5.3.1 is not used or does not apply.

The load-drift curve of a given wall line is modified by multiplying the unit force at each increment of drift ratio by Q_{ot} .

$$Q_{ot} = 0.4 \left(1 + 1.5 \frac{M_r}{M_{ot}} \right) \quad (4-5)$$

$$M_r = \frac{w_D L_w^2}{2} + P_D L_D + T_{HD} L_w \quad (4-6)$$

$$M_{ot} = V_w H \quad (4-7)$$

where:

- M_r = overturning resistance capacity of the wall line,
- w_D = uniform dead load tributary to wall line,
- w_D = uniform dead load tributary to wall line,
- P_D = concentrated dead load tributary to wall line,
- L_D = moment arm for concentrated load, P_D ,
- T_{HD} = tension ultimate capacity of tie-down hardware, if applicable,
- M_{ot} = overturning moment demand on the wall line,
- V_w = peak shear strength from the load-drift curve of the wall line under consideration, adjusted for openings (Section 4.5.2), and
- H = the floor-to-ceiling height of the wall line.

The overturning resistance includes potential contributions from hold-down hardware and tributary dead load (see Figure 4-9). For the contribution of the hold-down hardware, it is acceptable to use the ultimate capacity. Uniform and concentrated dead load contributions to resisting moment should be consistent with common design practice. The dead load tributary to the wall

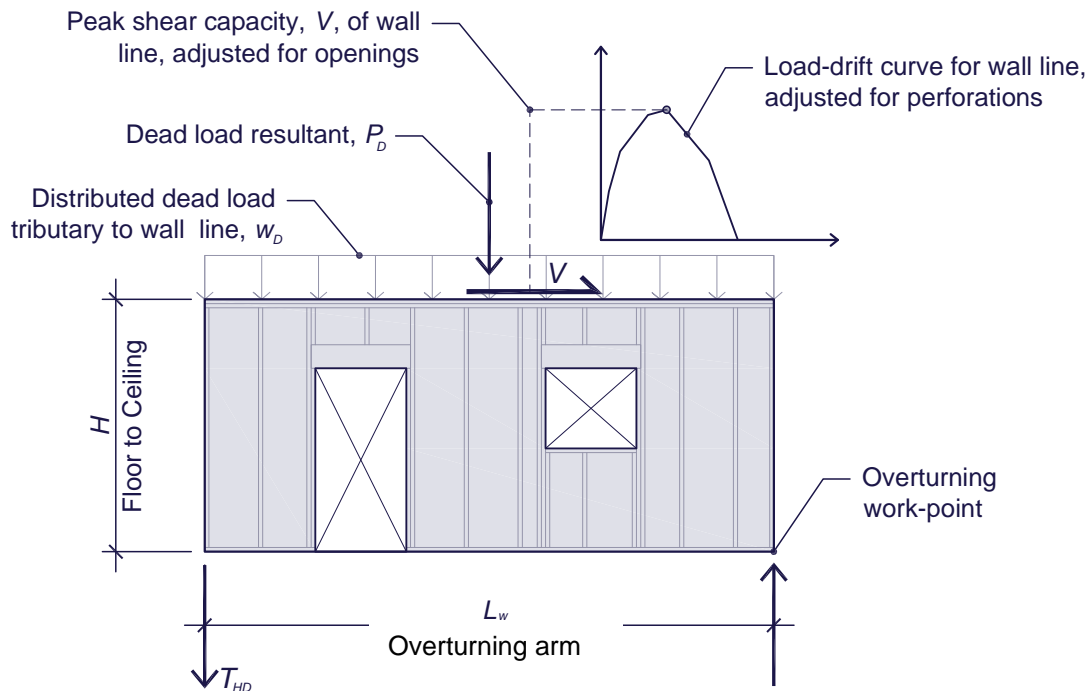

Figure 4-9 Wall schematic showing variables in the calculated adjustment factor for overturning.

line under consideration may include contributions from intersecting walls in the same story.

Equation 4-6 shows the general form of the formula for overturning resistance. In practice, the calculation should include as many uniform loads, w_D , and concentrated loads, P_D , as are needed to reflect the existing dead load, consistent with common engineering practice.

Following common engineering practice, the ratio M_r/M_{ot} may be calculated in either of two ways:

- Values of M_r and M_{ot} may be calculated considering only the story under consideration and loads tributary to the floor immediately above it, ignoring any overturning or resisting effects associated with stories further up the building, or
- Values of M_r and M_{ot} may be calculated considering the story under consideration and all floors and stories above it. In this case, M_r is a function of dead loads accumulated from multiple stories, and M_{ot} is a function of the strengths of stacked wall lines, each multiplied by the appropriate height (the overturning moment arm) above the base of the wall line under consideration. The strengths of the wall lines above contributing to M_{ot} should be adjusted for openings and overturning.

In no case should the ratio M_r/M_{ot} be taken greater than 1.0.

4.5.4 Drift Ratio Adjustment for First-Story Wall Line Height

If the first story includes wall lines with varying heights, and the story sways laterally without rotation, the shorter wall lines will experience greater drift ratios than the taller wall lines. To account for this effect, the load-drift curves for shorter wall lines need to be adjusted. The *Guidelines* do this by mapping the standard load-drift curve data from Table 4-1 onto a narrower range of drift values. The modified, or narrowed, drift increment values are given by:

$$\delta_{jh} = \delta_j \left[\frac{h}{H} \right]^{0.7} \quad (4-8)$$

where:

δ_{jh} = drift ratio at increment j , adjusted for wall height, h ,

δ_j = standard drift ratio at increment j (see Table 4-1),

h = floor-to-ceiling wall height of first-story wall line under consideration, with $h < H$, and

H = floor-to-ceiling wall height of the tallest wood-frame wall in the first story.

Figure 4-10 illustrates the effect of concentrating a uniform story displacement within the height of a shortened wall. Though wall line 1 and wall line 2 (recall, per Section 4.5, that wall segments of different heights are assigned to separate wall lines) have the same basic load-drift data and are subject to the same second floor displacement, they experience different amounts of distortion, or drift, relative to their height. The amplified drifts in wall line 2 are approximated by squeezing its load-drift curve into the height-adjusted drift range. See Appendix Section D.8 for further discussion.

The height adjustment in this section applies to every first-story wall line shorter than the tallest first-story wall line. That is, while Figure 4-10 shows two wall lines that happen to be actually aligned with each other, the adjustment of Equation 4-8 also applies to parallel wall lines anywhere within the first story.

An overall adjustment for a tall or short story is made separately, in Section 4.7.6, to adjust the first story as a whole relative to the standard story height of 8 ft on which most load-drift curve data are based.

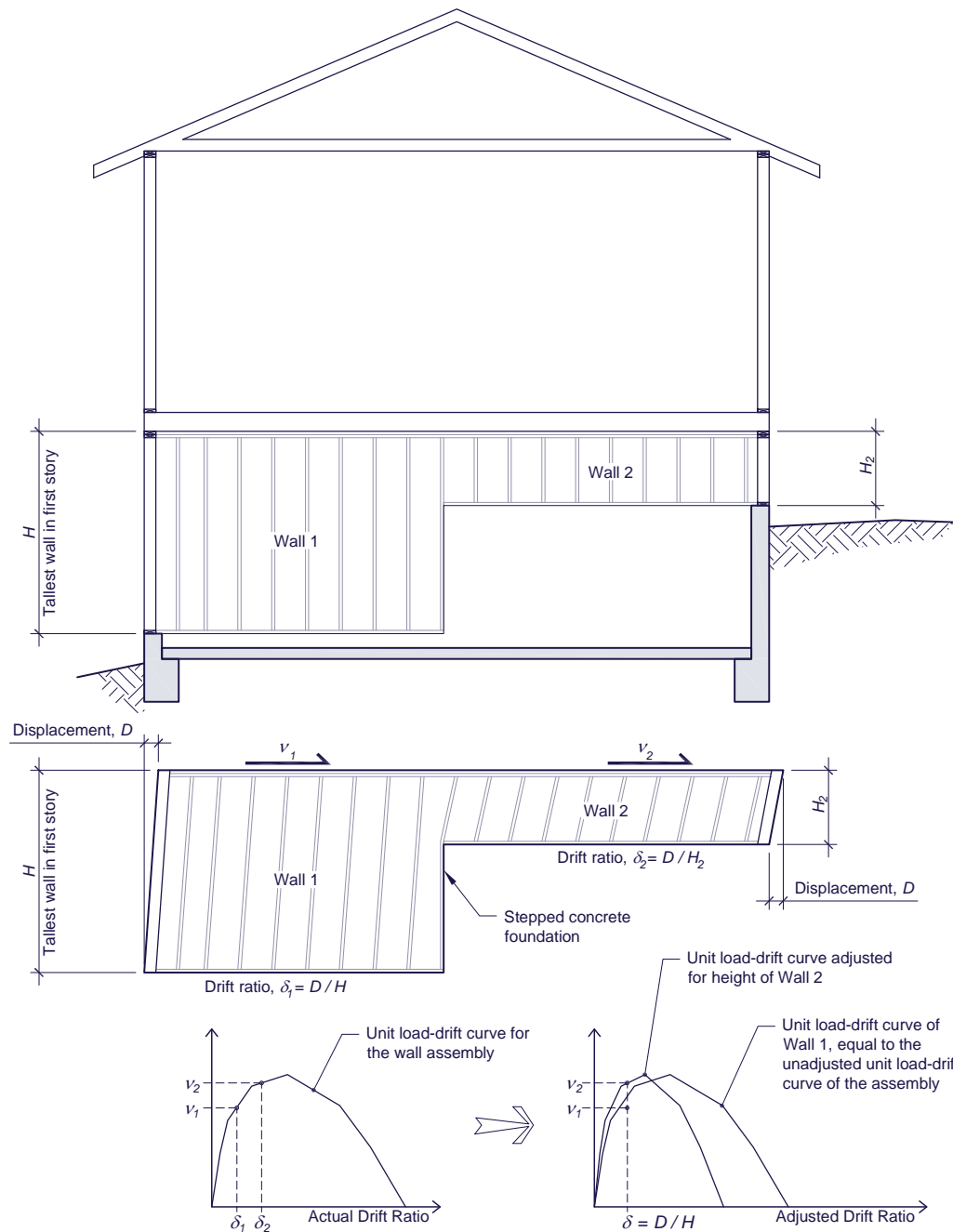

Figure 4-10 Wall schematics and load-drift curves illustrating drift adjustment parameters for varying first-story wall line heights.

4.6 Determine Strength of Each Story

4.6.1 Translational Load-Drift Curve

The load-drift curve for each story in each orthogonal direction is obtained by adding the loads in the load-drift curves for each wall line parallel to the direction of consideration at each increment of drift ratio, assuming twisting in plan is restrained. The load-drift curve for each story in each direction is

defined by the sum of the individual wall line load-drift curves in that direction:

$$F_{i,x}(\delta_j) = \sum_{w=1}^{N_{walls}} f_{w,x}(\delta_j) \quad (4-9)$$

where:

$F_{i,x}$ = load-drift curve for story i in direction x , over the range of drift ratio increments, δ_j ,

$f_{w,x}$ = component of load-drift curve for wall line w , in the x direction, over the range of drift ratio increments, δ_j , and

N_{walls} = total number of wall lines.

The load drift, $F_{i,y}$, for story i in direction y , is calculated similarly as the sum of the individual wall line load-drift curves in that direction.

Where all the wall line load-drift curves are mapped to the same set of drifts, the summation in Equation 4-9 is straightforward. Where some first-story wall lines have load-drift curves mapped to a height-adjusted set of drifts, per Section 4.5.4, load values at the standard drift increments, δ_j , should be determined by linear interpolation. Once interpolated values are calculated, the various load-drift curves can again be added in a straightforward way based on the standard drift increments.

Where a wall is not parallel to an orthogonal direction, the load-drift curve should be split into components aligned with the orthogonal directions.

As discussed in Section 2.6, existing structures with steel frames in the first story are eligible for the *Guidelines* methodology. In such cases, the story strength and load-drift curve would include a contribution from the steel frame as well. It is important that the characterization accurately account for actual or expected strength, and base fixity. For example, designating a “pinned” base is not conservative when assessing a semi-rigid condition.

4.6.2 Peak Strength

The peak translational strength of a story in each orthogonal direction is defined as the maximum load of the load-drift curve for that story (see Figure 4-11).

$$V_{i,x} = \max[F_{i,x}(\delta_j)] \quad (4-10)$$

where:

$V_{i,x}$ = peak translation strength of story i in direction x , and $F_{i,x}(\delta_j)$ is defined above; $V_{i,y}$, peak translation strength of story i in direction y , is calculated similarly.

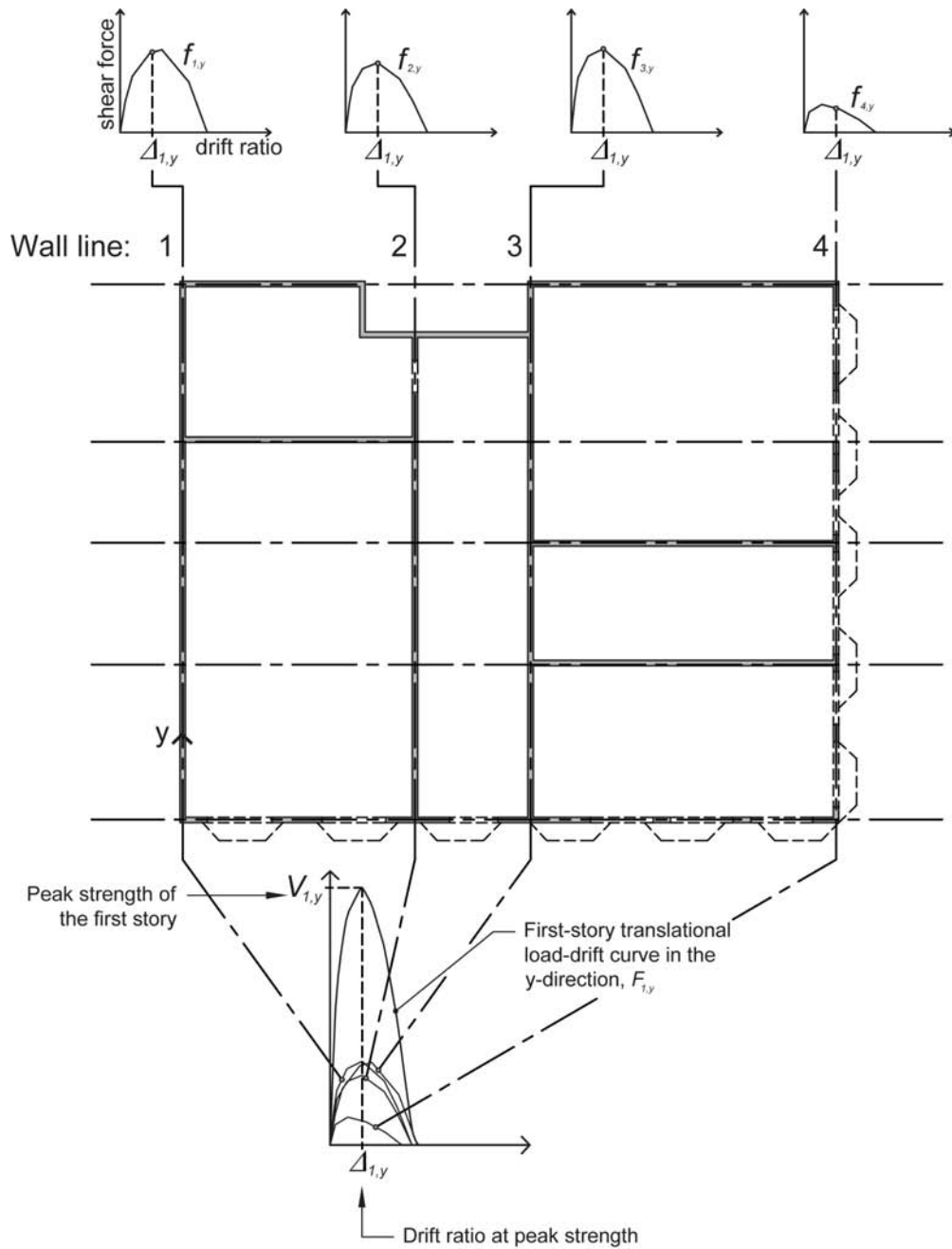

Figure 4-11 Wall-plan schematic with depiction of the first-story load-drift curve as the sum of first-story wall line load drift curves, y-direction.

4.6.3 Drift Ratio at Peak Strength

The drift ratio at peak strength, for a given story and direction, is:

$$\Delta_{i,x} = \delta_j \text{ at which } F_{i,x}(\delta_j) = V_{i,x} \quad (4-11)$$

where:

$\Delta_{i,x}$ = drift ratio at peak strength for story i , in direction x .

Values in direction y are calculated similarly.

In each orthogonal direction, the drift ratio at peak strength is a single value that applies to an entire story. This drift ratio could be more or less than the drift corresponding to the peak strength of any individual wall line, as shown in Figure 4-11.

4.6.4 Center of Strength

A story's center of strength is the location of the force resultant of the forces in the individual wall lines (under translation and allowing no rotation) at the drift ratio at peak strength, defined in Section 4.6.3. It is similar to the familiar concept of the center of rigidity, but with a focus on strength instead of stiffness. See Figure 4-12.

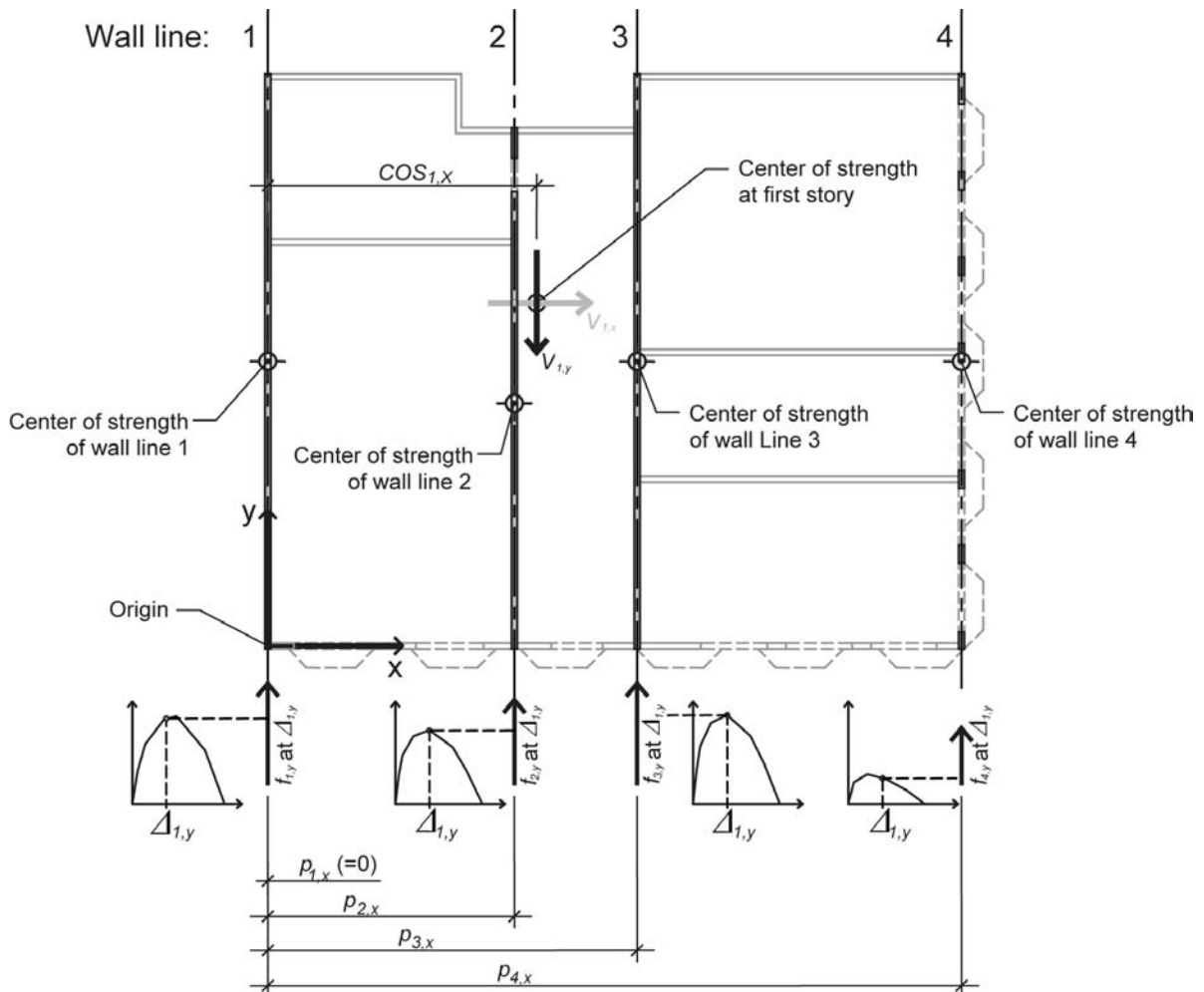

Figure 4-12 Wall-plan schematic showing location of center of strength at the first story. Wall lines in the y -direction determine the x -component of the center of strength.

The center of strength, COS_i , is computed for each story. For each wall in the story under consideration, there is the point in plan, p_w , through which forces

in that wall will act. This defines the center of each wall. Each wall line is assigned the force from its load-drift curve corresponding to the drift ratio at the story's peak strength, Δ . The coordinates of the story's center-of-strength are then given by:

$$COS_i = \left[\frac{\sum_{w=1}^{N_{walls}} f_{w,y}(\Delta_{i,y}) p_{w,x}}{V_{i,y}}, \frac{\sum_{w=1}^{N_{walls}} f_{w,x}(\Delta_{i,x}) p_{w,y}}{V_{i,x}} \right] \quad (4-12)$$

where $f_{w,x}$, and $\Delta_{i,x}$, are defined above and:

$f_{w,y}$ = component of load-drift curve for wall line, w , in the y -direction,

$\Delta_{i,y}$ = drift ratio at peak strength for story i , in direction y ,

COS_i = center-of-strength of story i ,

$p_{w,x}$ = x -coordinate of the center of wall w , and

$p_{w,y}$ = y -coordinate of the center of wall w .

4.6.5 Torsional Eccentricity at the First Story

The torsional eccentricity for a story is the distance between the centers of strength of that story and the story above. Thus, for the first story, the two components of the eccentricity are:

$$e_x = |COS_{2,x} - COS_{1,x}| \quad (4-13)$$

$$e_y = |COS_{2,y} - COS_{1,y}| \quad (4-14)$$

where:

$COS_{i,x}$ = x -coordinate of the center of strength of story i ,

e_x = x -component of the torsional eccentricity

e_y = y -component of the torsional eccentricity

This strength-based definition of torsional eccentricity differs from the conventional definition based on rigidity. However, both address the tendency of the second floor to twist relative to the ground.

4.6.6 Load-Rotation Curve

The load-rotation curve of the first story gives the torque required to twist the first story about its center-of-strength, assuming that the base of each first-story wall line is fixed. See Figure 4-13. This is similar to a story load-drift curve, except for twist instead of translational drift. The range of twist angles to be considered depends on the geometry of the wall layout.

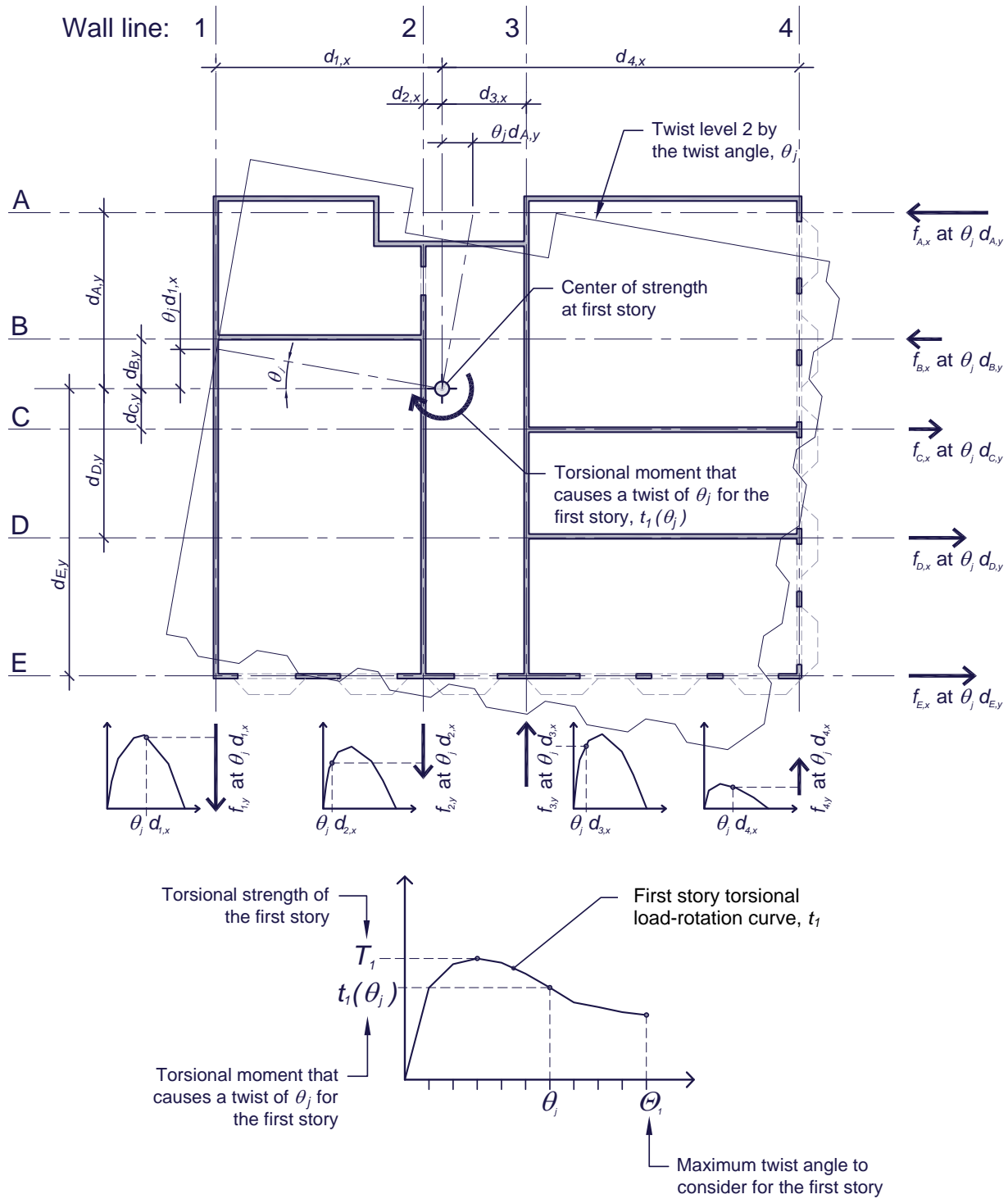

Figure 4-13 Wall-plan schematic and related torsional-load rotation curves illustrating how the first story load-rotation curve is computed.

The distance, d , at which each wall line acts to contribute to a story's twist is defined, in the case of direction x , as:

$$d_{w,x} = p_{w,x} - \text{COS}_{l,x} \quad (4-15)$$

where $p_{w,x}$ and $COS_{i,x}$ are defined above, and:

$d_{w,x}$ = distance between the center of strength of wall w , and the center of strength of the first story, in the x -direction.

The distance between the center of strength of wall w , and the center of strength of the first story, in the y -direction, $d_{w,y}$, is calculated similarly.

The maximum angle of twist considered by the *Guidelines* is related to a 5 percent translational drift ratio and is given by:

$$\Theta = \frac{0.05H_{F1}}{\max[d_w]_{w=1 \rightarrow N_{walls}}} \quad (4-16)$$

where:

Θ = maximum angle of twist to consider, in radians

H_{F1} = maximum story height of the first story, floor to floor

d_w = distance between the centers of strength of the first story and wall w .

Equation 4-16 ensures that the wall farthest in plan from the center of strength is evaluated well past its peak strength. A horizontal deflection of 0.05 times the story height produces a 5 percent drift for the farthest wall. All other walls would have less than 5 percent drift. To understand the relationship of story torsion as the twist angle increases and wall lines reach their peak strengths, it is necessary to consider a number of twist angles between zero and the maximum. In most cases a set of angles in ten even increments is convenient and is expected to be sufficient:

$$\theta_j = \frac{j}{10} \Theta \quad (4-17)$$

where:

θ_j = twist angle j , at which to evaluate the load-rotation curve.

j = index ranging from 0 to 10.

The first-story load-rotation curve is given by:

$$t_1(\theta_j) = \sum_{w=1}^{N_{walls}} \left[d_{w,y} f_{w,x} \left(\frac{d_{w,y} \theta_j}{H_{F1}} \right) + d_{w,x} f_{w,y} \left(\frac{d_{w,x} \theta_j}{H_{F1}} \right) \right] \quad (4-18)$$

where all variables are defined above.

4.6.7 Torsional Strength

The torsional strength of the first story, T_1 , is the maximum torque from the load-rotation curve:

$$T_1 = \max [t_1(\theta_j)] \quad (4-19)$$

4.6.8 Torsional Demand

The torsional demand on the first story is calculated by multiplying the translational strength of the first story by the eccentricity, as illustrated in Figure 4-14. It is given by:

$$\tau_1 = e_x V_{1,y} + e_y V_{1,x} \quad (4-20)$$

where all variables are defined above.

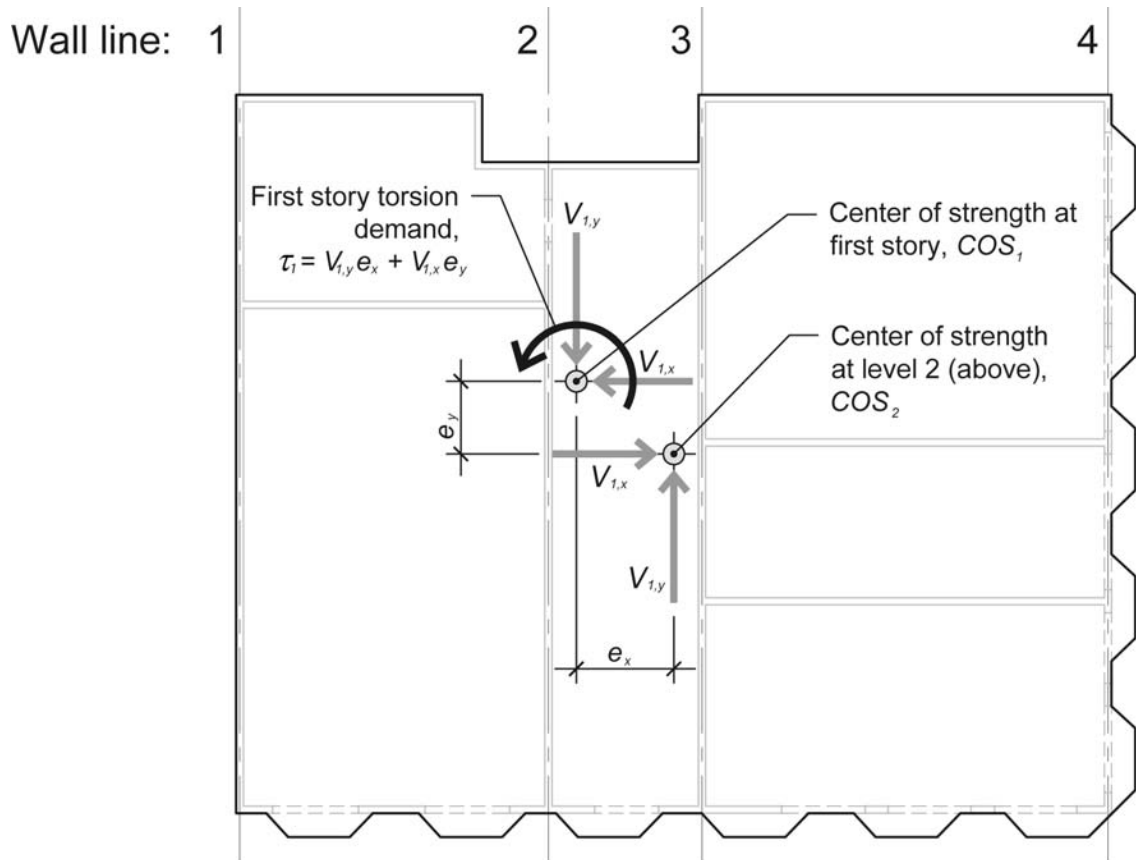

Figure 4-14 Wall-plan schematic depicting how the torsional demand on the first story is calculated.

4.7 Characteristic Coefficients

In this section, various coefficients are defined based on the properties and relationships described in Section 4.6. These coefficients are used in Chapter 5 to evaluate the structure and in Chapter 6 to estimate the appropriate retrofit strength.

4.7.1 Normalized First-Story Strength

The *Guidelines* use two methods to normalize story strength:

- The story-normalized strength, C_i , is the peak strength of story i divided by the seismic weight carried by story i . Thus, the normalizing value—the carried weight—varies from story to story.
- The base-normalized strength, A_i , is the peak strength of story i divided by the total seismic weight of the building. The normalizing value is the same no matter which story is being considered.

At the first story, where the seismic weight carried by the story is the seismic weight of the whole building, the two values are the same. In the x -direction, the value is given by:

$$C_{1,x} = A_{1,x} = \frac{V_{1,x}}{\sum_{j=2}^{N_s+1} W_j} \quad (4-21)$$

where:

N_s = total number of stories in the building

$V_{1,x}$ = the peak first-story strength in the x direction

W_j = seismic weight tributary to or assigned to floor j .

The value in the y -direction is calculated similarly.

4.7.2 Normalized Upper-Story Strength

The smallest of the C_i values for any of the upper stories is given a special designation, C_U . In the x -direction it is given by:

$$C_{U,x} = \min \left(\frac{V_{i,x}}{\sum_{j=i+1}^{N_s+1} W_j} \right)_{i=2 \rightarrow N_s} \quad (4-22)$$

In typical regular buildings, the story strengths are roughly the same in all the upper stories, and the seismic weight is greater toward the lower stories, so $C_{U,x}$ is usually the story-normalized strength of the second story, $C_{2,x}$.

The term A_U refers to the base-normalized strength of the controlling upper story (that is, the story that defines C_U):

$$A_{U,x} = \frac{V_{U,x}}{W} \quad (4-23)$$

where:

$V_{U,x}$ = the strength, in the x -direction, of the upper story that defines $C_{U,x}$

W = total seismic weight of the building.

Comparable parameters for the y -direction are calculated similarly.

4.7.3 Weak-Story Ratio, A_W

The weak-story ratio, A_W , compares the first-story strength to the critical upper-story strength. In the x -direction, it is given by:

$$A_{W,x} = \frac{V_{1,x}}{V_{U,x}} \quad (4-24)$$

where $V_{1,x}$ and $V_{U,x}$ are defined above.

The weak-story ratio in the y -direction ($A_{W,y}$) is calculated similarly, using $V_{1,y}$ and $V_{U,y}$ values.

4.7.4 Strength Degradation Ratio, C_D

The strength degradation ratio, C_D , characterizes the ability of the first story to maintain strength over large drifts. The loss of lateral strength at high drift ratios has a significant impact on seismic performance. C_D is the ratio of the strength at 3 percent drift (a convenient value to distinguish stories that can achieve high deformation from those that cannot) divided by the peak strength from the load-drift curve (see Figure 4-15). In the x -direction it is given by:

$$C_{D,x} = \frac{F_{1,x}(\delta = 3\%)}{V_{1,x}} \quad (4-25)$$

where $F_{1,x}$ and $V_{1,x}$ are defined above.

The strength degradation ratio in the y -direction, $C_{D,y}$, is calculated similarly, using values of $F_{1,y}$ and $V_{1,y}$, as defined above.

4.7.5 Torsion Coefficient, C_T

The torsion coefficient, C_T , is the ratio of torsional demand to torsional strength in the first story. It characterizes the vulnerability to lateral instability due to twist, where a larger ratio represents greater vulnerability. It is given by:

$$C_T = \frac{\tau_1}{T_1}; \text{ need not be taken greater than 1.4} \quad (4-26)$$

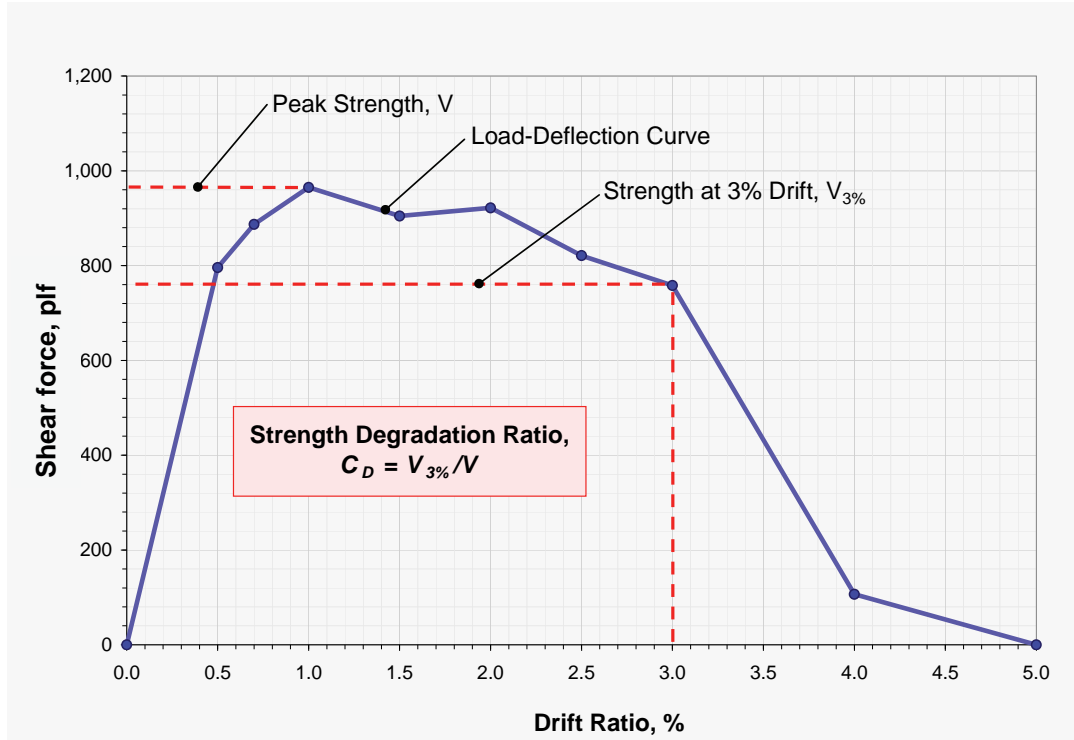

Figure 4-15 Load-drift curve depicting determination of strength degradation ratio, C_D .

where T_1 and τ_1 are determined as given in Sections 4.6.7 and 4.6.8, respectively.

4.7.6 Story Height Factor, Q_s

The *Guidelines* methodology relies on performance data from laboratory tests of various sheathing materials and assemblies (see Appendix D). Most of these data were derived from, or have been adjusted to, standard wall heights of 8 ft. As discussed further in Appendix E, buildings with different story heights will perform differently under the same ground motions or imposed displacements; shorter stories will exceed pre-set drift limits at a higher rate.

The *Guidelines* account for this effect with a story height factor, Q_s , which adjusts the actual story height relative to the 8-ft height used in the tests and the surrogate models. It is given by:

$$Q_s = 0.55 + 0.0047 H \quad (4-27)$$

where:

H = tallest height of any first-story wall, floor to ceiling, in inches.

The adjustment of Equation 4-27 applies to a whole story. Relative adjustment for wall lines of varying heights within the first story is addressed in Section 4.5.4.

This chapter uses the parameters defined in Chapter 4 to evaluate an existing structure. Figure 5-1 illustrates the content of the chapter and its relationship to other *Guidelines* chapters.

5.1 Evaluation Steps

The *Guidelines* evaluate an existing structure by comparing its capacity, estimated from the parameters defined in Chapter 4, with a demand. This is done in three steps that reflect components of the performance objective. As discussed in Section 2.3, the *Guidelines* measure performance in terms of transient interstory drift. Using a fragility-based methodology, the *Guidelines* address a performance objective stated as a maximum probability of exceeding certain drift limits at a specified level of ground motion. Thus, the three evaluation steps cover the three quantities that must be specified—the drift limits, the allowed probability of exceeding them, and the ground motion of interest:

- Calculate the median capacity of the structure (Section 5.2). Given in spectral acceleration terms, the median capacity is the level of shaking at which the specified drift limits are exceeded with 50 percent confidence. The *Guidelines'* formulas for the median spectral acceleration capacity have embedded in them a set of default drift limits representing the onset of strength loss.
- Calculate the spectral acceleration capacity of the structure, accounting for the targeted probability of exceeding the drift limits (Section 5.3). This calculation is made by applying an adjustment factor to the median capacity.
- Compare the spectral acceleration capacity to the site-specific acceleration demand (Section 5.4.1).

The *Guidelines* evaluation provisions focus on the strength of vertical elements of a structure's seismic force-resisting system. Satisfactory performance of any structure also requires adequate performance of diaphragms and load path components, as well as reliable detailing and construction quality in the walls themselves. The *Guidelines* do not require explicit evaluation of these issues. Instead, they assume that the eligibility

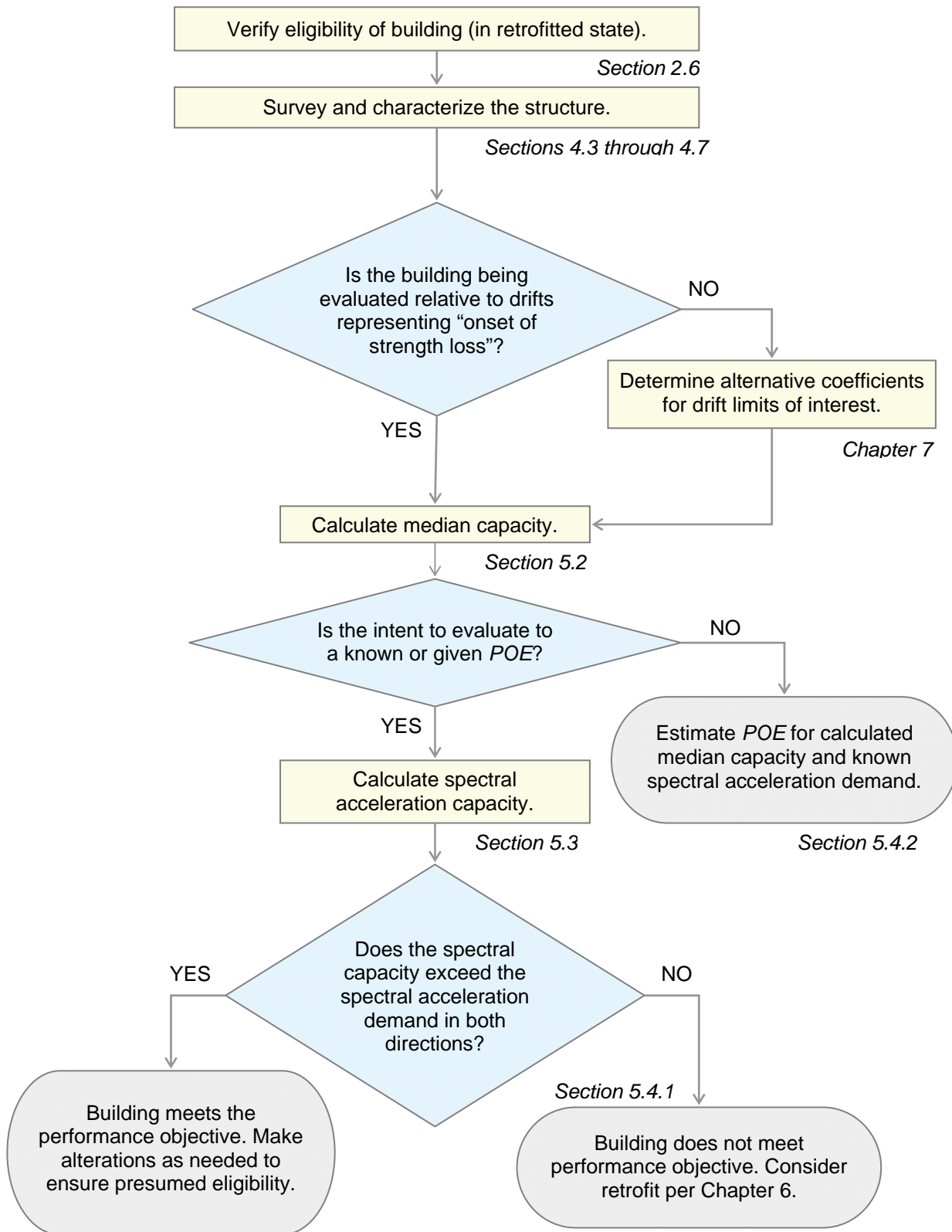

Figure 5-1 Flowchart of typical evaluation procedure.

requirements in Section 2.6 and the building survey scope in Section 4.3 provide an implicit evaluation. Corrections, improvements, or assumptions required by those sections are expected to be sufficient to support the evaluation procedure in this chapter. This assumption is expected to hold for the *Guidelines'* default performance objective involving the onset of strength loss drift limits, especially where the purpose of evaluation is to find buildings with dominant weak-story or open-front deficiencies. If a more conservative evaluation objective is applied, or if the evaluation program is intended to be more general and comprehensive, more thorough load path evaluation and condition assessment might be warranted. This is because higher performance (for example, involving onset of damage drift limits) or general evaluation (for example, involving nonstructural components or upper story deficiencies) might rely on conditions considered secondary here.

5.2 Calculate the Median Spectral Acceleration Capacity

The median spectral acceleration capacity, S_{μ} , is calculated for the two extreme values of the strength degradation ratio, C_D , in each of the two directions, x and y :

$$S_{\mu 1} = (0.525 + 2.24A_w)(1 - 0.5C_T)Q_s A_U^{0.48} \text{ for } C_D = 1.0 \quad (5-1)$$

$$S_{\mu 0} = (0.122 + 1.59A_w)(1 - 0.5C_T)Q_s A_U^{0.60} \text{ for } C_D = 0.0 \quad (5-2)$$

where:

A_w = weak-story ratio, defined in Section 4.7.3

A_U = base-normalized upper-story strength, defined in Section 4.7.2

C_T = torsion coefficient, defined in Section 4.7.5

Q_s = story height factor, defined in Section 4.7.6

(The median spectral acceleration capacity for intermediate values of C_D can be calculated using an interpolation similar to Equation 5-5, but that step is not strictly necessary because the interpolation will be done on the spectral acceleration capacity, as shown below.)

Equations 5-1 and 5-2 are essentially regression relationships that relate the structure in question to the surrogate models. Their derivation is described further in Appendix E. Embedded within these equations are default limits on interstory drift. As described in Section 2.2.1 and Appendix E, the default limits (1.25 percent for $C_D = 0.0$ and 4.0 percent for $C_D = 1.0$) correspond to the onset of strength loss for each of the two material models. Onset of strength loss is an element-specific condition assumed to indicate a

substantially increased potential for collapse. Chapter 7 provides factors to adjust the capacity formulas for different drift limits.

Equations 5-1 and 5-2 show that a structure's median spectral acceleration capacity is related to its upper-story strength, its weak-story ratio, its torsional vulnerability and its propensity to degrade. Median capacity most strongly corresponds to high first-story strength, low torsional demands and ductile materials (C_D near 1). Capacity increases as:

- weak-story ratio, A_w , increases, i.e., as the first- and upper-story strengths become closer,
- the base-normalized upper-story strength, A_U , increases,
- the strength degradation ratio, C_D , increases, and
- the torsion coefficient, C_T , decreases.

5.3 Calculate the Spectral Acceleration Capacity

Determination of the spectral acceleration capacity requires the selection of a drift limit probability of exceedance (*POE*). As discussed in Section 3.2.2, the drift limit *POE* is part of a defined performance objective.

In each direction, the spectral acceleration capacity, S_c , is then calculated for the two extreme values of the strength degradation ratio, C_D , by applying a drift limit probability of exceedance (*POE*) adjustment factor to the corresponding median spectral acceleration capacity, as shown in Equations 5-3 and 5-4. The spectral acceleration capacity for the structure's actual value of C_D is determined by interpolation with Equation 5-5.

$$S_{c1} = \alpha_{POE,1} S_{\mu1} \text{ for } C_D = 1.0 \quad (5-3)$$

$$S_{c0} = \alpha_{POE,0} S_{\mu0} \text{ for } C_D = 0.0 \quad (5-4)$$

$$S_c = C_D^3 S_{c1} + (1 - C_D^3) S_{c0} \text{ for intermediate values of } C_D \quad (5-5)$$

where $\alpha_{POE,1}$ and $\alpha_{POE,0}$ are the drift limit *POE* adjustment factors taken from Table 5-1 with linear interpolation as needed for intermediate values of the targeted *POE*.

Figure 5-2 shows how spectral acceleration capacity varies for different combinations of the key parameters A_U , A_w , and C_D . All four of the curves in the figure assume a drift limit *POE* of 20%.

The drift limit *POE* adjustment factors come from the fragility curves derived from the surrogate model analyses (see Appendix E). Each fragility curve is a log-normal cumulative distribution function of the spectral

Table 5-1 Drift Limit Probability of Exceedance (POE) Adjustment Factors

Targeted <i>POE</i>	Targeted Confidence Level (100% – Targeted <i>POE</i>)	$\alpha_{POE,1}$	$\alpha_{POE,0}$
2%	98%	0.36	0.29
5%	95%	0.44	0.37
10%	90%	0.53	0.46
20%	80%	0.66	0.60
50%	50%	1.00	1.00
60%	40%	1.14	1.16
70%	30%	1.30	1.37
80%	20%	1.52	1.66

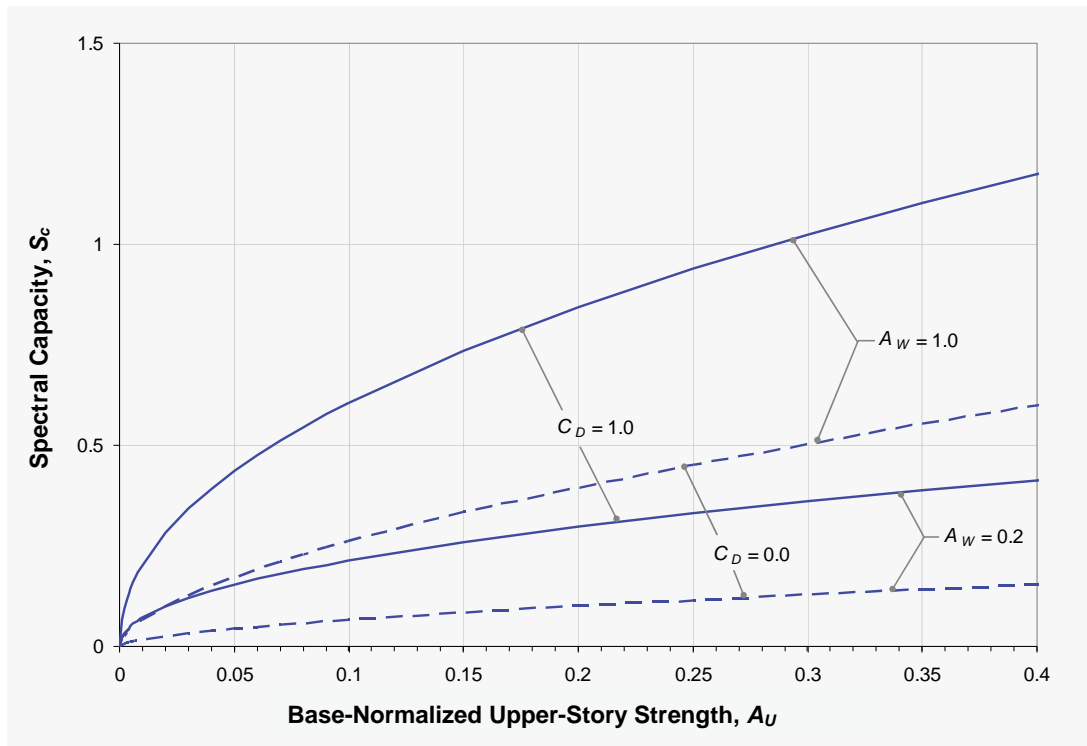

Figure 5-2 Plot showing variation in spectral acceleration capacity (spectral capacity) as a function of different existing building characteristics, i.e., different strength degradation ratios (C_D) and different weak-story ratios (A_W) ($POE = 20\%$, $C_T = 0.0$, $Q_s = 1.0$).

acceleration at which the structure fails the drift criteria. Away from the median, values on the fragility curve are functions of uncertainties in the surrogate models, represented by the standard deviation, β , of the log-normal curve. The values selected for β are 0.5 and 0.6 for $C_D = 1.0$ and 0.0, respectively. For these values, the tabulated drift limit *POE* adjustment

factors give points on the fragility curve relative to the median capacity. The lower the targeted drift limit *POE*, the lower the spectral acceleration capacity.

For example, consider a targeted drift limit *POE* of 20 percent. This represents a fairly conservative objective, seeking 80-percent confidence that the drift limits will not be exceeded under the specified shaking. The table of drift limit *POE* adjustment factors shows that the spectral acceleration capacity will be a bit less than two-thirds of the median capacity. This does not mean that the structure is actually weaker because higher confidence is sought. Rather, it means that the only way there will be an 80-percent chance of staying under the drift limits is if the demand is lower than this reduced value. That is, if you want high confidence, you need to assume a capacity lower than what it probably is. Of course, as you evaluate to a higher-confidence (lower drift limit *POE*) objective, it becomes more difficult to pass the evaluation, as shown in Section 5.4.

As discussed in Sections 1.4 and 2.3.2, the appropriate drift limit probability of exceedance (*POE*) can vary. For voluntary work, a target *POE* can be set, or the actual *POE* can be derived by working the equations backward (see Section 5.4.2). For a mandatory or incentivized program, the targeted drift limit *POE* will generally be given as a matter of policy. For work triggered by a building code, it is important to use the *POE* that most closely reflects the intent of the code.

5.4 Evaluate the Existing Structure

5.4.1 Compare the Spectral Acceleration Capacity with Site-Specific Demand

To represent seismic demand, the *Guidelines* use the short-period spectral acceleration corresponding to the site-specific Maximum Considered Earthquake (MCE), S_{MS} , as defined by ASCE/SEI 7-05 (ASCE, 2006a, Section 11.4.3)—the default hazard level of the *Guidelines*. The structure is deemed to satisfy the evaluation objective if Equation 5-6 is satisfied in both directions.

$$S_c \geq S_{MS} \quad (5-6)$$

Where Equation 5-6 is not satisfied, retrofit is required.

The short-period spectral acceleration corresponds to a fundamental period of 0.2 seconds. Many soft- or weak-story wood-frame buildings have periods longer than 0.2 seconds, especially when responding beyond their elastic range. Nevertheless, the short-period spectral value is to be used as the

demand of interest. The reason is not because it best represents the response of an actual building, but because it provides the most consistent and straightforward basis for comparing the actual building to the surrogate analyses.

Equation 5-6 uses S_{MS} because it corresponds to the *Guidelines*' default (embedded) performance objective. As discussed in Sections 1.4 and 2.3.2, however, a performance objective could use a different level of shaking, resulting in a higher or lower demand. In such cases, the short-period spectral acceleration of the selected shaking level should be used in place of S_{MS} .

5.4.2 Calculating the Probability of Exceedance

Where a drift limit *POE* value is set in advance of the evaluation, as in the case of most triggered or mandatory work, the evaluation focuses on whether the existing structure can meet the corresponding performance objective. *Guidelines* Section 5.4.1 addresses that question.

In other cases, where the drift limit *POE* is not specified, it can be useful to think of the evaluation from a different perspective. That is, given the median spectral acceleration capacity, S_{μ} , and the demand, S_{MS} , what confidence do they provide that drifts will remain below the critical levels? This question is of interest to voluntary projects where the decision to retrofit, or the scope of retrofit, depends on an owner's individual risk tolerance. It is also potentially valuable to a phased mandatory mitigation program of the sort described in Appendix B.

In general, the drift limit *POE* can be estimated by trial and error using the equations in Section 5.3, iterating on the value of *POE* until the spectral acceleration capacity just matches the demand. For a broad range of drift limit *POE* values, however, the relationship of the drift limit probability of exceedance (*POE*) adjustment factors to *POE* is very nearly linear and can therefore be estimated closely with closed-form linear equations.

If the ratio S_{MS}/S_{μ} is between 0.5 and 1.25, the drift limit *POE* may be estimated in each principal direction using Equations 5-7 and 5-8. Linear interpolation may be used for intermediate values of C_D . The two equations should be used to calculate drift limit *POE* (%) separately for each principal direction, x and y . The drift limit *POE* of the building is then taken as the minimum of the two directional values. If the value of drift limit *POE* computed this way is between 5% and 70%, the estimate is valid based on the assumed linear fit.

$$POE = 84.0 \left(\frac{S_{MS}}{S_{\mu}} - 0.41 \right), \text{ for } C_D = 1.0 \quad (5-7)$$

$$POE = 75.2 \left(\frac{S_{MS}}{S_{\mu}} - 0.33 \right), \text{ for } C_D = 0.0 \quad (5-8)$$

This chapter presents the measures that comprise a complete retrofit in accordance with the *Guidelines*. Figure 6-1 illustrates the content of the chapter and its relationship to other *Guidelines* chapters.

6.1 Retrofit Scope

In these *Guidelines*, retrofit to satisfy the selected performance objective involves all of the following measures in accordance with this chapter and with other codes or standards, as referenced:

- Addition or replacement of vertical elements of the seismic force-resisting system to increase first-story strength and reduce torsion (Sections 6.2 and 6.3);
- Providing new or replacement elements as needed to satisfy the eligibility rules in *Guidelines* Section 2.6 (Section 6.3.2);
- Detailing of any new, replacement, and enhanced vertical elements of the seismic force-resisting system (Section 6.5);
- Checking or providing detailed load path elements from the diaphragm immediately above the retrofitted story to the supporting ground (Section 6.5.1);
- Checking or strengthening of the diaphragm immediately above the retrofitted story (Section 6.5.2); and
- Providing new or replacement elements as needed to satisfy the condition assessment provisions in *Guidelines* Section 4.3.

Note that diaphragms, foundations, load path elements, deterioration, and construction defects were exempt from explicit evaluation in Chapter 5. If retrofit is performed, however, these items should be included in the scope where they would affect the intended performance of the retrofit. The purpose of evaluation under the *Guidelines* is to find dominant weak-story and open-front conditions. Where those are present, these other deficiencies are secondary. Where retrofit is being performed to remove the dominant deficiencies, however, the secondary deficiencies become significant and should be addressed to ensure completeness with respect to the performance objective.

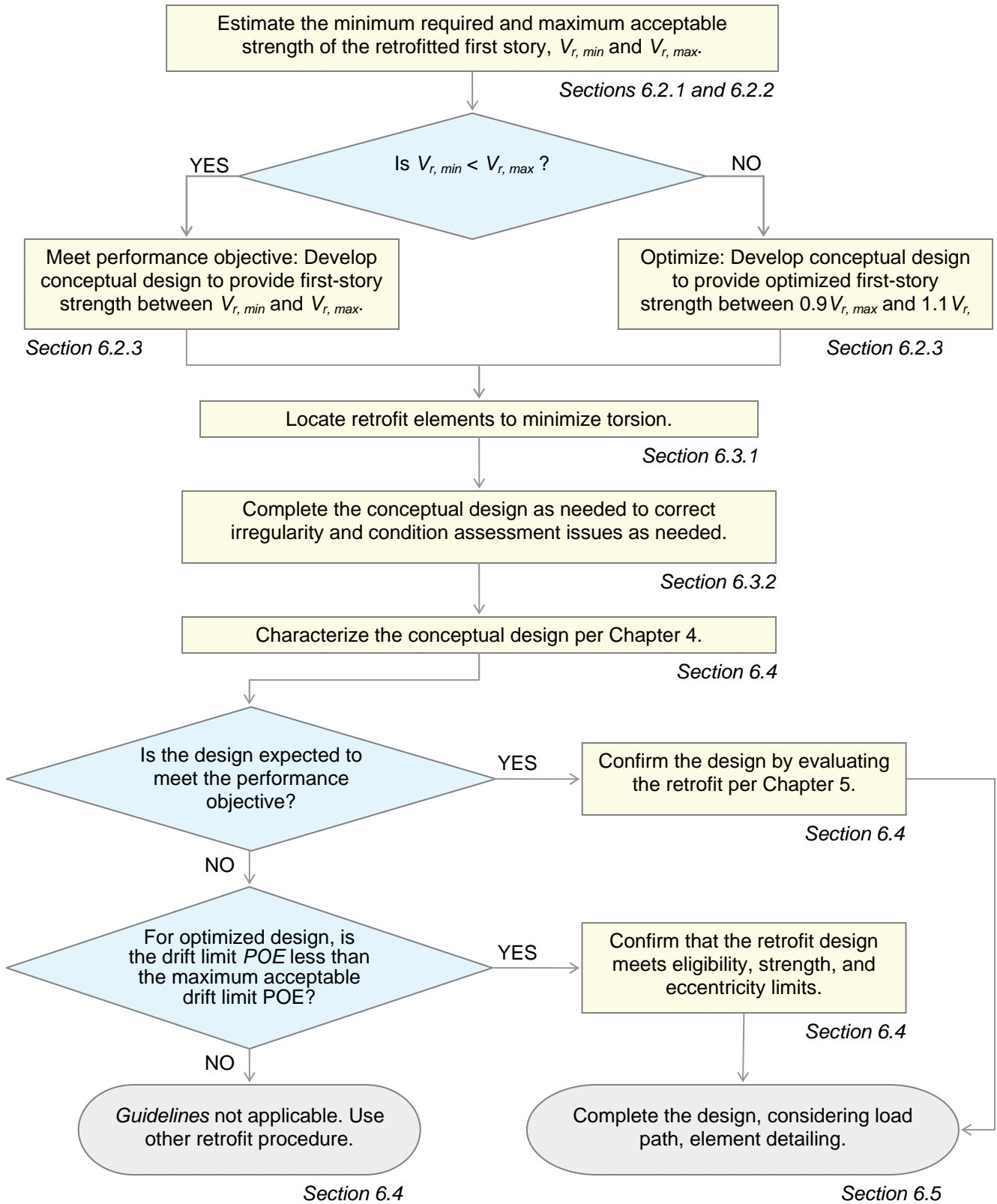

Figure 6-1 Flowchart of typical retrofit procedure.

6.2 Retrofit Strength

As shown in Chapter 5, existing buildings that do not satisfy the performance objective generally fail because of inadequate first-story strength (though torsion can play a significant role as well). This section discusses the *Guidelines*' approach to bounding and optimizing the strength of a retrofitted first story. Ultimately, however, a proposed retrofit design is assessed not by the estimating equations provided here, but by evaluating that design with the procedures in Chapter 5.

As discussed in Section 2.5.1, the *Guidelines* attempt to balance structural benefit with project cost by stipulating that retrofit work be limited to the first story. An ideal retrofit under the *Guidelines* would meet the performance objective with a first-story-only retrofit. As shown in this section, however, the ideal is sometimes not possible. In certain buildings, the retrofit needed to limit drifts in the first story would over-strengthen the first story, forcing upper stories to exceed *their* drift limits.

In these cases, the *Guidelines* offer the option of an optimized retrofit that reduces torsion and adds as much strength as possible to the first story, maximizing spectral acceleration capacity, without causing excessive drifts in upper stories. This solution gives the maximum confidence of not exceeding the drift limits while maintaining the feasibility of a first-story retrofit. Whether this optimized retrofit would provide acceptable performance remains a question for the owner or the jurisdiction. See Sections 6.2.3 and 6.4.2.

Most “weak-link” retrofit methodologies set the minimum scope necessary to mitigate a dominant deficiency, leaving the impression that anything more than the minimum is necessarily better. The *Guidelines* take a more complete approach; they consider not only the minimum retrofit strength, but also the potentially adverse effects of providing too much retrofit strength.

Section 6.2 of the *Guidelines* provides the means to estimate the minimum and maximum story strengths that will satisfy a given performance objective:

- The minimum required strength of the retrofitted first story is the minimum strength needed to meet the specified performance objective, considering only first-story drifts. It is estimated (Section 6.2.1) from regression relations similar to those used to evaluate the existing structure in Chapter 5.
- The maximum acceptable strength of the retrofitted first story is the strength at which upper-story drift becomes more critical than first-story

drift, given the performance objective. It is estimated (Section 6.2.2) with an empirical formula derived from the results of surrogate analyses.

In other words, the minimum and maximum strengths correspond to the two-part drift criteria embedded in the fragility definition. The minimum strength is set by the need to improve the first story. The maximum strength is set by the need to protect the un-retrofitted upper stories.

If the minimum required strength is less than the maximum acceptable strength, then any value between them will satisfy the performance objective. Within this range, lower values represent lower retrofit costs, and higher values represent better performance and higher confidence against unacceptable drifts.

If the minimum required strength is greater than the maximum acceptable strength, then it is unlikely that any first-story-only retrofit will satisfy the performance objective. In this case, the *Guidelines* provide the option to use the maximum acceptable strength as the basis for retrofitting the first story. This is the optimized retrofit, though the resulting drift limit probability of exceedance (*POE*) will exceed the targeted drift limit *POE* of the performance objective.

In either case, the equations below merely estimate the minimum and maximum values. This is because the design process is iterative and because the equations are empirical. Therefore, in either case, the *Guidelines* call for evaluating a proposed retrofit using the methodology of Chapters 4 and 5 to confirm an acceptable spectral acceleration capacity or, in the case of an optimized retrofit, to determine the resulting drift limit *POE*.

6.2.1 Estimated Minimum Required Strength of the Retrofitted First Story

The estimated minimum required strength of the retrofitted first story, $V_{r,min}$, is the total first-story strength (that is, existing strength plus retrofit strength) needed to satisfy the performance objective, considering only first-story drifts. Equations 6-1 through 6-5 incorporate the *Guidelines*' default (embedded) performance objective, which combines a targeted drift limit *POE*, story drifts at the onset of strength loss, and the spectral acceleration demand S_{MS} . (See Section 2.3 for discussion of performance objectives; Chapter 7 provides the means to account for different drift limits.) $V_{r,min}$, which is to be calculated in each direction, is derived from the surrogate analyses, much like the evaluation equations in Chapter 5.

$$V_{r,\min} = \frac{S_{MS} - X_2 C_D^3 - Y_2 (1 - C_D^3)}{X_1 C_D^3 + Y_1 (1 - C_D^3)} V_U \quad (6-1)$$

where:

$$X_0 = \alpha_{POE,1} A_U^{0.48} Q_s (1 - 0.5 C_T) \quad (6-2)$$

$$X_1 = 2.24 X_0 \text{ and } X_2 = 0.525 X_0 \quad (6-3)$$

$$Y_0 = \alpha_{POE,0} A_U^{0.6} Q_s (1 - 0.5 C_T) \quad (6-4)$$

$$Y_1 = 1.59 Y_0 \text{ and } Y_2 = 0.122 Y_0 \quad (6-5)$$

and where V_U is the controlling strength of the upper stories, A_U is the base-normalized upper-story strength as defined in Section 4.7.2, Q_s is the story height factor as defined in Section 4.7.6, $\alpha_{POE,1}$ and $\alpha_{POE,0}$ are the drift limit probability of exceedance (POE) adjustment factors as described in Section 5.3, and the strength degradation ratio, C_D , and the torsion coefficient, C_T , are determined as described below.

In applying Equations 6-1 through 6-5, values of C_D and C_T for the pre-retrofit structure may be used. These values will give an initial estimate of the minimum required strength. When retrofit elements are added, however, the values of these parameters will tend to change, reflecting the improved ductility and torsional strength of the retrofitted structure, so the value given by Equation 6-1 will change as well. (Appendix C provides an example of a building for which improved C_D and C_T values made a significant difference, allowing the retrofit design to achieve the performance objective without the need for optimized design.) One or two iterations are expected to result in a final estimate of the minimum required strength, but such a refined estimate is not really needed. Even the initial estimate might be enough to guide the retrofit design. Final acceptability of any retrofit design will be based on evaluation of its spectral acceleration capacity (Section 6.4), not on its relation to the estimated minimum strength. Alternatively, to arrive at an estimate with less iteration, one may guess at final values of C_D and C_T for use in Equations 6-1 through 6-5. In either case, the final design will be confirmed in the same manner. Note that the Weak-Story Tool (Section 1.6) automatically recalculates these values as retrofit elements are added to the model, eliminating much of the burden of iteration.

6.2.2 *Estimated Maximum Acceptable Strength of the Retrofitted First Story*

As shown by the grey curves in Figure 6-2, varying the first-story retrofit strength changes the spectral acceleration capacity. The different sets of

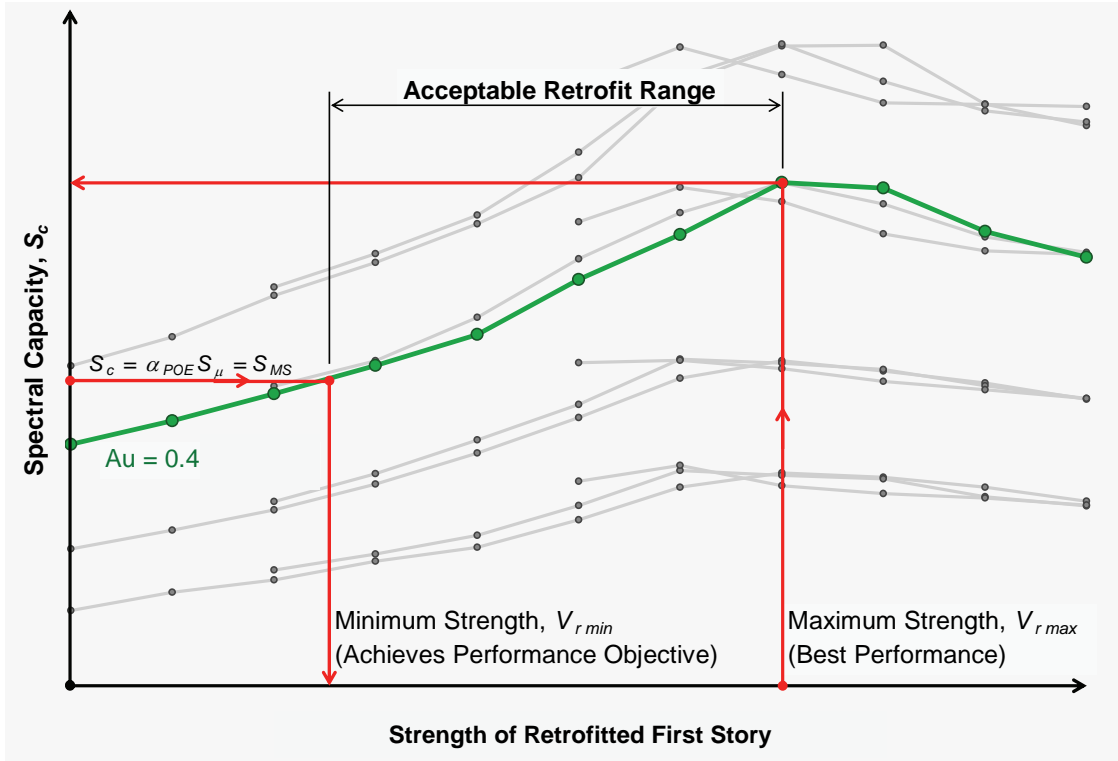

Figure 6-2 Plot of spectral acceleration capacity (spectral capacity) versus strength of retrofitted first-story, for buildings with strong upper stories. Grey lines show how varying the first-story retrofit strength changes the spectral acceleration capacity for different combinations of base-normalized upper-story strength, A_U , and weak story ratio, A_W . S_c is spectral acceleration capacity, and S_{MS} is short-period spectral acceleration demand.

curves represent different values of base-normalized upper-story strength, A_U . Within each set, separate curves represent different initial, unretrofitted values of the weak story ratio, A_W . Subsequent points along each curve represent changes in A_W due to different retrofits. These curves were derived from the fragility curves associated with the surrogate models—fragility curves that consider the possibility of excessive drift in either the first story or an upper story. The peak in each curve represents the point at which the response shifts from a first-story failure (left of the peak) to an upper-story failure (right of the peak). The peak, then, represents the maximum strength retrofit, that is, the retrofit that adds the most strength without inducing unacceptable drift in the upper stories.

The precise location of the peak varies with different values of A_U and initial A_W . Equation 6-6 approximates this point for a broad range of combinations, giving $V_{r,max}$, the total retrofitted strength (that is, the combined strength of existing and new elements).

$$V_{r,max} = (0.11A_U + 1.22) \cdot V_U \quad (6-6)$$

where A_U and V_U are defined above.

Since A_U and V_U are independent of first-story conditions, $V_{r,max}$ does not change as a retrofit design goes through iterations. Nevertheless, it is still an estimate because Equation 6-6 is a simple, but reasonable, linear fit through data with various values of C_D , as discussed further in Appendix E. Note that for typical buildings, A_U is less than 0.5, so the maximum acceptable strength of the first story, assuming the default (embedded) performance objective, will generally be between 1.2 and 1.3 times V_U . In other words, when the first story is more than about 1.3 times the strength of a brittle upper story, initial failure in the upper story controls performance.

6.2.3 Estimated Ranges of Acceptable Retrofit Strength

In buildings with sufficiently strong upper stories, $V_{r,max}$ will be greater than $V_{r,min}$, and either value, as well as any strength value between them, should satisfy the performance objective. This is illustrated in Figure 6-2. Each curve in the figure represents a building with C_T equal to 0.0 and Q_s equal to 1.0, evaluated to the default (embedded) performance objective with a drift limit *POE* at 20 percent. The dark curve represents an existing building with a relatively high base-normalized upper-story strength, A_U , of 0.4. At the left end of the dark curve, the weak-story ratio, A_W , is 0.6. Moving to the right, adding retrofit strength to the first story increases spectral acceleration capacity, and where the retrofitted strength reaches $V_{r,min}$, the spectral acceleration capacity, S_c , equals the spectral acceleration demand, S_{MS} , indicating the minimum retrofit that meets the default performance objective. As more retrofit strength is added, the spectral acceleration capacity continues to increase until it reaches a peak at roughly $V_{r,max}$. Increasing the first-story strength beyond $V_{r,max}$ would lead to unacceptable drift and related damage in one or more upper stories.

In buildings with weak upper stories, however, even the minimum required first-story strength will be beyond the peak of the curve. This is illustrated in Figure 6-3. The dark curve represents another existing building, but this time with a low base-normalized upper-story strength, A_U , of 0.1. In this case, the spectral acceleration capacity again increases as retrofit strength is added, but it reaches its peak before the minimum required strength is obtained. A spectral acceleration capacity equal to the spectral acceleration demand would only be achievable if the upper stories did not begin to control the response, as suggested by the dotted line. Thus, $V_{r,max}$, representing the peak of the dark curve, turns out to be less than $V_{r,min}$, at the far right edge of the figure. In this case, no first-story-only retrofit will satisfy the performance objective. Instead, an owner or jurisdiction might consider either:

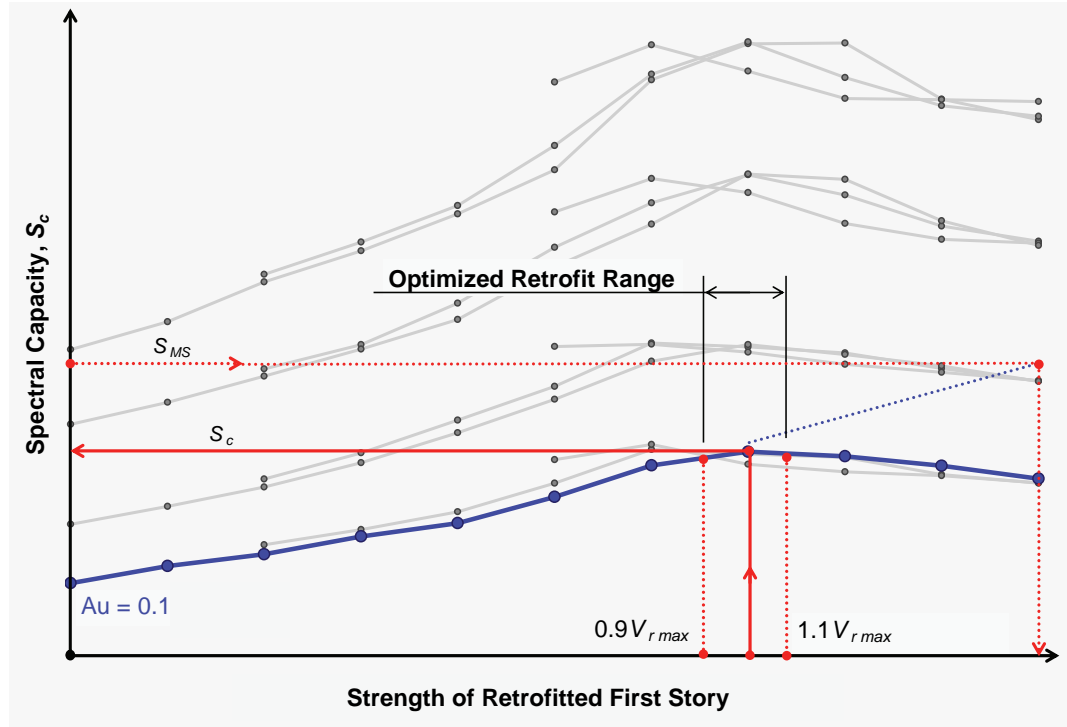

Figure 6-3 Plot of spectral acceleration capacity (spectral capacity) versus strength of retrofitted first-story, for buildings with weak upper stories. Grey lines show how varying the first-story retrofit strength changes the spectral acceleration capacity for different combinations of base-normalized upper-story strength, A_{Uj} , and weak story ratio, A_{Wj} . S_c is spectral acceleration capacity, and S_{MS} is short-period spectral acceleration demand.

- An optimized first-story-only retrofit that maximizes the spectral acceleration capacity by providing a first-story strength roughly equal to $V_{r,max}$. Such a solution would not meet the performance objective but would make the most of a first-story-only retrofit.
- A retrofit scheme that strengthens one or more upper stories as well as the first story, as needed to meet the performance objective. Such a full-building solution would be outside the scope of the *Guidelines*.

The *Guidelines*, which are premised on the idea of practical, cost-effective mitigation, recognize the value of the latter approach involving optimized retrofit. While the decision to waive the performance objective and accept such retrofits is ultimately a policy decision for the owner or jurisdiction, it is the judgment of the *Guidelines*' writers that if the optimized retrofit would provide a significant measure of improvement (see Section 6.4.2), it could be an appropriate solution for many mitigation projects and programs. In particular, if the alternative—a full building retrofit—would prove so costly and disruptive as to make the mitigation program infeasible, then optimized

first-story retrofit seems the better choice. On the other hand, if consistency with the performance objective is crucial, then optimized first-story retrofits might be unsuitable.

Importantly, Figure 6-3 also illustrates the ineffectiveness of overly strong first-story-only retrofits. Beyond the peak at $V_{r,max}$, additional first-story strength does not bring a structure with weak upper stories any closer to meeting the performance objective. More strength merely adds cost to the retrofit project with no benefit. In fact, if enough strength is added, the spectral acceleration capacity decreases. It is this effect that a simplified retrofit code such as IEBC Chapter A4 can miss.

Where optimized retrofit is pursued, the basis for the first-story retrofit strength is $V_{r,max}$. As Figures 6-2 and 6-3 show, the peak of each curve is relatively flat, so that similar performance can be expected for a range of strengths around $V_{r,max}$. With this in mind, and to provide the designer with some flexibility in sizing retrofit elements, the *Guidelines* recommend that the acceptable range of first-story retrofit strength, V_{1r} , should be such that Equation 6-7 is satisfied.

$$0.9V_{r,max} \leq V_{1r} \leq 1.1V_{r,max} \quad (6-7)$$

In addition to satisfying Equation 6-7, an optimized retrofit should also locate the retrofit elements so as to minimize torsion, as discussed in Section 6.3.1.

Each principal direction should be considered separately when estimating the ranges of acceptable retrofit strength. It is possible that one direction will have strong enough upper-story walls to meet the performance objective, while the other direction will qualify only for an optimized design. Whichever combination applies, however, the effect of the two solutions acting together can affect the structure's torsional response and must be confirmed, per Section 6.4.

6.3 Locating Retrofit Elements

The best performance will generally be achieved where retrofit elements are located in plan so as to minimize first-story torsion. This is especially important for optimized designs. In addition, eligibility for the *Guidelines'* methodology (per Section 2.6) requires the mitigation of certain diaphragm irregularities, and retrofit elements may be located for this purpose as well.

6.3.1 Retrofit Element Location to Minimize Torsion

Where the retrofit satisfies the performance objective, the spectral acceleration capacity already accounts approximately (through the C_T factor) for first-story eccentricities and torsion. Therefore, an explicit requirement to locate retrofit elements so as to minimize torsion is not necessary. Still, as the spectral acceleration capacity equations reflect, there are advantages to reducing torsion by design. Retrofits that minimize torsion achieve a higher capacity with the same amount of material (and cost), or can achieve the minimum required capacity with less material.

For optimized retrofits that, by definition, do not satisfy the targeted performance objective, potential torsion must be addressed more explicitly, for two related reasons. First, the optimized strength is only truly optimized when the added retrofit elements minimize torsion. If the only requirement for optimized retrofit were to satisfy Equation 6-7, any arrangement of the retrofit elements would be satisfactory. But as the spectral acceleration capacity equations show, if torsion is minimized, a lower, optimized drift limit *POE* can be achieved for the same retrofit strength. Second, the empirical grey curves in Figures 6-2 and 6-3 were derived from surrogate models that assumed no torsion. Therefore, to best match the *Guidelines'* assumptions, optimized retrofits should minimize torsion.

As shown in Section 4.6, first-story torsion is a function of the eccentricity between the centers of strength of the first and second stories. When retrofit elements are added, the first-story center of strength can shift, so x and y components of the eccentricity of the retrofitted first story, $e_{r,x}$ and $e_{r,y}$, become:

$$e_{r,x} = |COS_{2,x} - COS_{1r,x}| \quad (6-8)$$

$$e_{r,y} = |COS_{2,y} - COS_{1r,y}| \quad (6-9)$$

where:

$COS_{1r,x}$ = x coordinate of the center of strength of the retrofitted first story, calculated in accordance with Section 4.6.4,

$COS_{2,x}$ = x coordinate of the center of strength of the second story, calculated in accordance with Section 4.6.4,

$COS_{1r,y}$ = y coordinate of the center of strength of the retrofitted first story, calculated in accordance with Section 4.6.4, and

$COS_{2,y}$ = y coordinate of the center of strength of the second story, calculated in accordance with Section 4.6.4.

Potential torsion is minimized when the eccentricity is zero, so ideally, retrofit elements should be located so that both $e_{r,x}$ and $e_{r,y}$ are zero. Where the pre-retrofit eccentricity is large and the retrofit strength is limited by Equation 6-7, however, it might not be possible to eliminate the eccentricity completely—the retrofit elements would have to be located, theoretically, outside the building footprint. In this case, the perimeter of the building becomes the optimal location. But even then, retrofit elements cannot always be placed at the perimeter because of interference with existing utilities, egress ways, property lines, and other conditions. Therefore, to provide design flexibility and to reflect the *Guidelines*' overall preference for feasible, cost-effective solutions, the logic of locating retrofit elements should work as follows:

- Where possible, locate the retrofit elements so that $e_{r,x}$ and $e_{r,y}$ are zero. For design flexibility, $e_{r,x}$ is acceptable if it is less than 10 percent of the building dimension L_x (and similarly in the y direction).
- Where the foregoing rule cannot be satisfied, locate the retrofit elements along the perimeter lines that minimize $e_{r,x}$ and $e_{r,y}$. For design flexibility, new retrofit elements are acceptable if they are a distance from the appropriate perimeter line less than 5 percent of the corresponding building dimension.

There might be cases where all the necessary retrofit elements cannot be made to fit along a single perimeter wall line. In these cases, the design should follow the general rule and try to minimize eccentricity. If the remaining eccentricity still allows significant torsion and significantly limits the reduction in drift limit *POE*, the building official and engineer of record should consider whether the *Guidelines* methodology, which presumes minimal torsion for optimized retrofits, is really suitable to the building in question.

Achieving the optimized story strength is more important than achieving the minimum eccentricity. Therefore, even if the eccentricity can be eliminated by adding more or stronger retrofit elements, that approach should not be taken if it increases the retrofitted first-story strength beyond the limit of Equation 6-7.

6.3.2 Retrofit Element Location to Ensure Eligibility

The *Guidelines* apply only to buildings—existing or retrofitted—that meet the eligibility criteria in Section 2.6, including the limits on diaphragm shape and plan irregularity in Section 2.6.4. As stipulated there, an ineligible

existing building may be made eligible through retrofit measures that divide the diaphragm into eligible pieces with qualifying walls or frames.

Figure 6-4 shows a diaphragm whose aspect ratio exceeds the limit of 2:1 (from Section 2.6.4). Following the provision in Section 2.6.4, the building can be made eligible by placing a qualifying wall or frame element to reduce the diaphragm span as shown.

Figures 6-5 and 6-6 show a building with an ineligible re-entrant corner. Following the provisions of Section 2.6.4, as shown in the figures, the building can be made eligible if qualifying existing or new wall or frame lines divide the diaphragm so that each diaphragm section, D_1 or D_2 , has an aspect ratio less than 2:1. (In the Figure 6-5 and 6-6 examples, the cantilever limit does not apply because each extension of the diaphragm beyond the re-entrant corner has a qualifying wall section at its edge and is therefore not cantilevered.)

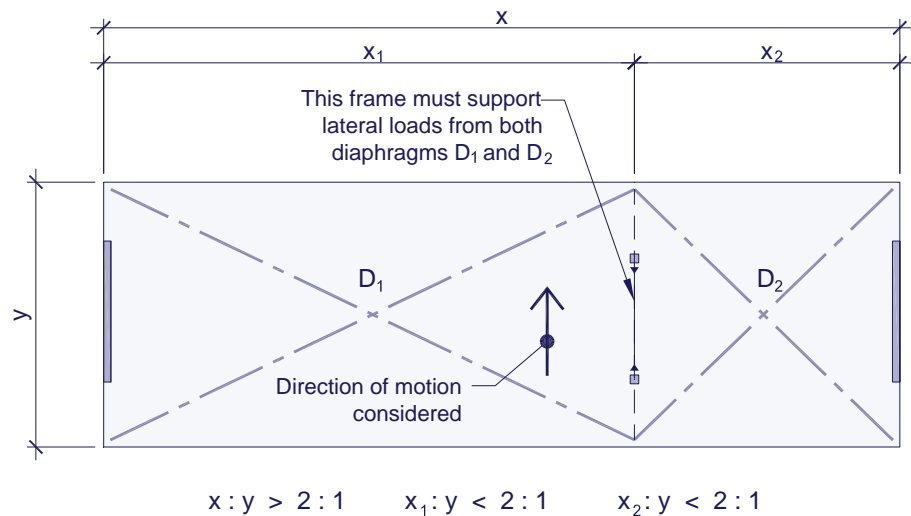

Figure 6-4 Floor plan schematic showing use of retrofit elements to meet diaphragm aspect ratio limits. The retrofit element between diaphragm D_1 and D_2 must be a qualifying wall or frame per Section 2.6.4.

6.4 Confirmed Performance of the Retrofitted Structure

While the equations in Section 6.2 estimate the range of acceptable retrofit strength, a final retrofit design is assessed by evaluating it with the procedures in Chapters 4 and 5.

For this evaluation, the parameters A_w , C_D , C_T , and related parameters should be recalculated for the proposed retrofit design, in each direction. The parameter A_U (base-normalized upper-story strength) is not affected by the first-story-only retrofit. Note that the sizing and location of key elements in a

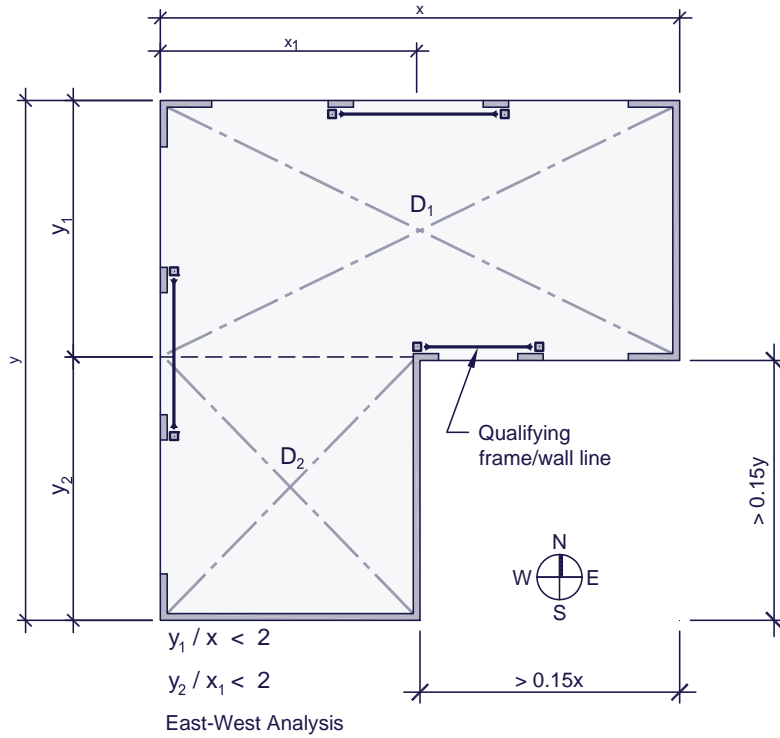

Figure 6-5 Floor plan schematic showing use of retrofit elements to satisfy re-entrant corner limits, east-west analysis. D denotes diaphragm.

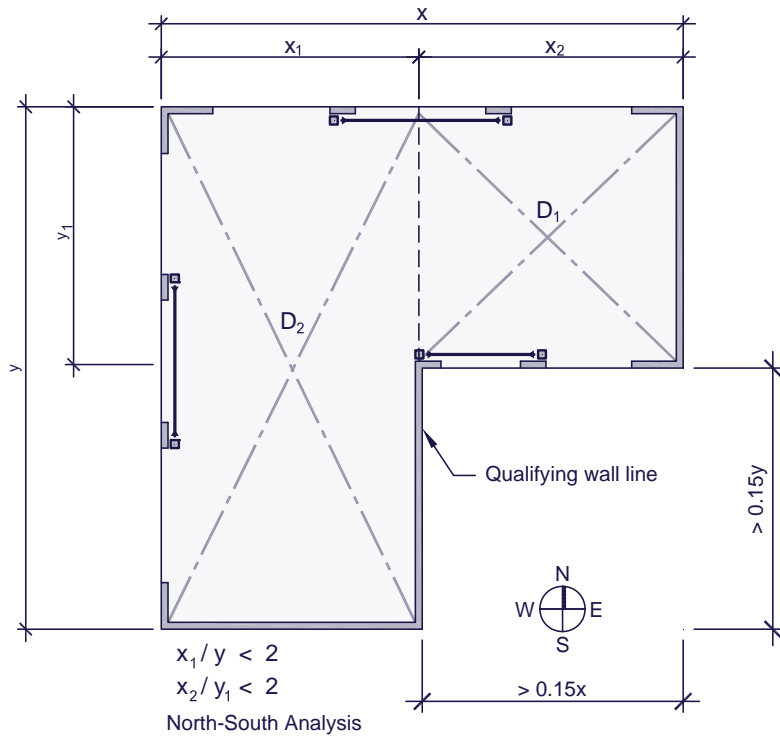

Figure 6-6 Floor plan schematic showing use of retrofit elements to satisfy re-entrant corner limits, north-south analysis. D denotes diaphragm.

final retrofit design must account not only for the necessary story strength, but also for any eligibility or condition assessment issues identified earlier in the process. Further, optimized retrofits should minimize torsion, as discussed in Section 6.3.1. The Weak Story Tool (Section 1.6 and Appendix A) can be helpful in these tasks.

6.4.1 Retrofits Intended to Satisfy the Performance Objective

If the retrofit is intended to satisfy the performance objective, the spectral acceleration capacity of the retrofitted structure should be determined and compared with the spectral acceleration demand per Sections 5.2 through 5.4. If the capacity exceeds the demand, the retrofit design is confirmed. (Alternatively, the drift limit probability of exceedance (*POE*) can be determined per Section 5.4.2 and compared with the targeted drift limit *POE* of the performance objective.)

6.4.2 Optimized Retrofits that Do Not Satisfy the Performance Objective

If the retrofit is intended to optimize performance but *not* necessarily satisfy the targeted performance objective, three checks should be made:

- 1 The peak story strength of the retrofitted first story, V_{I_r} , should be determined per Section 4.6.2 and shown to satisfy Equation 6-7.
- 2 The center of strength of the retrofitted first story, COS_{I_r} , should be determined per Section 4.6.4 and shown to satisfy the eccentricity limits in Section 6.3.1.
- 3 The drift limit probability of exceedance (*POE*) of the retrofitted structure should be determined per Section 5.4.2 and shown to be less than the maximum acceptable *POE* for optimized retrofits.

The “maximum acceptable drift limit *POE* for optimized retrofits” is a matter of owner or jurisdiction judgment. The optimized retrofit does not satisfy the performance objective in quantitative terms. The acceptability of an optimized retrofit is therefore not a function of performance alone, but one of costs and benefits, in which improved performance is compared with fully satisfactory performance and weighed against the costs of retrofitting.

To understand the issue, consider a performance objective that includes a targeted drift limit *POE* of 20 percent. Any retrofit that lowers the *POE* to 20 percent or less fully satisfies the objective. Now consider a case in which a first-story-only retrofit would lower the drift limit *POE* from 60 percent to 40 percent. Two questions arise: First, is 40 percent close enough to the targeted objective of 20 percent to ever be considered adequate, if not fully

compliant? Second, is the improvement from 60 to 40 worth the cost of retrofit?

Now consider a case in which a first-story-only retrofit would lower the drift limit *POE* from 90 percent to 40 percent. Even if 40 percent is still risky, the improvement is enormous and probably worthwhile, especially if the cost of getting all the way down to 20 percent with a full-building retrofit would make the project infeasible.

Owners undertaking voluntary work must weigh the costs and benefits of full-building and first-story-only retrofits. As discussed in Section 1.4.2 and Appendix B, a jurisdiction designing a mitigation program should select the maximum acceptable drift limit *POE* considering the overall goals of its program and the composition of its building stock.

It is clear, then, that the *Guidelines* cannot recommend a maximum acceptable drift limit *POE* that will apply in all cases. Nevertheless, it is the judgment of the *Guidelines*' writers that if a drift limit *POE* less than 50 percent cannot be achieved, it generally indicates extremely weak upper-story walls, and that fact argues strongly for a full-building retrofit.

If the building is such that the optimized first-story retrofit cannot provide a drift limit *POE* less than the maximum acceptable value, then the retrofit cannot be designed using the *Guidelines*. Instead, a more comprehensive or building-specific approach will be needed. The *Guidelines* recommend ASCE/SEI 41 as the basis for such a retrofit.

Importantly, the *Guidelines* recommend that IEBC Chapter A4 should *not* be used in these cases, since IEBC Chapter A4 makes some of the same assumptions as the *Guidelines*. In other words, if no acceptable retrofit can be found using the *Guidelines*, it is probably because the existing building is too weak in its upper stories for a first-story-only approach to work. Since IEBC Chapter A4 also stipulates a first-story-only approach, but does not explicitly check the upper stories as the *Guidelines* do, use of IEBC Chapter A4 could result in this weakness being overlooked, thereby providing a false sense of improvement.

6.5 Retrofit Element Selection and Design

For the *Guidelines*' methodology to be reliable, the retrofit design must be consistent with *Guidelines*' assumptions. Therefore, certain restrictions and design criteria apply to the selection of suitable retrofit elements.

The surrogate modeling on which the *Guidelines* are based assumes that retrofit elements will be ductile enough to qualify for the high-displacement capacity designation illustrated in Figure 4-1.

General guidelines for the design of retrofit elements, supplemented by material- and system-specific guidelines below, include:

- New retrofit wall elements should be sized based on the strengths given in Table 4-1. Where principal retrofit elements (walls and frames) are sized based on unit strengths from codes or standards, the full expected capacity, without strength reductions or resistance factors, should be used.
- The load-drift curve of each retrofit element type should be based on expected material properties, including overstrength. The full expected capacity, without strength reduction or resistance factors, should be assumed for purposes of establishing load-drift curves and peak strengths.
- Each retrofit element should be such that a load-drift curve based on similar elements alone would have a strength degradation ratio, C_D , greater than or equal to 0.8.
- The load-drift curve of each retrofit element type should be defined up to 5 percent interstory drift or as needed to fully characterize the retrofit design per Chapter 4.
- Materials and systems for retrofit elements should be consistent with provisions of the building code for new construction. While codes for existing buildings typically allow “like materials” for repairs and alterations (for example, see 2009 IBC Section 3401.4.2), the *Guidelines* presume that retrofit elements will be reliably ductile. This is consistent with code provisions for voluntary seismic upgrade (for example, see IBC Section 3404.5 or 2009 IEBC Section 707.6).
- Detailing of retrofit wall and frame elements should be consistent with that applied to special seismic-force-resisting systems used in new construction for the corresponding occupancy and risk category.
- Quality assurance measures should be applied. They should be consistent with those normally applied to special seismic-force resisting systems used in new construction for the corresponding occupancy and risk category.

6.5.1 Load Path Components

Reliable performance of retrofit elements relies on the presence of a designed and detailed load path from the second-floor diaphragm (or the diaphragm immediately above the retrofitted story) through the retrofit elements and their foundations, to the supporting soils. Load path elements should be designed to develop the full strength and the intended mechanism of the principal wall or frame elements. Therefore, to ensure reliability, appropriate strength reduction factors should be applied to the ultimate strengths of load path elements. Specific criteria may be derived from principles of capacity design or from other codes or standards, such as ASCE/SEI 41 or building code provisions involving the overstrength factor, Ω_0 .

New foundation elements should be provided as needed to resist bearing, sliding, and overturning forces associated with the retrofit element acting at its peak strength. Ultimate material and soil strengths should be used.

Connections and load path elements related to wall or frame overturning should not assume any acting dead load except for the self weight of the retrofit element (and its foundation, if adequately connected), unless the retrofit element incorporates existing gravity-load-carrying framing or unless the design and construction explicitly transfer existing dead load to the retrofit element.

6.5.2 Second-Floor Diaphragm

The second-floor diaphragm (or the diaphragm immediately above the retrofitted story) should be strengthened as needed to ensure that expected forces can be transferred between the diaphragm and the first-story elements. Diaphragm strengthening can sometimes be avoided by the careful placement of retrofit walls or frames.

6.5.3 Wood Structural Panel Shear Walls

Load-drift curves for retrofit designs employing wood structural panel shear walls may be based on *Guidelines* Sections 4.4 through 4.6. As noted in Section 4.5.3.1, however, the simplified overturning reduction factor should not be used for retrofit elements.

Existing shear walls may be modified by replacing existing sheathing materials with new wood structural panels or by adding new wood structural panels onto existing wall framing or assemblies.

6.5.4 Steel Moment Frames

Steel retrofit elements may be designed and detailed, with reference to ASCE/SEI 7 (ASCE, 2006a or later), either as Moment-Resisting Frame Systems or as Cantilevered Column Systems, as long as the element configuration provides the minimum C_D value of 0.8. Generally, retrofit elements that conform to the requirements of AISC 341-05 (AISC, 2005) Section 9 for Special Moment Frames or AISC 341-10 (AISC, 2011) for Special Cantilevered Column systems are most likely to meet this requirement. Intermediate and Ordinary systems are unlikely to do so, but the *Guidelines* do not specifically require, approve, or rule out any system. For complying systems, the load-drift curve may be approximated by the tri-linear curve shown in Figure 6-7, where Z_y and F_{ye} are properties of the yielding member.

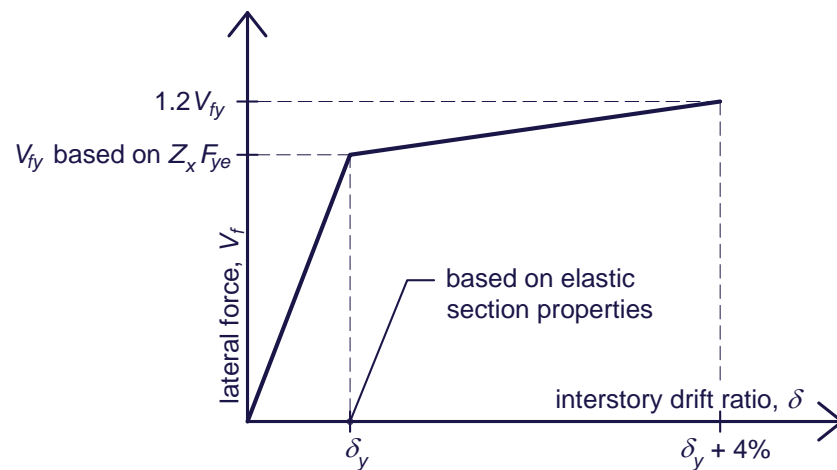

Figure 6-7 Simplified load-drift curve for steel Special Moment Frame retrofit elements. Z_y and F_{ye} are properties of the yielding member.

6.5.5 Steel Braced Frames

Concentrically braced frame elements, including Ordinary or Special Concentrically Braced Frames, are not suitable for retrofit using the *Guidelines*. These systems involve buckling braces and are not expected to satisfy the requirement for a C_D value of 0.8 with adequate reliability.

Buckling-restrained Braced Frames, however, are suitable, provided that the load-drift curve of such a frame can provide the minimum C_D value of 0.8. Frames that conform to the requirements of AISC 341-05 (AISC, 2005) Section 16 for Buckling-restrained Braced Frames are likely to meet this requirement. For such frames, the load-drift curve may be approximated by a tri-linear curve similar to that shown in Figure 6-7.

6.5.6 Concrete or Reinforced Masonry Shear Walls

Concrete or reinforced masonry shear walls are not suitable for retrofit using the *Guidelines*. While these systems are often adequately strong, their yield point and capacity are difficult to establish with precision, so they do not work well with the *Guidelines* methodology, which relies on predictable load-drift curves and limited first-story strength.

Alternative Performance Assessment

7.1 Purpose

As described in previous Chapters, any performance objective involves a desired performance level, which the *Guidelines* characterize in terms of interstory drift limits. The equations in Chapters 5 and 6 assume the *Guidelines'* default objective, using drift limits associated with the onset of strength loss. This Chapter provides alternative equations suitable for tighter drift limits that correspond to less damage.

7.2 Assessment Background

The assessment approach presented here is conceptually the same as that presented in Chapter 5. As discussed in Chapter 5, a large number of nonlinear response history analyses form the basis for the evaluation empirical equations. Any set of drift criteria may be selected to represent the seismic performance of interest. Using these drift criteria, the analytical results can be queried to define equations that relate a building's characteristics to its probability of exceeding the drift criteria at some earthquake intensity. This has been done for the two sets of drift criteria defined below. The building's characteristics are quantified by the coefficients presented in Chapter 4, and the earthquake shaking intensity is quantified as a specified short-period spectral acceleration, S_d .

7.3 Interstory Drift Limits

In this chapter, two sets of drift criteria are considered: “onset of strength loss” (*OSL*) and “onset of damage” (*OD*). Figure 7-1 illustrates a comparison of the drift criteria in the context of the two archetypal sheathing material backbone curves representing degradation ratios of zero and one. The *Guidelines* use a drift limit of 1.0 % for *OD* for all materials. As shown in Figure 7-1, 1% represents near the yield limit and peak strength for high deformability materials ($C_D = 1$), and is deemed to be close enough to the peak strength for low deformability materials ($C_D = 0$).

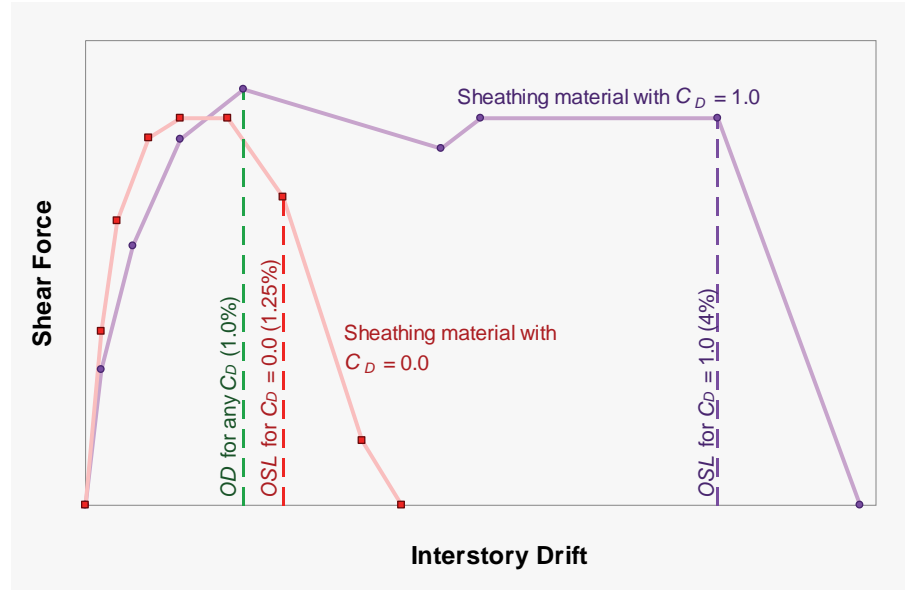

Figure 7-1 Illustration of drift limit definitions relative to two sheathing backbone curves with $C_D = 0.0$ and 1.0 , respectively.

7.4 Spectral Acceleration Capacity

Chapter 5 provides spectral acceleration capacity equations relative to the *OSL* drift criteria. The evaluation equation in Chapter 5 has the general form:

$$S_c = \alpha_{POE} (\alpha_U + \alpha_W A_{W,x}) (1 - 0.5C_T) Q_s A_{U,x}^{\gamma_U} \quad (7-1)$$

where the coefficients α_U , α_W , and γ_U are computed to minimize the error of the fit to the analytical results. These coefficients depend on the drift criteria and may be modified to fit the analytical results queried relative to other drift criteria. The coefficients γ_U , α_U , and α_W are tabulated in Table 7-1 for the *OSL* and *OD* drift limits.

Table 7-1 Curve-Fitting Coefficients (γ_U , α_U , and α_W) for Calculating Spectral Acceleration Capacity.

	γ_U	α_U	α_W
Strength Degradation Ratio, $C_D = 0.0$			
<i>OSL</i>	0.60	0.122	1.594
<i>OD</i>	0.60	0.044	1.551
Strength Degradation Ratio, $C_D = 1.0$			
<i>OSL</i>	0.48	0.525	2.240
<i>OD</i>	0.56	-0.027	1.537

Note: *OSL* and *OD* refer to the *Onset of Strength Loss* and *Onset of Damage* drift limits, respectively.

Thus, the spectral acceleration capacity for the drift criteria under consideration is given by:

$$S_{c1,x} = \alpha_{POE,1} S_{\mu1,x} \text{ for } C_D = 1.0 \quad (7-2)$$

$$S_{c0,x} = \alpha_{POE,0} S_{\mu0,x} \text{ for } C_D = 0.0 \quad (7-3)$$

$$S_{\mu1,x} = (\alpha_{U1} + \alpha_{W1} A_{W,x}) (1 - 0.5 C_T) Q_s A_{U,x}^{\gamma_{U1}} \text{ for } C_D = 1.0 \quad (7-4)$$

$$S_{\mu0,x} = (\alpha_{U0} + \alpha_{W0} A_{W,x}) (1 - 0.5 C_T) Q_s A_{U,x}^{\gamma_{U0}} \text{ for } C_D = 0.0 \quad (7-5)$$

$$S_c = C_D^3 S_{c1} + (1 - C_D^3) S_{c0} \quad (7-6)$$

where:

$S_{\mu1,x}$ = median spectral acceleration capacity in the x -direction for $C_D = 1.0$,

$S_{\mu0,x}$ = median spectral acceleration capacity in the x -direction for $C_D = 0.0$,

$S_{c1,x}$ = spectral acceleration capacity (adjusted for drift limit *POE*) in the x direction for $C_D = 1.0$,

$S_{c0,x}$ = spectral acceleration capacity (adjusted for drift limit *POE*) in the x direction for $C_D = 0.0$,

α_{POE} = drift limit *POE* adjustment factors defined in Chapter 5,

$S_{c,x}$ = spectral acceleration capacity in the x direction for intermediate values of C_D ,

γ_{U1} , α_{U1} , and α_{W1} are as tabulated in Table 7-1 for $C_D = 1.0$,

γ_{U0} , α_{U0} , and α_{W0} are as tabulated in Table 7-1 for $C_D = 0.0$, and

Q_s , story height factor, and A_U , base-normalized upper-story strength, are defined earlier.

Figures 7-2 through 7-5 show charts of median spectral acceleration capacity, S_{μ} , for various values of base-normalized upper-story strength, A_U , weak-story ratio, A_W , and strength degradation ratio, C_D , for the *OD* and *OSL* drift limits. The torsion coefficient, C_T is zero in all cases. The plots are graphical representations of Equation 7-4 and Equation 7-5 showing the analytical results to which the curves are fitted.

7.5 Estimating the Drift Limit Probability of Exceedance

The drift limit probability of exceedance (*POE*) may be estimated using the same procedure presented in Chapter 5 for the specified short-period spectral acceleration demand, S_d . If the ratio, S_d/S_{μ} is between 0.5 and 1.25, the drift

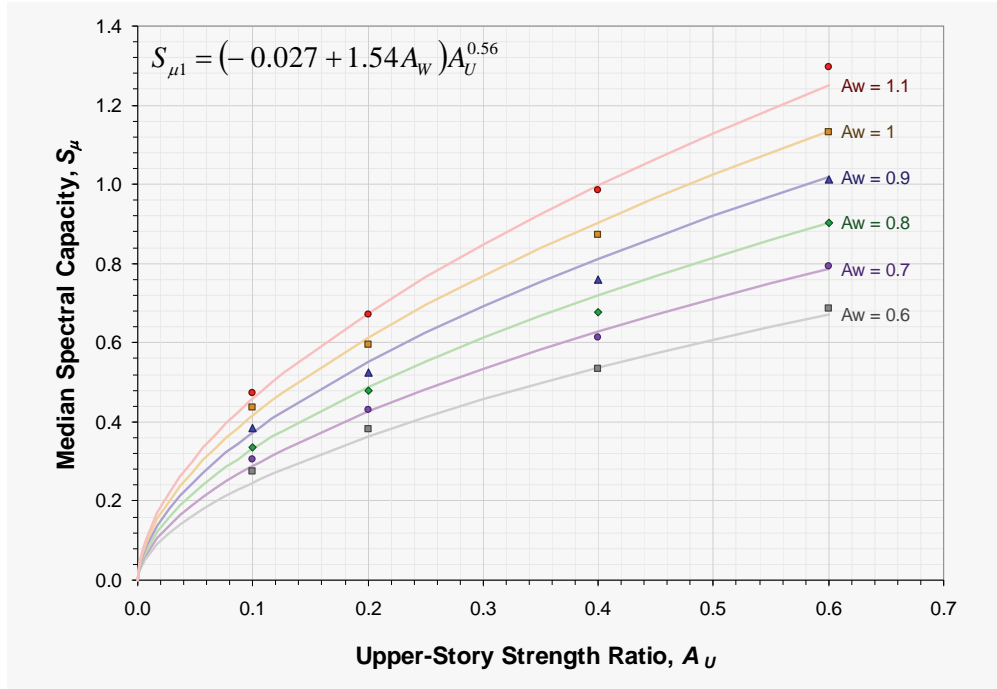

Figure 7-2 Curves showing the relationship between as-built median spectral acceleration capacity, S_{μ} and base-normalized upper-story strength for various weak-story ratios, A_W , and for the *Onset of Damage* set of drift limits. Strength degradation ratio $C_D = 1.0$.

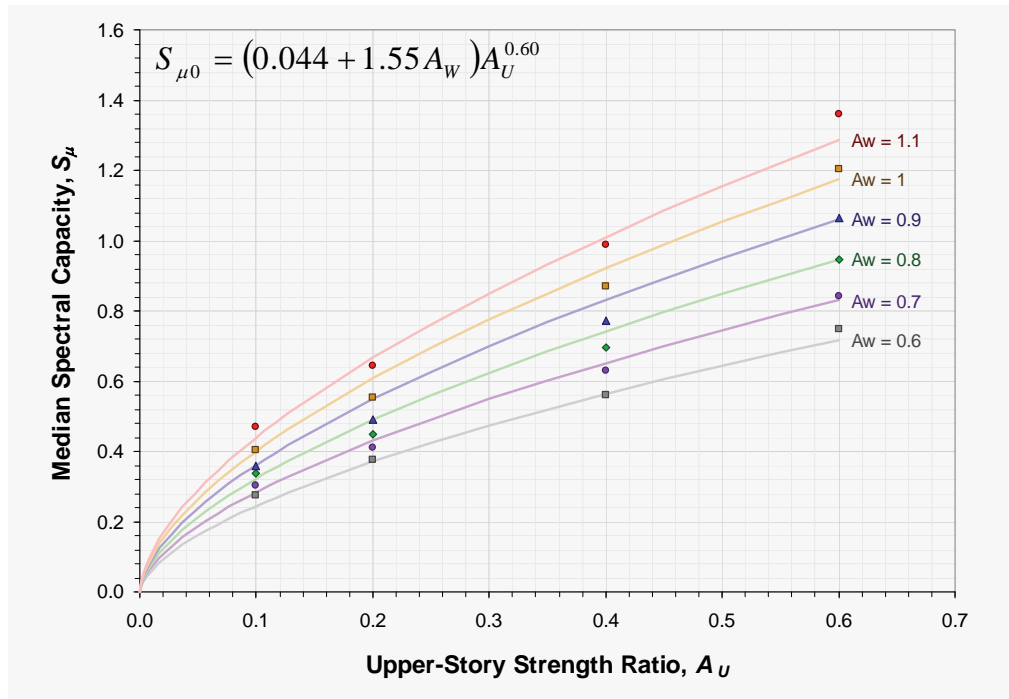

Figure 7-3 Curves showing the relationship between as-built median spectral acceleration capacity, S_{μ} and base-normalized upper-story strength for various weak-story ratios, A_W , and for the *Onset of Damage* set of drift limits. Strength degradation ratio $C_D = 0.0$.

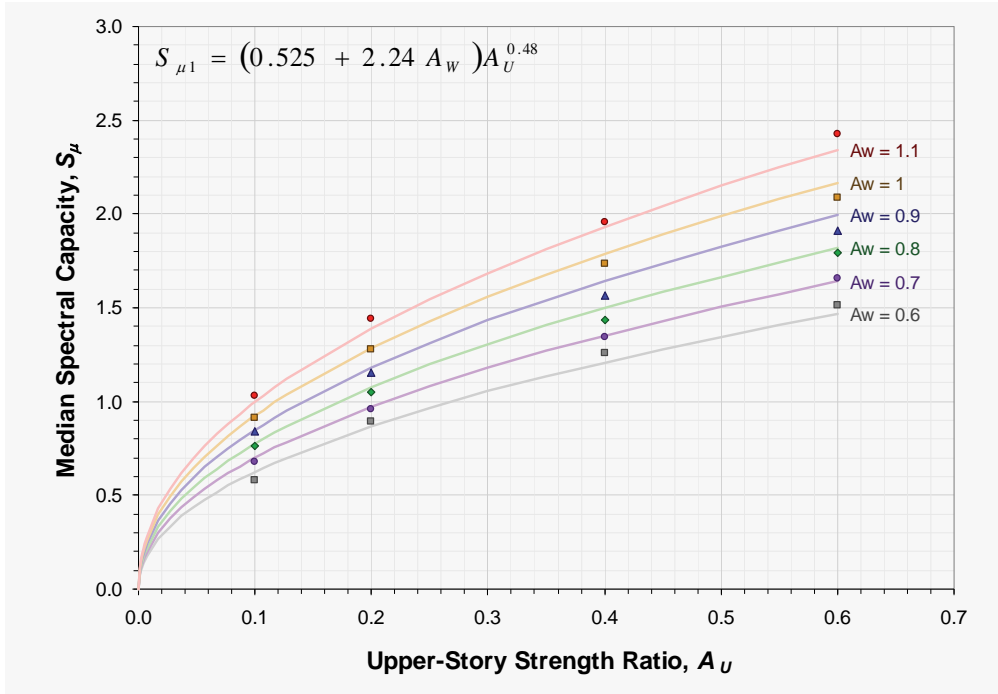

Figure 7-4 Curves showing the relationship between as-built median spectral acceleration capacity, S_{μ} , and base-normalized upper-story strength for various weak-story ratios, A_W , and for the *Onset of Strength Loss* set of drift limits. Strength degradation ratio $C_D = 1.0$.

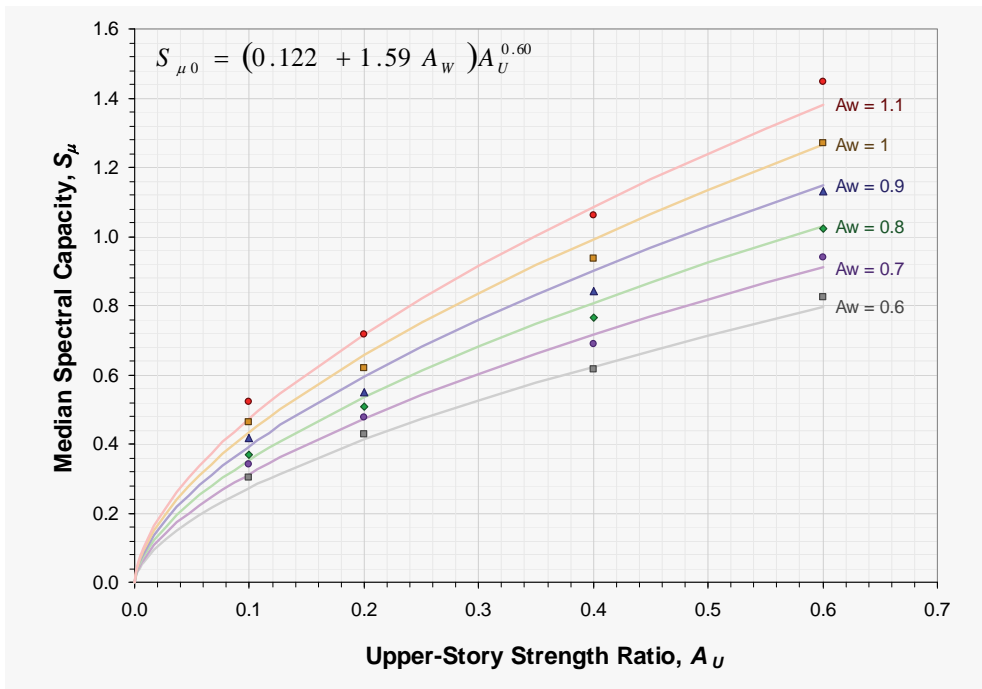

Figure 7-5 Curves showing the relationship between as-built median spectral acceleration capacity, S_{μ} , and base-normalized upper-story strength for various weak-story ratios, A_W , and for the *Onset of Strength Loss* set of drift limits. Strength degradation ratio $C_D = 0.0$.

limit probability of exceedance, POE , may be estimated in each direction using Equation 7-7 and Equation 7-8 for $C_D = 1.0$ and 0.0 , respectively. Linear interpolation may be used for intermediate values of C_D . The drift limit POE of the building shall be the minimum value computed considering each direction independently.

$$POE = 84.0 \left(\frac{S_d}{S_{\mu 1}} - 0.41 \right), \text{ for } C_D = 1.0 \quad (7-7)$$

$$POE = 75.2 \left(\frac{S_d}{S_{\mu 0}} - 0.33 \right), \text{ for } C_D = 0.0 \quad (7-8)$$

where:

S_d = short-period spectral acceleration demand of interest (e.g., S_{MS}),

$S_{\mu 1}$ = median spectral acceleration capacity for strength degradation ratio, $C_D = 1.0$, in accordance with Equation 7-4, and

$S_{\mu 0}$ = median spectral acceleration capacity for strength degradation ratio, $C_D = 0.0$, in accordance with Equation 7-5.

Appendix A

Guide to Weak-Story Tool

A.1 Introduction

The *Guidelines* introduce topics that may be unfamiliar to some engineers. Though the calculations required in Chapters 4 and 5 are not conceptually difficult, the novelty of these concepts might be confusing. Also, there is a significant amount of number-crunching that must be done. This is the direct result of trying to take into account as much of the strength of the existing building as possible to make the retrofit economical. Each wall in the building will participate in resisting instability during an earthquake whether it is considered structural or not; thus each wall must be tabulated, assigned an assembly (and requisite load-drift curve), and be included in the calculations of the strength of each level in each direction and in torsion.

The concept of the Weak-Story Tool is to provide a convenient means of tabulating the walls in a building with clear graphical feedback to clarify the calculations that are being done by the spreadsheet tool. It provides a relatively fast means of going from the building survey through checking if the first-story retrofit is applicable, and if so, to finding the required strength of the retrofitted first story.

A.2 Obtaining the Weak-Story Tool

The Weak-Story Tool is included on a CD accompanying this report. See Section A.4 for installation instructions.

A.3 System Requirements

The Weak-Story Tool was developed using Visual Basic.Net and should work on any Windows machine with Windows XP or later operating system.

A.4 Weak-Story Tool Installation

The installation files will come in the form of a folder called “WeakStoryTool.” (see Figure A-1) Inside the folder will be several items. To install the Tool, simply double-click the file *setup.exe*. The Tool may be removed from the system using the Control Panel as with any similar commercial tool. The Tool launches itself at the end of the installation process. It also places a shortcut in the *Start Menu*.

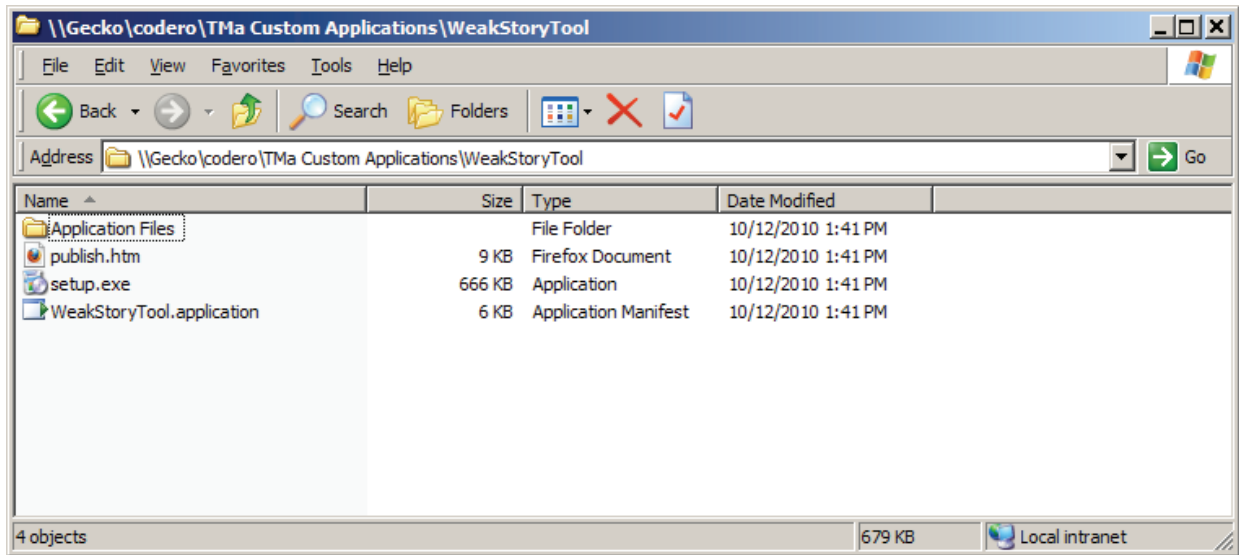

Figure A-1 Screenshot of contents of WeakStoryTool folder containing installation files.

A.5 Basic Controls

When the Tool is launched, a new document will be created. The user must create a unique document for each distinct building to be analyzed. There are four buttons near the top of the screen (see Figure A-2) that determine which control is currently displayed. The following is a list of the controls and their purposes.

1. General: Enter general buildings properties and reference geometry (e.g. gridlines and images) that might be relevant on more than one level.
2. Assemblies: Combine sheathing layers into assemblies that can be assigned to walls.
3. Levels: Define properties for each level including clear story height, wall layout, diaphragm shape, and unit weights.
4. Summary: Review evaluation and performance results indicating the need for and acceptability of retrofit.

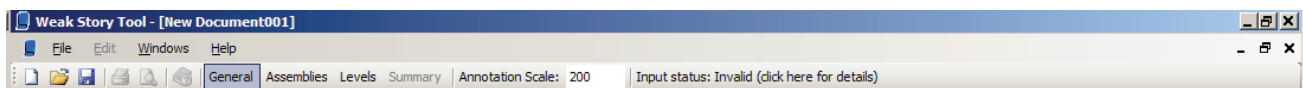



Figure A-2 Screenshot of control buttons.

A.6 General Building Properties and Geometry

The *General* control (Figure A-3) is where the user enters information and geometry that apply to the building as a whole. On the top left of the drafting area, there is a control box where the building properties may be edited. The

user may toggle an expanded view of the available properties by clicking the  (toggle expand) button. The properties are as follows:

1. *Number of Levels*: The number of levels in the building.
2. S_{MS} : The short-period MCE acceleration for this building. Clicking on the  (calculator) button brings up a form that helps the user find site-specific S_{MS} based on zip code and site class as in ASCE/SEI 7-05.
3. *Typical Wall Thickness*: The wall thickness that will appear when the user draws a wall when the *Levels* control is displayed. It has no affect on the calculations.
4. *Description*: Text that describes this building.

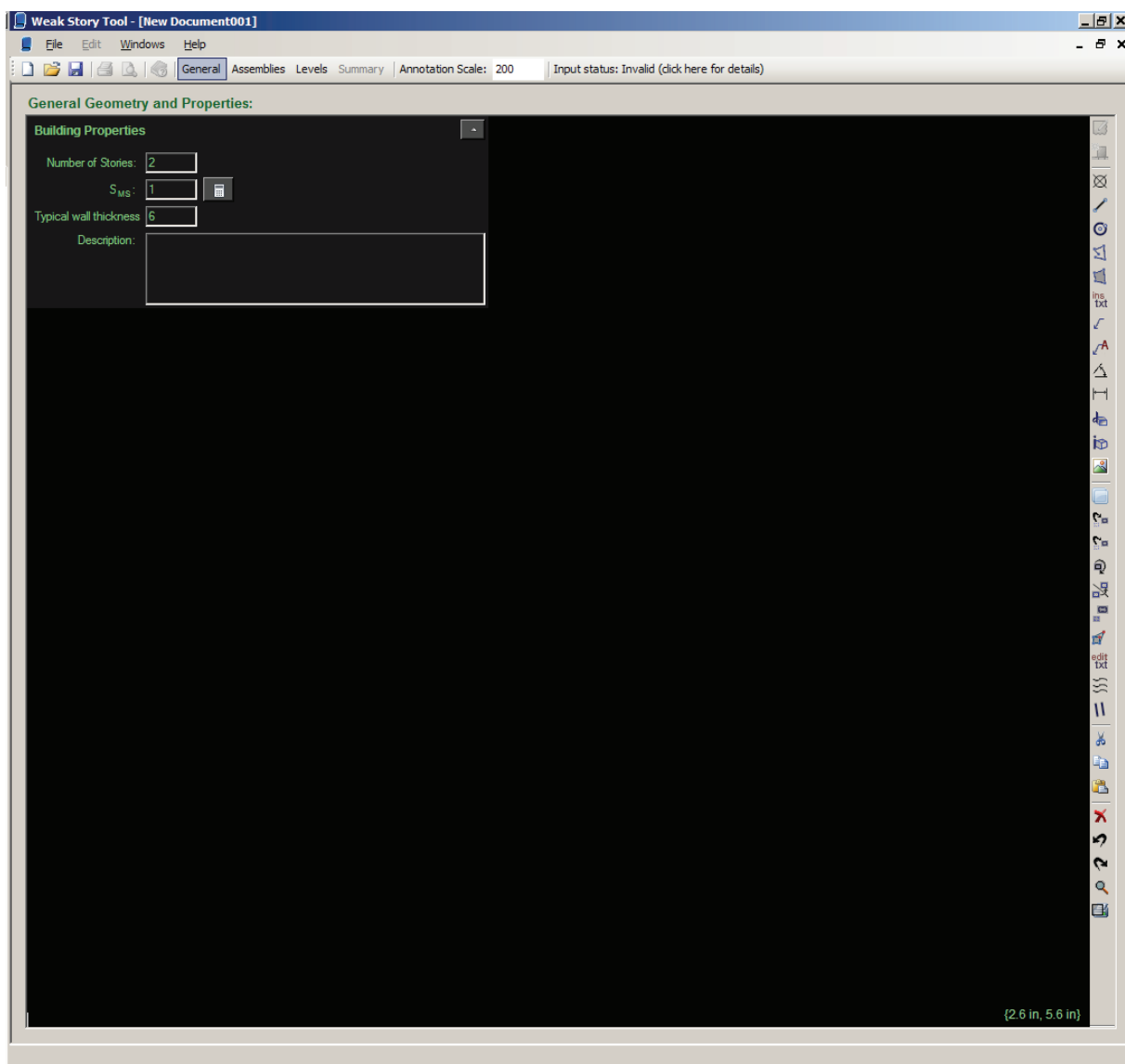



Figure A-3 Screenshot of *General* control.

A.7 CAD Interface

The calculations in the *Guidelines* require a detailed accounting of the locations of the various walls in plan. To accomplish this effectively, the Weak-Story Tool relies on a CAD (computer-aided drafting) interface as the means by which the user will layout the walls.











A.7.1 Analytical Entities























There are two analytical entities that the user can draw in the CAD interface in the Weak-Story Tool: shearwalls and diaphragms. Once the user draws these entities, they are part of the analytical model and will be included in the calculations once their input is valid. One may draw a shear wall or diaphragm when the *Levels* control is displayed (but not in the *General* control) by clicking the appropriate button:

1. : Draw shape of diaphragm; only available when *Levels* control is displayed and active level is an upper (not first) level.
2. : Draw new shear wall; only available when *Levels* control is displayed.

A.7.2 Non-Analytical Entities

The CAD interface in the Weak-Story Tool also has a library of drafting entities that will help the user layout the walls and diaphragms but will not interact with the analysis. The user can create these entities by pressing the appropriate button in the tool strip to the right of the black drafting area. Referring to Figure A-3, the following is a list of commands available from top to bottom:

1. : Draw point.
2. : Draw line. Lines may be drawn to define gridlines for laying out the walls in the *Levels* control (see Figure A-4)
3. : Draw circle.
4. : Draw polyline (i.e., a line with multiple segments).
5. : Draw closed shape.
6. : Set text styles.
7. : Insert text.
8. : Edit text.
9. : Draw leader
10. : Draw leader with text attached.

11. : Draw angular measurement.
12. : Draw linear measurement.
13. : Define block made of a group of entities.
14. : Insert a block.
15. : Insert an image. If a drawing exists, it may be scanned and inserted into the document as a background image for tracing the walls and diaphragms in the *Levels* control. After the image is inserted, it must be scaled and rotated so that distances in the image agree with measured distances from the reconnaissance (survey).
16. : Edit layers. Drawing entities are drawn on layers. These layers may be manipulated in several ways. The line-type, thickness, and color may be changed. They may be hidden or locked against editing.
17. : Move entities.
18. : Copy entities.
19. : Rotate entities
20. : Mirror entities.
21. : Scale entities.
22. : Stretch entities.
23. : Create a linear array of selected entities.
24. : Offset line, circle or polyline entities.
25. : Cut entities to clipboard.
26. : Copy entities to clipboard.
27. : Paste entities from clipboard.
28. : Delete selected entities.
29. : Undo.
30. : Redo.
31. : Zoom.
32. : Set print area.

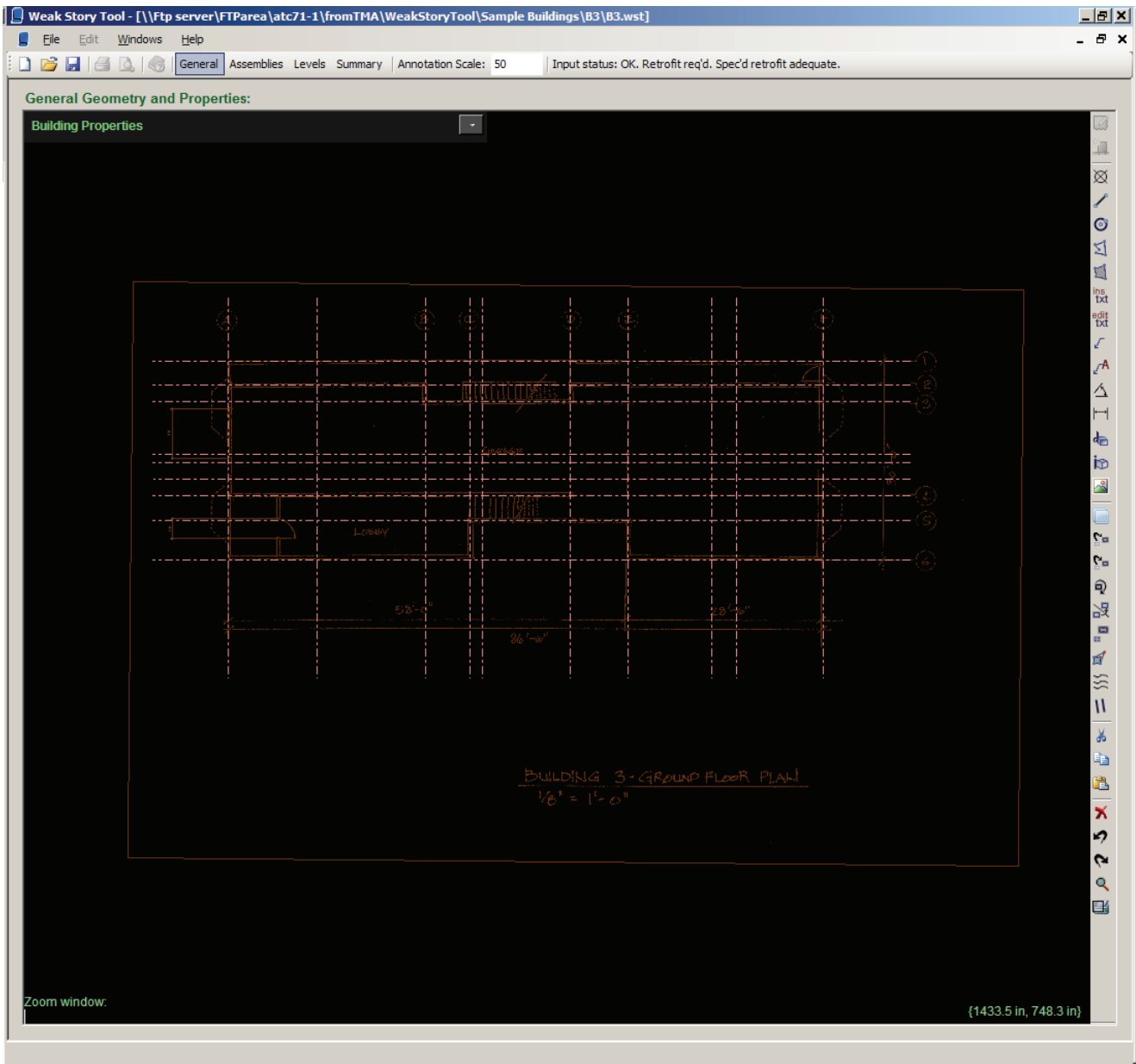

Figure A-4 Reference geometrical input for sample building.

A.7.3 Other CAD Tools

The CAD interface is equipped with “snapping” tools that can be toggled with the *F3* key. The user can also access a particular snapping option by clicking *Shift* and *Right-Click* when the interface is awaiting a point as input. For example, snapping allows the user to draw a line whose endpoint is locked to the endpoint of another line. Other snapping options are available as illustrated in Figure A-5.

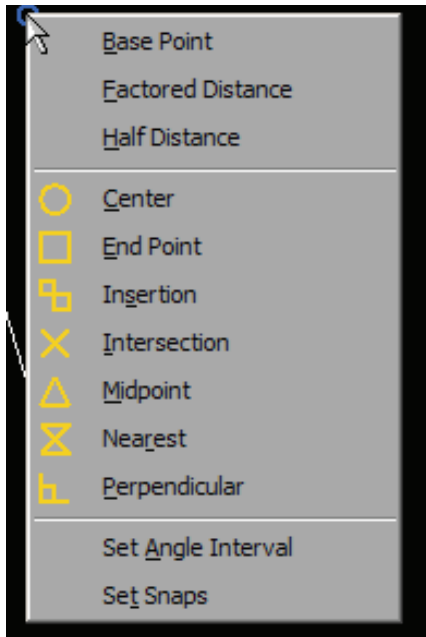

Figure A-5 Screen-shot of object snap menu.

The CAD interface also allows the user to draw lines constrained to a set of specified angles (e.g., 0 deg. or 90 deg.). This may be toggled with the *F8* key, and the angle interval may be set by clicking *Shift* and *Right-Click* when the interface is awaiting a point as input as shown near the bottom of the menu in Figure A-5.

Entities, including shear walls and diaphragms may be copied to and pasted from the clipboard. Type *Control-C* to copy entities to the clipboard and *Control-V* to paste from the clipboard. Entities may be copied from one level and pasted to another.

A.8 Defining Sheathing Assemblies

In the *Assemblies* control, the user may define assemblies that will be assigned to wall (or frame) elements in the *Levels* control. There are fifteen (15) pre-defined sheathing layer types including both finish and wood structural panel types. The list of available layer types appears on the top left (see Figure A-6). The load-drift curves for the default sheathing layer types are read-only.

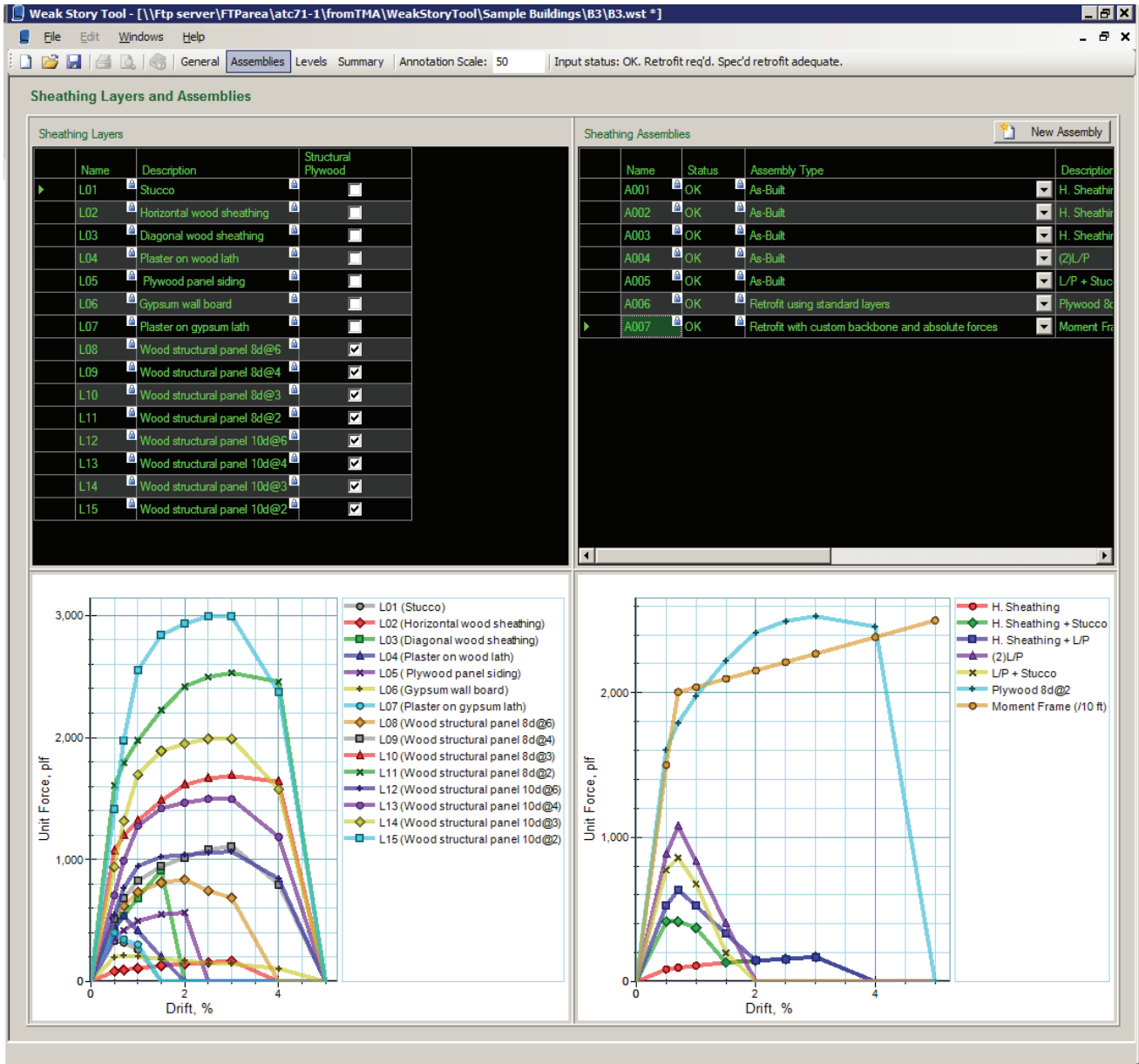

Figure A-6 Screenshot of Assemblies control.

On the top right is the table of sheathing assemblies. The user may create a new assembly by clicking the *New Assembly* button (Figures A-6 and A-7). The user must specify an assembly type. There are four types available:

1. *As-Built*: This assembly is part of the original structure. It comprises layers from the list of sheathing layers.
2. *Retrofit using standard layers*: This assembly is part of the retrofitted structure. It comprises layers from the list of sheathing layers.
3. *Retrofit with custom backbone and forces per unit length*: This assembly is part of the retrofitted structure. The load-drift curve must be entered by

the user, and the loads are expected to be unit loads (i.e. pounds per foot of wall).

4. *Retrofit with custom backbone and absolute forces*: This assembly is part of the retrofitted structure. The load-drift curve must be entered by the user, and the loads are expected to be absolute loads (i.e., kips). This is the option that should be used to model a moment frame.

For assembly types 1 through 3, the load-drift curve for a given wall will depend upon its length. The unit load-drift curve will be multiplied by the length of the wall and factored to account for overturning and perforations to find the load-drift curve for the wall.

For assembly type 4, the load-drift curve for a given element (not wall in this case) will be independent of the length of the element. There will be no factors applied.

Name	Status	Assembly Type	Description	Assembly	Has Structural Plywood	Sheathing Combination	Color Scheme
A001	OK	As-Built	H. Sheathing	L02	<input type="checkbox"/>	100% of all layers	Red
A002	OK	As-Built	H. Sheathing + Stucco	L02+L01	<input type="checkbox"/>	100% of all layers	Green
A003	OK	As-Built	H. Sheathing + L/P	L02+L04	<input type="checkbox"/>	100% of all layers	Blue
A004	OK	As-Built	(2)L/P	(2)L04	<input type="checkbox"/>	100% of all layers	Purple
A005	OK	As-Built	L/P + Stucco	L04+L01	<input type="checkbox"/>	100% of all layers	Yellow
A006	OK	Retrofit using standard layers	Plywood 8d@2	L11	<input checked="" type="checkbox"/>	50% finish, 100% plywood	Cyan
A007	OK	Retrofit with custom backbone and absolute forces	Moment Frame	Custom	<input type="checkbox"/>	Not Applicable	Brown

Figure A-7 Screenshot of table of sheathing assemblies in *Assemblies* control.

If assembly type 1 or 2 is selected, the user must input the assembly specification in the *Assembly* column. This specification is a formatted string in which multiple layer names are joined by plus (+) signs to form the assembly. Multiple layers of the same type may be specified using a number inside parentheses next to the layer name. For example, the string, *L01+L02*, indicates an assembly of one layer of *L01* (Stucco) and one layer of *L02* (Horizontal wood sheathing). The string, *(2)L06+L08*, indicates two layers of *L06* (Gypsum wallboard) and one layer of *L08* (Wood structural panel with 8d nails @ 6" on center).

As an alternate to entering the assembly string directly, if the user clicks the  (ellipsis) button at the right end of the cell, a form will come up that enables a more convenient method of building the assembly string (Figure A-8). In the form, the user may add a layer to the assembly by either double-clicking a layer or by clicking the plus (+) button after selecting a layer.

When wood structural panels exist with finish materials in a wall assembly, the Weak-Story Tool automatically uses the combination rules described in Section 4.5. (The combined capacity is the weaker strength from either 50%

of the structural wood panel layers and 100% of the finish materials, or 100% of the structural wood panel layers and 50% of the finish materials.)

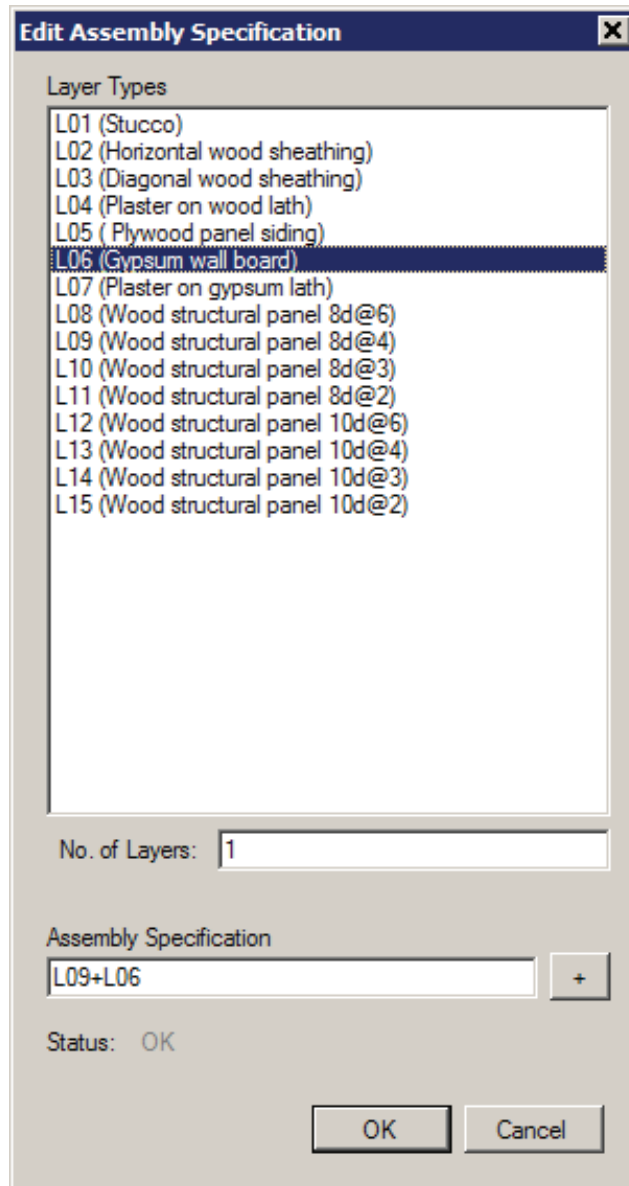



Figure A-8 Screenshot of form for defining assembly specifications for assemblies comprising standard sheathing layers.

If assembly type 3 or 4 is selected, the user must click the  (ellipsis) button at the right end of the cell to define the custom load-drift curve (Figure A-9). In this form, the user simply enters forces (or unit forces as applicable) for certain given drift ratios. After clicking *OK*, the load-drift will be saved to the assembly.

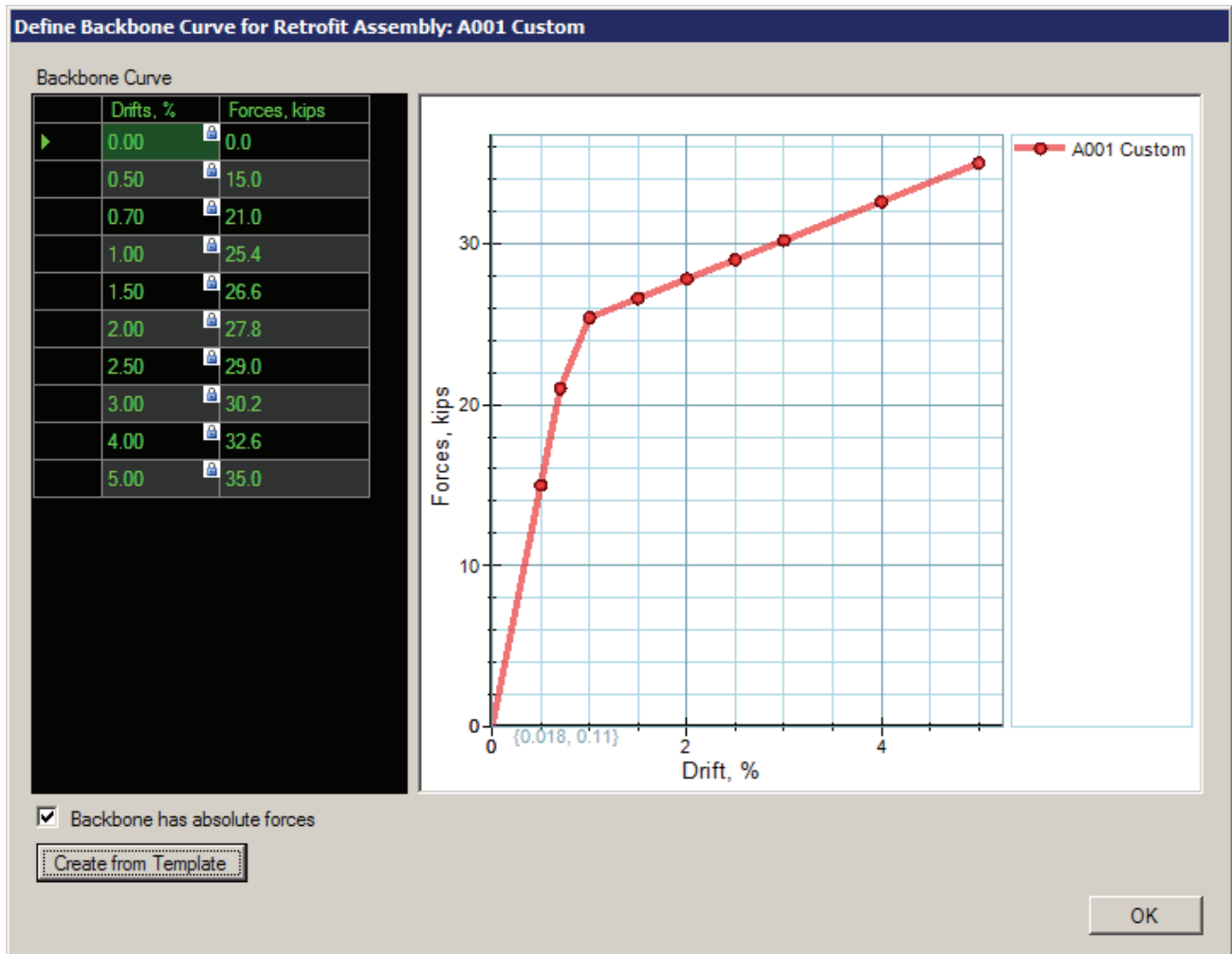



Figure A-9 Screenshot of form for defining custom load-drift curves for retrofit assemblies.

The *Status* column of the assembly table indicates whether an assembly definition is valid. It will have OK if the assembly is valid; otherwise, a message will appear indicating what is wrong. The analysis will not be performed while there are any invalid assemblies.

A.9 Assigning Level Properties and Laying Out Walls

In the *Levels* control, the user may draw walls, define diaphragms, and assign properties to each level including unit weight and story height. The combo box at the top of the control indicates which level is currently active; the First story is active in the screenshot in Figure A-10. The user may specify the number of levels in the *General* control. The user may activate another level by selecting it from the list or by clicking the  (cycle) button.

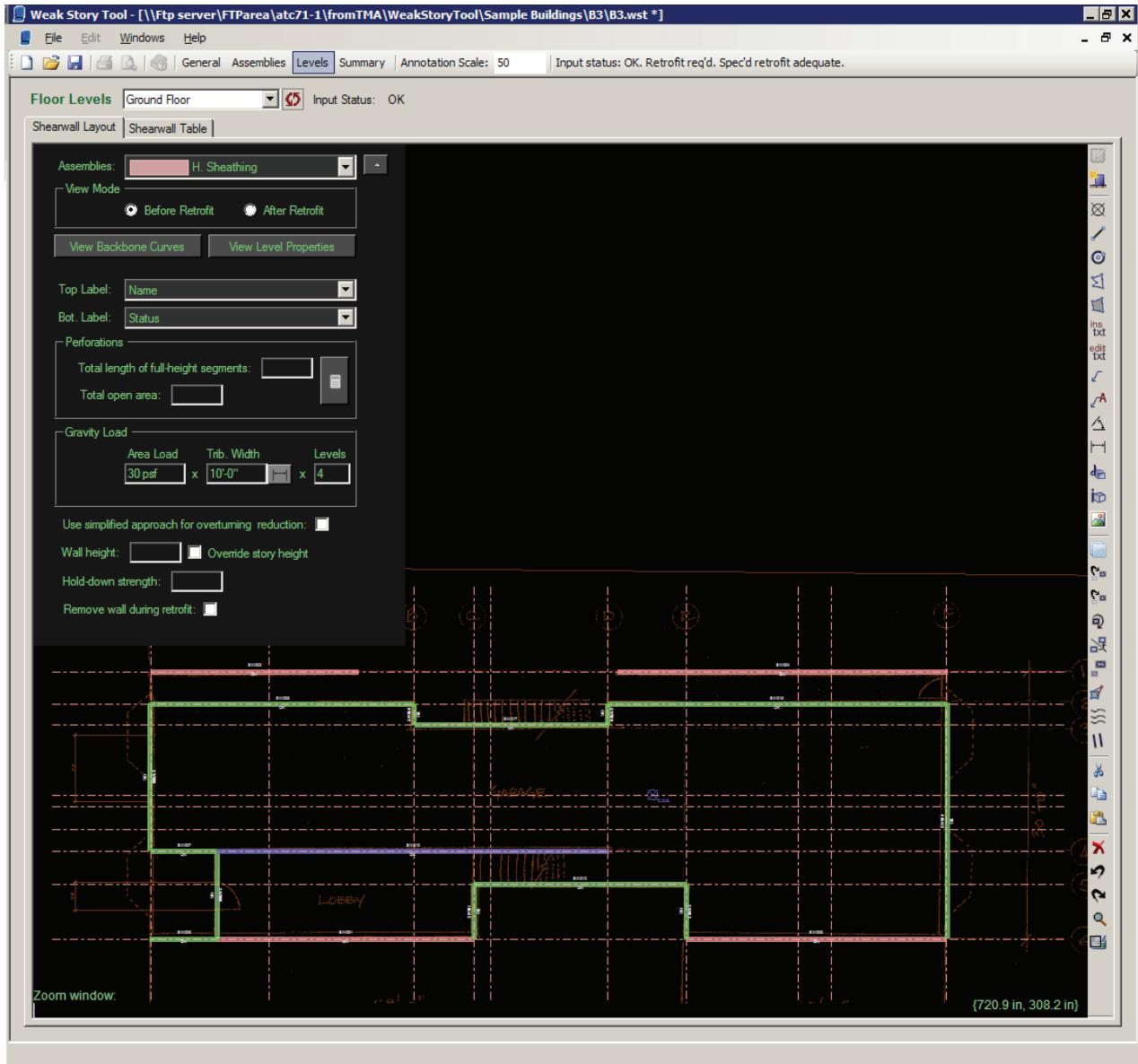

Figure A-10 Screenshot of the *Shearwall Layout* tab in the *Levels* control for an example building. The first story is active.

A.9.1 The *Shearwall Layout* Tab

When the *Shearwall Layout* tab is selected, a set of options and controls appear in the control box on the top left of the drafting area. The user may toggle an expanded view of the available options by clicking the ∇/\blacktriangle (toggle expand) button. The following is the list of options and controls:

1. *Assemblies*: Shows the assembly that is currently active. When new shear walls are drawn, they will automatically be assigned the active assembly. If the user selects a different assembly, the selected walls will be assigned the new assembly. Retrofit assemblies will only appear in the

list if the active level is the first story and the *View Mode* is set to *After Retrofit*.



2. *View Mode*: Sets the view mode for the drafting area. When *View Mode* is set to *Before Retrofit*, all walls assigned retrofit assemblies will be hidden; all other walls will be visible. When *View Mode* is set to *After Retrofit*, all walls marked *Remove wall during retrofit* will be hidden; all other walls will be visible.
3. *View Backbone Curve* (button): Brings up a control showing backbone curves for the active level. If no walls are selected, backbone curves for all walls will show. If some walls are selected, then the load-drift curves of the selected walls will be highlighted. If the *Add Curves* checkbox is checked, the forces of the load-drift curves of the selected walls (or all walls if none are selected) will be added and displayed as a separate curve. This control is only relevant to the first story.
4. *View Level Properties* (button): Brings up a control showing the properties of the level: unit weight, story height, and color scheme. Other read-only data for level will also be displayed for the user's interest.
5. *Top Label*: specifies the type of label that will appear above each wall.
6. *Bot. Label*: specifies the type of label that will appear below each wall.
7. *Perforations/Total length of full-height segments*: Specifies the total length of full-height segments for each of the selected walls. Clicking on the  (calculator) button brings up a form (Figure A-11) that helps the user calculate the full-height segment length and open area. In this form the user adds openings of specified width and length, and after OK is clicked, the program computes the full-height segment length and open area values and assigns them to the selected walls.
8. *Perforations/Total open area*: Specifies the total open area for each of the selected walls.
9. *Gravity Load*: Allows user to specify the amount of gravity-load tributary to the selected walls. The load will be used only if the simplified overturning adjustment approach is not selected. If the simplified approach is used, the specified number of levels determines the overturning adjustment factor, Q_{ot} .

Figure A-11 Screenshot of the perforation calculator form in the *Levels/Shearwall Layout* control.

10. *Use simplified approach for overturning adjustment*: If checked, the gravity load on a given wall is ignored and the simplified approach is used, given the specified number of levels. The framing direction is considered unknown. This option is only relevant to walls with non-retrofit assemblies.
11. *Wall height*: Specifies the clear height of the selected walls if the *Override story height option* is checked. By default, walls will acquire their height from the level. The *Wall height* property is used to determine the drift ratio adjustment for walls in the first story with a height that is different than the maximum wall height.
12. *Hold-down strength*: Specifies the hold-down strength at the end of each wall. This property is relevant only if the simplified approach for overturning adjustment is not selected. Any new retrofit walls must have sufficient hold-down strength to yield an overturning adjustment factor, Q_{ob} , of zero.
13. *Remove wall during retrofit*: Determines if wall will remain after retrofit. In some cases, the user may wish to add wood structural sheathing to an existing wall. This is done by first copying the assembly of the existing

wall, assigning it the retrofit type, and adding wood structural sheathing. The existing wall must be copied (but not moved). One of the duplicate walls must be marked *Remove wall during retrofit* and the other assigned the new retrofit assembly. This control is only relevant to the first story.

Once a level is made active, any entities, including drafting entities like lines or images and analytical entities like shear walls will be added to that level. Those entities will only appear when that level is active. This is distinct from entities added on the *General* control.

The user may draw a new wall by clicking the  (draw shearwall) button at the top of the CAD tool strip on the right. If the active level is not the first story, the user may draw the diaphragm shape by clicking the  (draw diaphragm) button.

A.9.2 Shearwall Table

The shearwall table lists all the walls on the active level with their properties. Many shear-wall properties may be edited in the table or graphically in the *Shearwall Layout* tab.

A.10 Evaluation and Retrofit Summary

As the user adds assemblies and walls to the model, the Weak-Story Tool is constantly checking whether the input is valid. Once the input has been validated, the *Summary* control button near the top of the screen will be enabled. If a change is made that causes the input to be invalid, the *Summary* control button will be disabled until the input is again made valid.

The combo box near the top right of the control sets the drift limit probability of exceedance considered in the evaluation. The following is a list of the three tabs in the *Summary* control and their relevance:

1. *Evaluation Data*: Shows the textual summary of the analysis.
2. *Backbone Curves*: Plots of the load-drift curves of the various levels.
3. *Performance Data*: Written and graphical summary of predicted probabilistic seismic performance.

A.10.1 Evaluation Data Tab

In the *Evaluation Data* tab, the *Evaluation Log* is displayed (Figure A-12). It shows all the values calculated by the Weak-Story Tool that are relevant to the evaluation. The log consists of three sections: *Torsion Properties*, *X-Direction*, and *Y-Direction*.

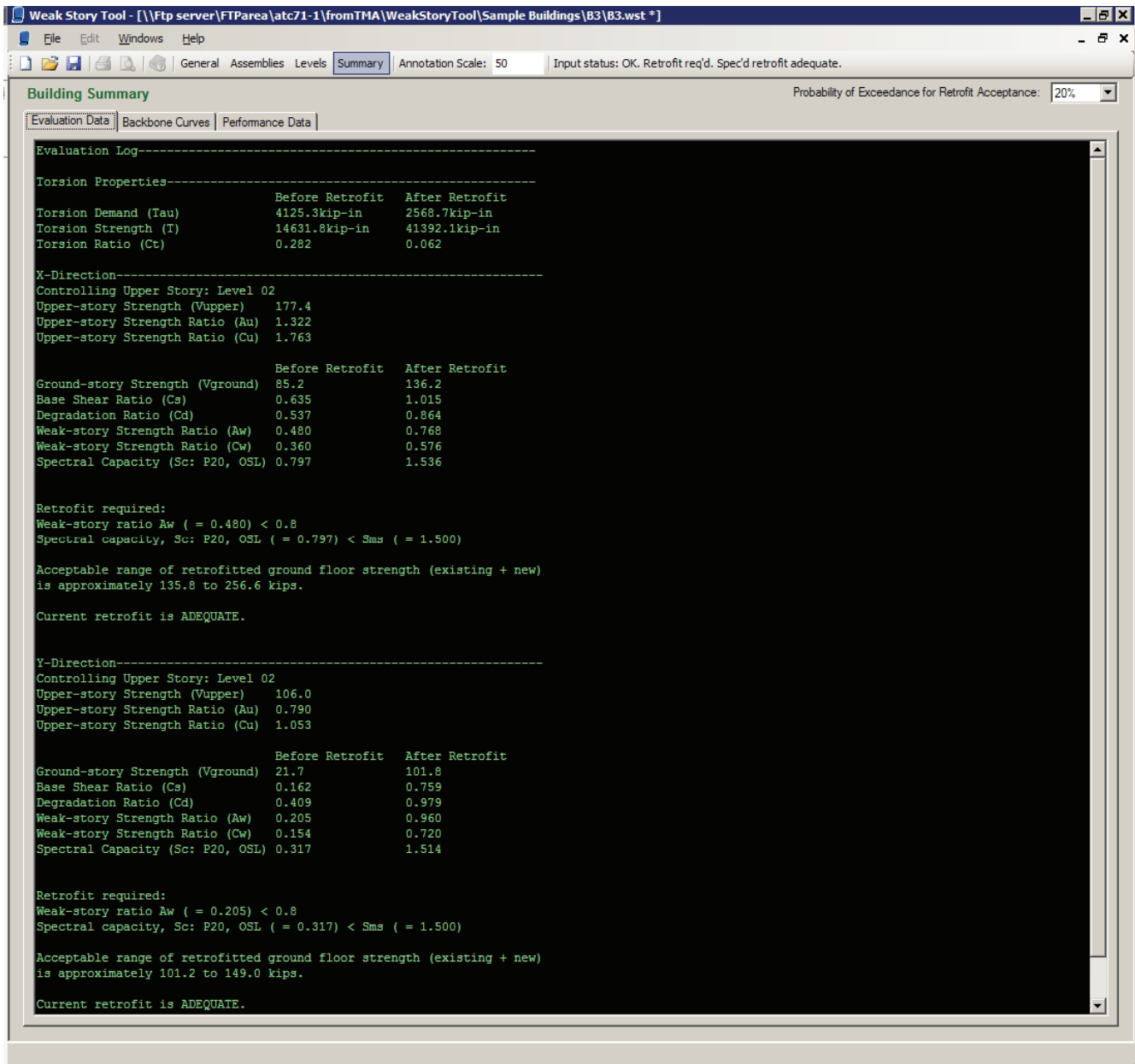

Figure A-12 Screenshot of the *Evaluation Data* tab in the *Summary* control for an example building.

Under *Torsion Properties*, the user can find the data required to compute the Torsion Coefficient, C_T , defined in Chapter 4 of the Guidelines.

For each orthogonal direction, x and y , the following information is presented:

1. *Upper-story data*: controlling story (i.e., the upper story with the smallest ratio of shear strength to weight above), upper-story shear strength, V_U , base-normalized upper-story, A_U , and minimum of the story-normalized strength, C_U , of the controlling upper story.

2. *Table of relevant data before and after retrofit:* First-story strength, V_1 , Base shear ratio, C_1 , strength degradation ratio, C_D , weak-story ratio, A_w , and spectral acceleration capacity evaluated at the specified drift limit probability of exceedance for the *OSL* (onset of strength loss) drift criteria.
3. *Retrofit data:* If the structure before retrofit meets certain standards defined in the *Guidelines*, the Weak Story Tool will report that no retrofit is required. Otherwise, the program will note which standards were not met, give the range of the acceptable total (new plus existing) first-story strength after retrofit, and report whether the current retrofit is adequate. The minimum retrofitted strength is an estimate reported for the user's convenience; the actual goal is to meet one of the following conditions:
 - a. Get the spectral acceleration capacity after retrofit below the default (embedded) site-specific spectral acceleration demand, S_{MS} , given the specified drift limit probability of exceedance, if this is possible without exceeding the maximum allowed retrofit strength, or
 - b. Strengthen the retrofitted first-story to within $\pm 10\%$ of the maximum allowed to increase the spectral capacity as high as possible within the constraint of the first-story only retrofit.

A.10.2 Backbone Curves Tab

In the *Backbone Curves* tab, the user has the ability to view backbone curves of the various levels. For the first story, the user may compare backbone curves before (Figure A-13) and after (Figure A-14) the retrofit. There are plotting options to view the forces (y-axis) in terms of force story-normalized or base-normalized weak-story ratio.

A.10.3 Performance Data Tab

In the *Performance Data* tab (Figure A-15), the user can review the effect of the retrofit in probabilistic terms. There are two drift criteria considered as defined in the *Guidelines*: *OSL* (onset of strength loss), and *OD* (onset of damage). On the top left, there is a text console summarizing the retrofit effect. It is broken into four sections:

1. *Change in Drift Limit Probabilities of Exceedance due to Retrofit:*
Summarizes the change in drift limit probability of exceedance due to the retrofit for each set of drift criteria.

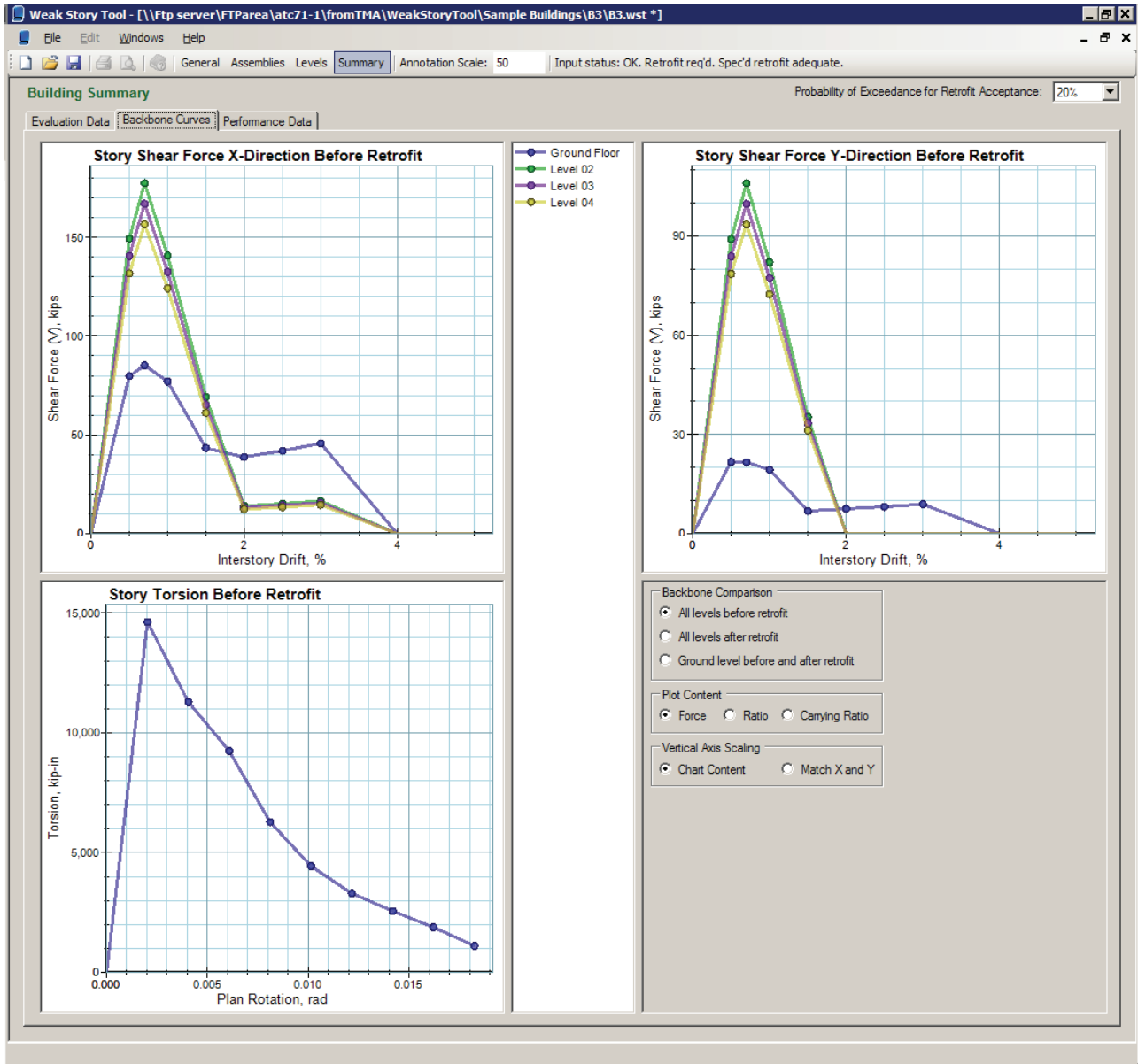

Figure A-13 Screenshot of the *Backbone Curves* tab in the *Summary* control for an example building showing first-story load-drift curve before retrofit.

2. *Envelope of X- and Y-Direction*: Table comparing drift limit probabilities of exceedance for each set of drift criteria before and after retrofit.
3. *X-Direction*: Table comparing values of lognormal standard deviation (β), mean spectral acceleration capacity, and drift limit probability of exceedance for each set of drift criteria before and after retrofit in the x -direction of the building.
4. *Y-Direction*: Same as to *X-Direction* table but for the y -direction of the building.

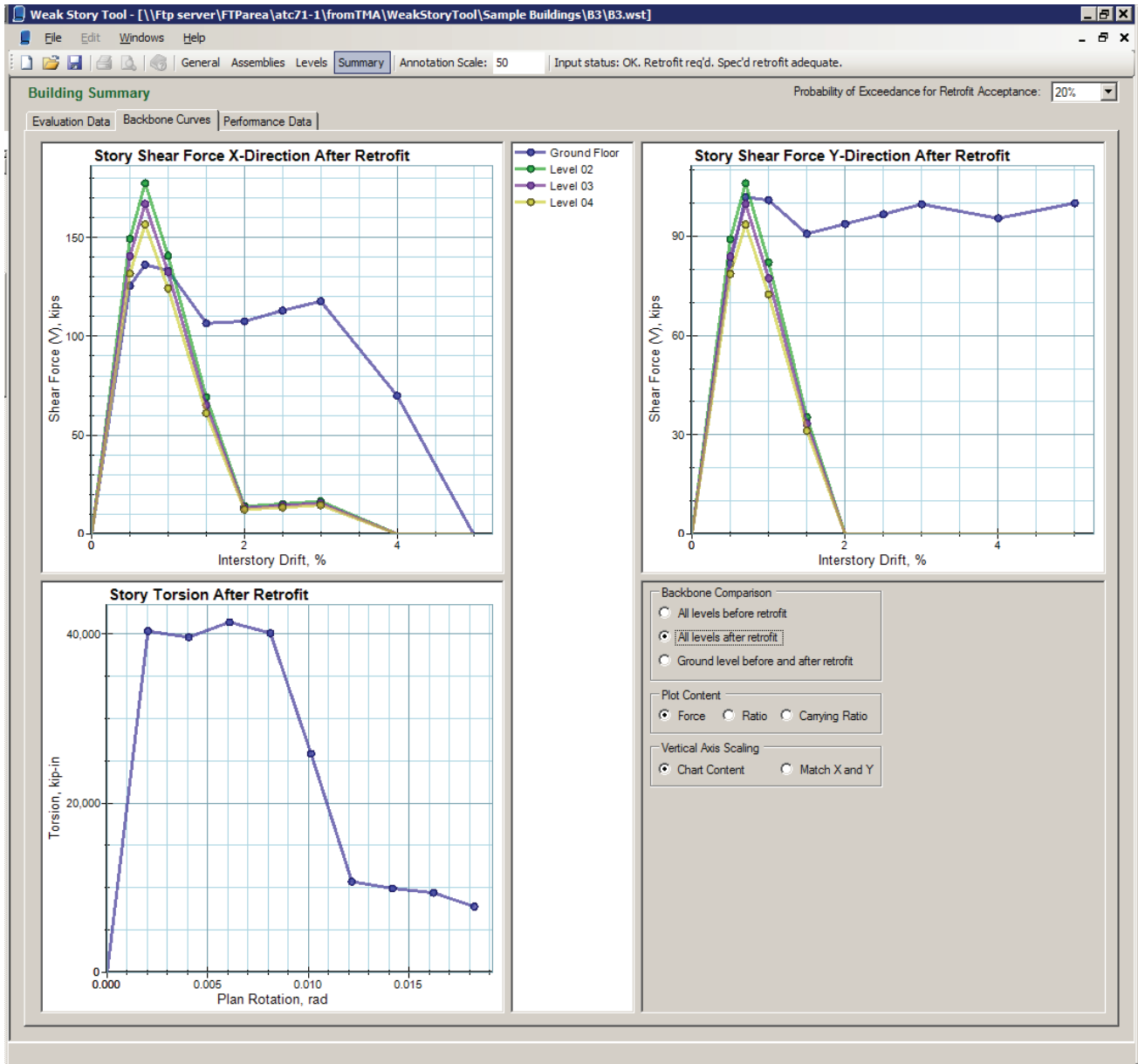

Figure A-14 Screenshot of the *Backbone Curves* tab in the *Summary* control for an example building showing first-story load-drift curve after retrofit.

On the bottom of the *Performance Data* tab are two charts. The left chart is for the *x*-direction of the building; the right is for the *y*-direction. Each chart shows two fragility curves relating drift limit probability of exceedance of the specified drift criteria (vertical axis) with spectral acceleration (horizontal axis). One curve corresponds to the building before retrofit, the other after retrofit. The user may change the drift criteria by selecting the desired option in the top right area of the *Performance Data* tab.

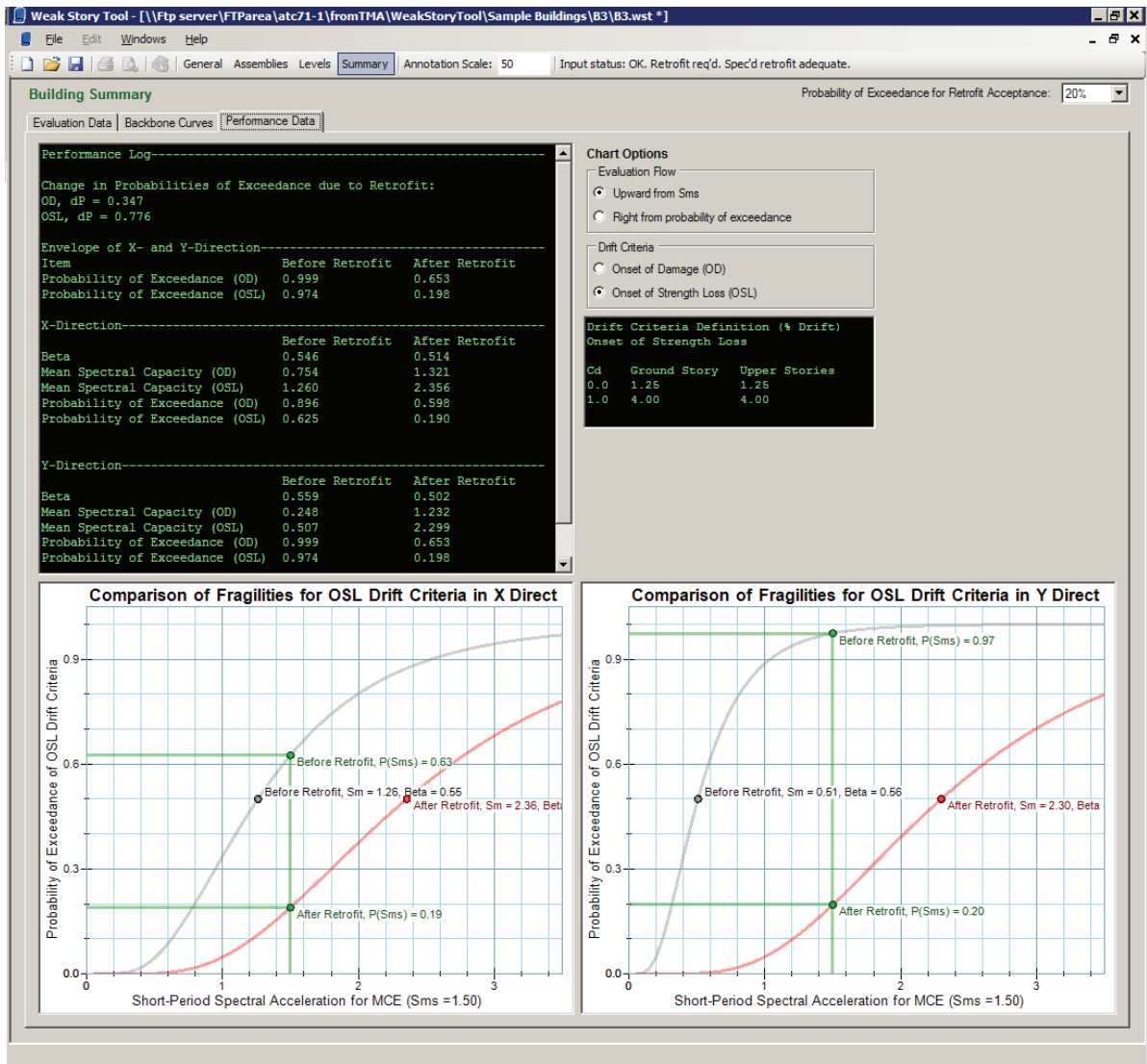

Figure A-15 Screenshot of the *Performance Data* tab in the *Summary* control for an example building.

The user may toggle the flow of the performance evaluation between *Upward from S_{MS}* (Figure A-16) and *Right from drift limit probability of exceedance* (Figure A-17). In the first flow, the evaluation starts along the horizontal axis at the S_{MS} spectral acceleration demand. A vertical line going up from there will intersect each fragility curve at two different drift limit probabilities of exceedance. The distance between these two intersections represents the change in drift limit probability of exceedance due to the retrofit. In the second flow (Figure A-17), the evaluation starts along the vertical axis at the specified drift limit probability of exceedance. A horizontal line going to the right from there will intersect each fragility curve at two different spectral accelerations. The distance between these two intersections represents the change in spectral acceleration capacity due to the retrofit.

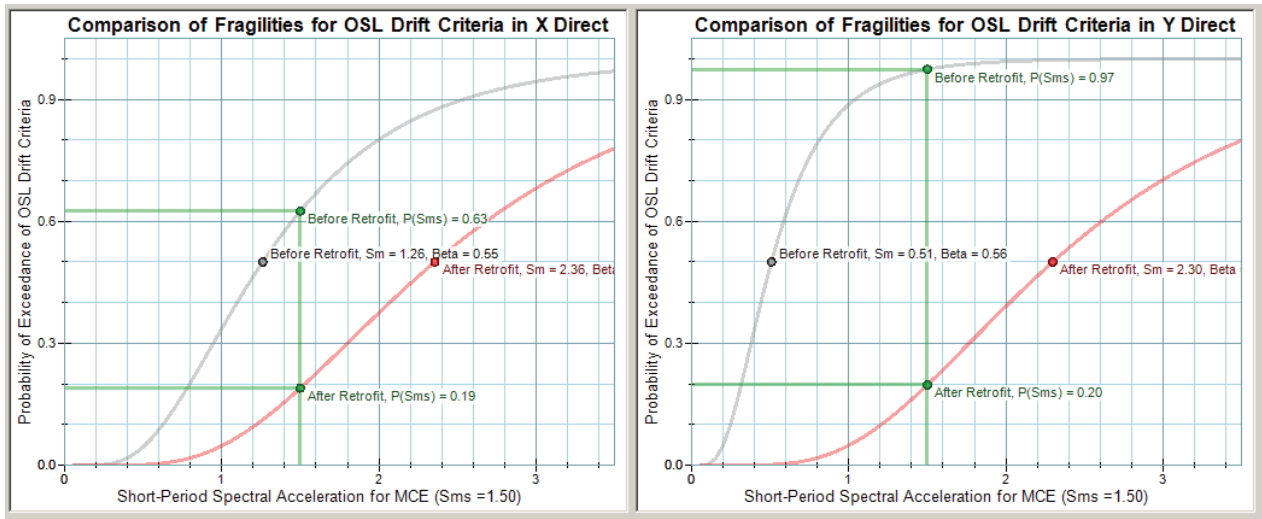

Figure A-16 Illustration of evaluation flow *Upward* from S_{MS} .

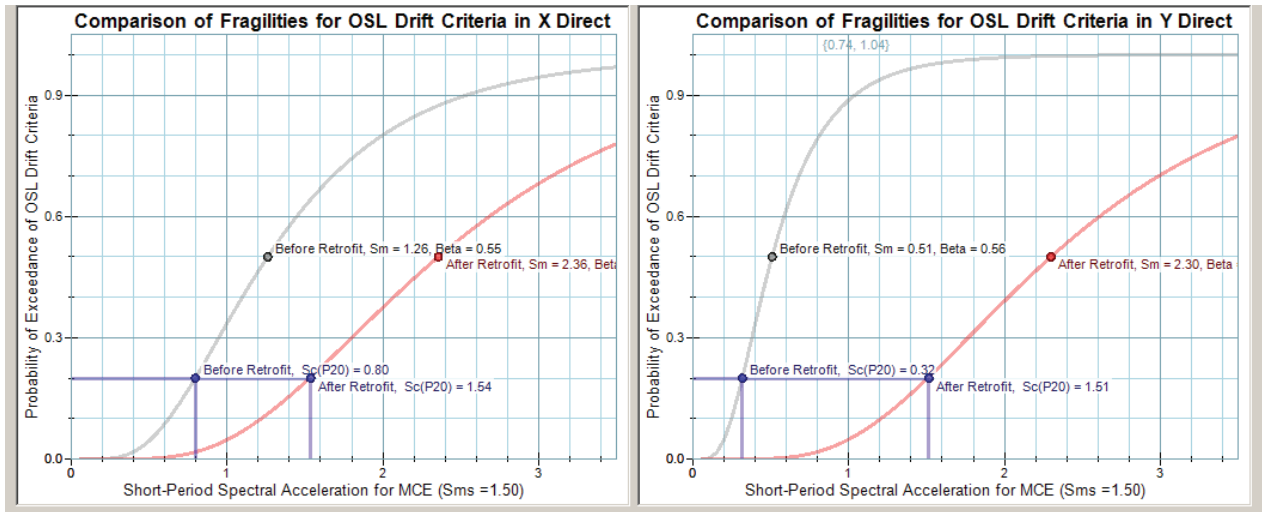

Figure A-17 Illustration of evaluation flow *Right* from drift limit probability of exceedance.

Appendix B

Model Provisions for Mitigation Programs

This appendix extends ideas introduced in *Guidelines* Section 1.4 regarding targeted mitigation programs—mandatory programs or incentive-based voluntary programs. In these programs, the work must meet a defined standard (unlike purely voluntary work), but that standard may be different from the one implied by building codes.

Despite differences from the building code, targeted mitigation programs still typically rely on provisions written in “code language” to ensure consistency and enforceability. This appendix presents the *Guidelines* evaluation and retrofit methodology in code language suitable for adoption through a local ordinance.

B.1 Targeted Mitigation Programs

As discussed in Section 1.4, seismic mitigation can generally be categorized as voluntary, mandatory, or triggered. Purely voluntary mitigation, by definition, need not satisfy any legislative, code, or regulatory requirements in terms of how, or how much, it improves earthquake performance. Triggered mitigation occurs only when some other intended project—a repair, a major alteration, or a change of occupancy, for example—requires it as a condition of code compliance. For an individual building, voluntary or triggered mitigation can be extremely effective and valuable. From the perspective of a jurisdiction thinking about a citywide building stock, however, voluntary and triggered work is comparatively piecemeal and unpredictable. It is very hard to know in advance how much earthquake risk will be reduced citywide by purely voluntary or triggered mitigation.

By comparison, targeted mitigation—through a legislated program involving mandates and/or incentives—is generally more predictable and effective at a city scale. Targeted mitigation programs have other advantages as well:

- They can be developed and coordinated as part of a larger earthquake risk reduction plan, for example, one that considers the vulnerability of different economic sectors, demographic groups, building uses, and geotechnical hazards.

- They can be phased as needed to match the resources of the affected owners and tenants, as well as the regulators charged with their implementation.
- They can be customized technically, with performance objectives different from those of the building code—specifically, with objectives linked to a city’s loss or recovery goals.

The *Guidelines*, while suitable for voluntary use and adaptable to building code contexts, were developed especially to facilitate targeted programs.

The following subsections discuss how the *Guidelines* might be used within a typical mandatory mitigation program administered by a local government. Not discussed are several preliminary or developmental phases, including raising public awareness, building political consensus, securing bond funding, and vetting legal issues. While important, even critical, these are outside the scope of the *Guidelines*.

B.1.1 Planning and Program Development

This initial phase should include an inventory effort, some initial loss or performance estimation based on that inventory, and some tentative goal setting. The overall purpose is to understand how the contemplated mitigation program for wood-frame multi-unit residential buildings would relate to broader jurisdiction goals regarding, for example, emergency management, housing recovery, or public safety.

The initial inventory and loss estimation are important because the *Guidelines* recognize that certain buildings (those with especially weak upper stories) have only limited room for improvement with first-story-only retrofits. Understanding how many of these buildings a city has relative to its overall stock, and how little or how much they might be improved, will inform decisions about performance objectives. Case studies using *Guidelines* Chapters 3 through 7 can advance this understanding.

The setting of program and project objectives, discussed further in Section B.2, should ask what performance would be needed from each building in the target class (multi-unit wood-frame) to meet the performance goal for the class as a whole. It should also consider the broader context of the program by asking what performance would be needed from the class to meet the goals for a broader sector (e.g., housing, small businesses) or for the jurisdiction as a whole.

B.1.2 Screening

Typical mandatory retrofit programs define a target class of buildings. The current Oakland, California program, for example, requires compliance from any building built before 1990 with two or more stories, five or more units, and non-residential first-floor occupancy (Oakland Municipal Code, 2010). Since it is often impossible to know in advance precisely which owners will be mandated to act, a screening phase can be beneficial. A basic screening phase merely confirms that compliance notices were sent to the targeted buildings and owners. If an owner is supposed to be exempt from the program, the screening process should give her/him a quick and inexpensive means to show it.

A more sophisticated screening process can also be used to triage the mandated buildings, culling those that would obviously pass or obviously fail a rigorous evaluation. In concept, any building that meets the screening objective would be deemed to comply with the requirements of the program and would be exempted from further work, except as needed to confirm any assumptions made by the screening. Buildings that failed the screening would move into the next phases of the program.

Ideally, a predictive screening tool would be based on attributes that are easy to confirm, perhaps even without the need for professional consultants. Unfortunately, such a tool does not yet exist, and the simplified evaluation method in *Guidelines* Chapter 3 suggests that any reliable evaluation, even just for triage purposes, must consider actual building conditions in engineering terms (as opposed to simple measures of floor area or wall length). Nevertheless, *Guidelines* Chapter 3, which is intended to approximate a full evaluation with less effort and less cost, might be useful in a screening phase.

B.1.3 Evaluation

The evaluation and retrofit phases are the guts of a mitigation program. A separate evaluation phase, while not strictly necessary, offers several benefits. It simplifies the initial tasks for the mandated owner, allowing her/him to engage an engineer for a small and relatively certain scope. It provides an intermediate review step for the code official. It allows a jurisdiction to start the mitigation process without having all the logistics of the retrofit phase in place. Most important, it allows room to revise the retrofit scope or criteria based on analysis of the evaluation findings.

Instead of requiring a pass/fail evaluation to a pre-set drift limit probability of exceedance (*POE*), a phased mitigation program using the *Guidelines*

could require each owner to report the building's actual drift limit *POE* using concepts in Section 5.4.2. From the reported results, a jurisdiction could better estimate the benefits and costs of mandated retrofits, or could adjust the retrofit criteria to suit broad program objectives.

While the *Guidelines* provide clear evaluation criteria, they only apply to eligible buildings (see Section 2.6). A mitigation program should provide suitable alternatives that would apply to any mandated building. Even where the *Guidelines* are adopted, ASCE/SEI 31, *Seismic Evaluation of Existing Buildings*, ASCE/SEI 41, *Seismic Rehabilitation of Existing Buildings*, and *International Existing Building Code* (IEBC) Chapter A4 remain available as more general criteria, assuming they support the program's objective. However, as discussed in *Guidelines* Sections 6.2.3 and 6.4.2, Chapter A4 can lead to over-strengthening of the first story without due regard for potential damage in upper stories. Therefore, while Chapter A4 might be suitable for some *Guidelines*-ineligible buildings, it is not recommended for buildings with very weak upper stories.

As in the screening phase, any building that meets the evaluation objective would be deemed to comply with the requirements of the program and would be exempted from further work, except as needed to confirm any assumptions made by the evaluation. Buildings that failed the evaluation would move into the next phases of the program.

Alternatively, owners might be given the option of moving straight to retrofit, bypassing any requirements to file a detailed evaluation of existing conditions. In the recent Berkeley, California program, this approach resulted in a significant number of retrofits even when no retrofit mandate was in place (Rabinovici, 2012).

B.1.4 Retrofit Prioritization

This optional phase offers an opportunity to adjust the program based on the findings of the evaluation phase. Conceivably, the retrofit mandate could be scheduled, funded, or otherwise fine-tuned based on the newly available information. Even the retrofit objective could be changed if evaluations reveal a much greater or smaller risk than anticipated.

A separate prioritization phase represents a more deliberate (and probably longer duration) program in which the criteria and logistics of the retrofit phase might not be well-defined at the outset. If such a prioritization phase is not used, the evaluation and retrofit phases can still be separate, or they can be combined to any degree as might be convenient to the jurisdiction and the mandated owners. For example, some buildings might move straight to a

retrofit mandate based on screening alone, or owners might be excused from the evaluation if they commit to perform a retrofit.

B.1.5 Retrofit

The final phase of the program involves the retrofit work itself, using *Guidelines* Chapter 6 (or appropriate alternative provisions for *Guidelines*-ineligible buildings). If not done during the prioritization phase, the retrofit phase also involves confirming the retrofit objective and the maximum acceptable drift limit *POE* for optimized retrofits.

B.2 Program Performance Objectives

As described in Sections 1.4.1 and 2.3.2, the *Guidelines* require the selection of three parameters to define a performance objective—hazard level, performance level, and desired drift limit probability of exceedance (*POE*). In addition, the *Guidelines* support waiving the defined objective in some cases, in the interest of balancing the benefits and costs of a first-story-only retrofit.

As applied in the *Guidelines*, however, this combination of parameters, waivers, and limits constitutes primarily the objective for an individual building. Whether established by a jurisdiction as part of a targeted program, or selected by an owner for a single voluntary project, the objective does not directly address the likely performance of the targeted class or of the building stock as a whole. Similarly, a recovery objective for a city does not always translate directly to a performance objective for individual retrofits. To relate program objectives to project objectives, one needs to consider how the targeted class of buildings relates to the housing (or building) stock as a whole and how the distribution of the targeted class relates to the sources of seismic risk (primarily by fault distance).

To be sure, as noted in *Guidelines* Section 1.4.1, a jurisdiction that knows it has a significant number of obviously deficient buildings can probably achieve a measurable improvement with almost any program objective, even if that objective is not derived from a broader mitigation policy. For example, consider a program that mandates first-story retrofit of all three-story or taller wood-frame residential buildings to the following objective:

No more than a 20 percent probability of exceeding the onset of strength-loss drift levels in a Maximum Considered Earthquake (MCE), with the exception that any optimized first-story-only retrofit will be deemed to comply as long as it does not have a drift limit *POE* greater than 50 percent.

If a thousand buildings are retrofitted to that objective, there is no question that some measure of earthquake risk will have been reduced both for individual buildings and for the jurisdiction as a whole. However, the following questions, among others, remain:

- Of the thousand buildings, how many ended up at the desired drift limit *POE* of 20 percent or less, and how many qualified for the exception and ended with a *POE* between 20 percent and 50 percent? How many residential units ended up in each group?
- In most areas, the MCE is an aggregation of possible events from a number of different fault sources. Of the thousand retrofitted buildings and their residential units, what percentage is expected to see drifts exceeding the stated limits in an MCE event from source A west of the city? What is the percentage if the event is from source B east of the city?
- Given a scenario event, if it can be projected that 70 percent of the thousand retrofitted buildings will experience drifts under the stated limits, how would that affect the performance of the citywide housing stock, which includes 50,000 buildings not covered by the program?

If the jurisdiction has loss or recovery goals that look beyond one class of structures, it should perhaps be asking questions such as these when designing its mitigation programs. For example, a jurisdiction goal might be to preserve low-income housing, or to limit the need for emergency shelters. Meeting these goals will depend in part on the performance of wood-frame multi-unit buildings. But it will also depend on other structure types, and the programs needed to meet such goals will likely vary from city to city.

A jurisdiction with a high proportion of wood-frame multi-unit housing will need most of those individual buildings to perform well in order to meet any overall goal for its housing stock. A jurisdiction with only a small percentage of its units in this building type can perhaps set a less aggressive objective and still meet its overall goal, assuming other housing types perform well.

Also, a large target class of similar buildings spread across a city will perform better as a group than its worst-performing members, simply because ground shaking from any single earthquake varies from place to place. Therefore, it might sometimes be possible to set only a moderately aggressive performance objective for each building and still achieve acceptable performance from the class as a whole.

To summarize, a performance objective, as applied in the *Guidelines*, is always for an individual building. A mitigation program, by contrast, seeks

to achieve certain benefits for the jurisdiction as a whole. Therefore, when selecting a performance objective to be mandated by a program, the right objective is the one that achieves the overall quantitative program goals when applied to each individual building.

B.3 Model Provisions and Commentary

Most mitigation programs, even if they are enacted by legislation and not through the building code, rely on regulations written in code-like language. These will differ in style and content from the text of the *Guidelines*. This section provides regulatory language intended to help a jurisdiction implement the *Guidelines*' ideas and recommendations. Where regulatory language is adopted, the *Guidelines* document remains a useful reference and commentary.

As discussed in *Guidelines* Section 1.4.1, implementation of the *Guidelines* requires selection of several parameters related to performance objectives:

- *Hazard level*. The model language below leaves this as a variable to be selected.
- *Performance level*. The model language below assumes the “onset of strength loss” level, which is also assumed by the equations in *Guidelines* Chapters 5 and 6. If the “onset of damage” level is preferred, certain provisions (including text in Section 1 below and equations in Section 6 and 7 below) will need to be adjusted in accordance with *Guidelines* Chapter 7.
- *Desired drift limit probability of exceedance (POE)*. The model language below leaves this as a variable to be selected.
- *Maximum acceptable drift limit POE for optimized retrofits*. The model language below leaves this as a variable to be selected.

Note that the two drift limit *POE* values may be kept the same through all phases of the mitigation program or may be strategically varied by phase. For example, the drift limit *POE* for evaluation could be set high (lenient) so as to catch only the worst buildings, while the drift limit *POE* for retrofit would be set lower (more strict) to ensure a significant improvement. Or, if the jurisdiction is prepared to allow optimized first-story retrofits to a maximum drift limit *POE* of, say 40 percent, it could set the drift limit *POE* for evaluation to match, but set the desired drift limit *POE* for retrofit at a lower, stricter level. (Similarly, though not reflected in the model language below, the drift limit *POE* for screening or triage using *Guidelines* Chapter 3 could be set at a high value to screen out all but the worst buildings or to compensate for conservatism inherent in the simplified evaluation rules.)

Following, in code language and format, are proposed model provisions for implementing the basic provisions of the *Guidelines*. In some instances, the notation and terminology differ slightly from those in the *Guidelines*. The model provisions present the concepts and methods of *Guidelines* Chapters 4 through 6. For clarity and brevity, the simplified evaluation equations of *Guidelines* Chapter 3 are not presented. Simplified evaluation per *Guidelines* Chapter 3, which is advantageous in certain circumstances but which yields conservative estimates of capacity and drift limit *POE*, could be accepted by a jurisdiction as an alternative to model code Sections 4, 5, and 6 below.

CHAPTER 1. SEISMIC EVALUATION AND RETROFIT OF WEAK-STORY DEFICIENCIES IN MULTI-UNIT WOOD-FRAME RESIDENTIAL BUILDINGS

SECTION 1. GENERAL

1.1 Intent. The intent of this chapter is to promote public welfare and safety through earthquake risk reduction measures in certain buildings. The provisions provide a means for identifying and quantifying weak-story conditions that represent an unacceptable risk of collapse. The provisions also provide a means for quantifying the strength of retrofit elements installed only within the first story.

CI.1. These model provisions are based on FEMA P-807, Seismic Evaluation and Retrofit of Multi-Unit Wood-Frame Buildings With Weak First Stories, referred to here as the Guidelines. The provisions are technical; they do not include administrative provisions that are generally necessary to establish reporting requirements (other than construction documents), compliance schedules, fees and fines, or appeals processes. As discussed in Guidelines Appendix B, a mitigation program can be customized in terms of its phasing. The provisions support an evaluation phase and a retrofit phase but do not specify requirements or options for implementing or skipping phases. See also Section 1.3.

1.2 Performance Objective.

CI.2. This section includes four blanks to be filled in by the implementing jurisdiction. See Guidelines Sections 1.4.2 and Appendix B for discussion of effective performance objectives.

1.2.1 Hazard level. The spectral demand shall be the site-adjusted short-period spectral acceleration corresponding to the site-specific _____ hazard level.

CI.2.1 The implementing jurisdiction should complete or edit Section 1.2.1 as needed to describe the selected earthquake hazard level. Any hazard level may be specified. Possibilities include the Maximum Considered Earthquake (MCE), which is the theoretical basis for code-based design of new buildings, some fraction of the MCE, such as the

*2/3*MCE value used by various engineering criteria, or probabilistically-defined events such as those used by ASCE 41-13. “Site-adjusted” refers to techniques that account for site class or soil profile type, such as building code provisions that modify mapped acceleration values.*

1.2.2 Performance level. Acceptable performance shall be based on drifts corresponding to the onset of strength loss in the seismic force-resisting wood-frame elements.

CI.2.2. Criteria for “onset of strength loss” are embedded in the criteria provided here. See Guidelines Section 1.4 and Chapter 7 for discussion of alternate performance levels.

1.2.3 Desired drift limit probability of exceedance. The drift limit *POE* for evaluation shall be ____ percent. The drift limit *POE* for retrofit design shall be ____ percent.

1.2.4 Acceptable drift limit probability of exceedance for optimized retrofit. The maximum acceptable probability of exceedance for optimized first-story retrofit designs shall be ____ percent.

CI.2.4. See Guidelines Section 6.2.2 for additional discussion.

1.3 Required scope of work. Compliance with the provisions of this chapter requires either:

1. Demonstration of an acceptable existing condition per Section 6, including correction of all aspects of eligibility or building survey non-compliance.
2. Design and execution of a retrofit in accordance with Sections 7 and 8 and with other applicable codes and regulations, including correction of all aspects of eligibility or building survey non-compliance.

*CI.3. Guidelines Appendix B discusses options for a phased mitigation program. These model provisions support an evaluation phase and a retrofit phase. (They do not support a screening phase per se, though one could be implemented by appropriate selection of the evaluation drift limit *POE*.) Programs that would give options to skip certain phases might need additional administrative provisions.*

1.4 Limitations. These evaluation and retrofit provisions are related to the onset of strength loss in wood-frame elements of the seismic force-resisting system, a condition that indicates a substantially increased potential for structural collapse. As such, they might not be adequate for predicting the likelihood of other damage states. The retrofit provisions are premised on the assumption that work will be constrained to the first story and the second-floor diaphragm. As such, they do not necessarily provide a comprehensive retrofit to a stated performance objective. When followed, the retrofit provisions will improve performance, but they will not necessarily prevent damage or mitigate failure modes other than those related to weak-story conditions and associated torsion.

1.5 Coordination with other codes and standards. Compliance with these provisions does not necessarily satisfy the requirements of *International Building Code* Chapter 34 or the *International Existing Building Code* as they apply to certain additions, alterations, repairs, or changes of occupancy. Compliance with these provisions does not necessarily meet any performance level of ASCE/SEI 31-03, or any retrofit objective of ASCE/SEI 41-06, or ASCE/SEI 41-13 (in preparation).

SECTION 2. DEFINITIONS

2.1 Terminology. Terms used in these provisions shall have the meanings provided in this section. Terms not defined in this section shall have the meanings provided in the building code.

C2.1. In some instances, the notation and terminology differ slightly from those in the Guidelines.

CENTER OF STRENGTH. At each story, the location in plan that represents the weighted average location of the load in all wall lines, at the drift associated with the story strength.

DRIFT. For a given story, the calculated or postulated lateral deflection within that story divided by the story height, normally expressed as a percentage.

FIRST STORY. The story of interest with respect to weak-story evaluation or retrofit, spanning vertically between the first floor and the second floor.

LOAD-DRIFT CURVE. For a wall assembly, wall line, or story, the relationship characterizing the variation of shear resistance versus drift, for the full range of relevant drifts. For a wall assembly, the load value is given in units of force per unit length. For wall lines and stories, the load value is given in units of force.

LOAD-ROTATION CURVE. For a story, the relationship characterizing the variation of torsional resistance versus story rotation, for the full range of relevant rotations, given in units of torque as a function of rotation angle.

PROBABILITY OF EXCEEDANCE (POE). The desired or calculated probability that the structure will respond beyond the drift limits representing the desired performance level, in at least one direction, when subjected to a specified hazard level.

QUALIFYING WALL LINE. For purposes of checking eligibility of floor or roof diaphragms, a wall line that contributes to the peak story strength at least one third as much strength as the strongest parallel wall line in the same story and has an adequate load path to the diaphragms it affects.

C2.1, continued. See Guidelines Section 2.6.4 for discussion of rules for “qualifying” wall lines. The “one third” criterion is subject to judgment.

SPECTRAL CAPACITY. For a given drift limit probability of exceedance, the highest level of spectral acceleration a structure can sustain without responding beyond the drift limits representing the desired performance level, given as a multiple of the acceleration of gravity, and calculated separately in each principal direction.

SPECTRAL DEMAND. The site-adjusted short-period spectral acceleration corresponding to the specified earthquake hazard level, given as a multiple of the acceleration of gravity.

STORY STRENGTH. The maximum load value from the story load-drift curve, calculated separately in each principal direction.

STORY STRENGTH, BASE-NORMALIZED. The story strength divided by the total seismic weight of the building.

STORY STRENGTH, STORY-NORMALIZED. The story strength divided by the sum of the tributary floor weights of all the floors above the story in question.

STORY TORSIONAL STRENGTH. The maximum torsional resistance value from the story load-rotation curve.

STRENGTH DEGRADATION RATIO. In each direction, a value between 0.0 and 1.0 calculated as the first-story strength divided by the load corresponding to a drift of 3 percent from the first-story load-drift curve.

TORSION COEFFICIENT. A value that need not be taken greater than 1.4, calculated as the first-story torsional demand divided by the first-story torsional strength.

TORSIONAL ECCENTRICITY. The absolute value of the plan distance, in x and y components, between the second-story center of strength and the first-story center of strength.

TRIBUTARY FLOOR WEIGHT. The total seismically active weight tributary to a single floor level comprising dead load and applicable live load, snow weight, and other loads as required by the building code.

UPPER STORY. Any story above the first story.

WALL ASSEMBLY. A unique combination of sheathing materials over wood-stud framing.

WALL LINE. A collection of full-height and partial-height wall segments or frames within a single story that satisfies the rules in Section 5.1.2 and which is assumed to contribute strength only in the direction parallel to its length.

WALL SEGMENT. A portion of wood-frame wall made from a single wall assembly. For purposes of this definition, any sheathed run of wood-stud framing that could contribute to a story's lateral strength or stiffness shall be considered a potential wall segment, whether or not the framing and sheathing were intentionally designed, detailed, sized, or located to contribute that strength or stiffness.

2.2 Notation.

C2.2. In some instances, the notation and terminology differ slightly from those in the Guidelines.

A_U	The base-normalized upper-story strength, calculated separately for each direction.
A_W	The weak-story ratio, calculated separately for each direction.
C_D	The strength degradation ratio, calculated separately for each direction.
C_T	The torsion coefficient.
C_U	The minimum of the story-normalized story strengths of any of the upper stories, calculated separately for each direction.

COS_i	The plan location, in x and y coordinates, of the center of strength of story i .
e_x, e_y	The x and y components, respectively, of the torsional eccentricity.
f_w	The load-drift curve for wall line w .
F_i	The load-drift curve for story i , calculated separately for each direction.
h_w	The floor-to-ceiling height of wall line w .
H_I	The floor-to-ceiling height of the tallest first-story wall line, determined separately in each direction.
i	A subscript index indicating floor or story. Story i is between floor i and floor $i+1$.
L_w	The length of wall line w , taken as the longest possible length of wall that satisfies the rules in Section 5.1.2, including the length of any openings within it.
L_x	The overall building dimension in the x direction.
L_y	The overall building dimension in the y direction.
POE	Probability of Exceedance, as used extensively in the phrase, “drift limit POE ” (i.e., drift limit Probability of Exceedance)
Q_{open}	The adjustment factor for openings in a wall line.
Q_{ot}	The adjustment factor for overturning of a wall line.
Q_s	The story height factor for the first story, calculated separately for each principal direction.
S_c	The spectral capacity, calculated separately for each direction.
S_d	The spectral demand.
t_i	The load-rotation curve for story i .
T_i	The story torsional strength of story i .
V_{I_r}	The story strength of the retrofitted first story, calculated separately for each direction.
V_i	The story strength of story i , calculated separately for each direction.

V_U	The story strength of the upper story that determines the value of C_U .
w	A subscript index indicating a single wall line.
W	The total seismic weight of the building, equal to the sum of all the tributary floor weights.
W_i	The tributary floor weight of floor i .
WSP	Wood structural panel
x	A subscript index indicating one of two principal directions.
$\alpha_{POE,0}$	The drift limit probability of exceedance (POE) adjustment factor for a C_D value of 0.0.
$\alpha_{POE,1}$	The drift limit probability of exceedance (POE) adjustment factor for a C_D value of 1.0.
Δ_i	In each direction, the drift at which the story strength of story i occurs.
τ_1	The first-story torsional demand.

SECTION 3. ELIGIBILITY

3.1 General. Buildings that do not comply with the requirements of this section are not eligible for the procedures in this chapter.

Exception: Buildings in which all aspects of non-compliance with the requirements of this section will be eliminated through alteration or retrofit are eligible for the procedures in this chapter.

3.1.1 Massing.

1. The building is no taller than four stories above grade at any point around its perimeter.
2. The building's wood-framed stories are not supported by an above-grade podium structure.

3.1.2 Upper stories.

1. The upper-story seismic force-resisting systems are bearing wall or building frame systems of wood-frame walls with shear panels.
2. The upper-story floor-to-floor heights are between 8 feet and 12 feet and are constant within each story.

3. In each upper story, in each principal direction, the distance from the center of strength to the center of mass of the floor below it is no more than 25 percent of the corresponding building dimension.

C3.1.2 The intent of this approximate rule is to ensure that no upper story is prone to significant torsion, and that inertial forces from upper stories should transfer to the first story near the geometric center of the second floor. See Guidelines Section 2.6.2.

4. No upper story or floor above an upper story has a weight irregularity as defined by ASCE/SEI 7-05 Table 12.3-2, Type 2.
5. No upper story has a vertical geometric irregularity as defined by ASCE/SEI 7-05 Table 12.3-2, Type 3.

3.1.3 First story, basement and foundation.

1. The first-story height may vary, but the maximum first-story height, from top of foundation to top of second-floor framing is between 8 feet and 15 feet.
2. The first-story seismic force-resisting systems are bearing wall or building frame systems of wood-frame walls with shear panels or combine such systems with steel moment-resisting frame systems or steel buckling-restrained braced frame systems.

C3.1.3. Ordinary or special concentrically braced frames, concrete shear walls, and reinforced masonry shear walls are not suitable retrofit elements under the Guidelines. See Guidelines Section 6.5.

3. The first story includes no full-height concrete or masonry walls.
4. The first-story walls and frames have continuous concrete footings or concrete slab-on-grade foundations. If some or all of the first floor is raised over a crawl space, the crawl space has concrete stem walls to the underside of the first-floor framing.

C3.1.3, continued. Concrete stem walls are considered to provide a base similar to a concrete foundation. Wood-framed cripple walls, whether braced or unbraced by sheathing of any type, are not adequate to meet this provision..

5. First-story walls and frames may be partial height over a concrete or reinforced masonry retaining wall or foundation stem wall, but any

partial-height wall or frame is at least four feet tall from top of stem wall to underside of second-floor framing.

6. If the building has a basement, the basement walls and the floor diaphragm just above them are capable of transferring seismic forces between the foundation and the first story, and the basement story is laterally stronger than the first story above it.

3.1.4 Floor and roof diaphragms.

C3.1.4. The intent of these approximate rules for diaphragms is to ensure that the structure does not develop a premature mechanism or failure mode. See Guidelines Section 2.6.4 for additional explanation and guidance.

1. No portion of the second-floor diaphragm between qualifying wall lines has an aspect ratio greater than 2:1.
2. The second-floor diaphragm does not cantilever more than 25 feet from a qualifying wall line.
3. If the second-floor diaphragm cantilevers more than 10 feet from a qualifying wall line, diaphragm chords are adequate to develop the lesser of the strength of the diaphragm or the diaphragm forces associated with the peak strength of the qualifying wall line.
4. No floor or roof diaphragm has a reentrant corner irregularity in which either projecting leg of the diaphragm beyond the reentrant corner is longer than 15 percent of the corresponding plan dimension of the building, unless each leg of the diaphragm satisfies the aspect ratio and cantilever rules of this subsection.

C3.1.4, continued. This provision differs from the irregularity defined in ASCE/SEI 31-03 or as Type 2 in ASCE/SEI 7-05 Table 12.3-1 in order to limit diaphragm demands. See Guidelines Section 2.6.4.

5. No floor or roof diaphragm has a vertical offset unless load path components are present and adequate to develop the diaphragm strength across the offset.
6. No floor or roof diaphragm has cutouts or openings within it such that, along any line across the diaphragm, the sum of the opening widths along that line is more than 25 percent of the overall diaphragm dimension along that line.

Exception: Diaphragms shown to have no deficiencies or irregularities that would prevent development of the strength of any seismic force-resisting wall or frame or would otherwise control the overall seismic response of the structure need not satisfy the eligibility requirements in this subsection.

SECTION 4. BUILDING SURVEY

4.1 General. Structural components shall be investigated in accordance with this section, as needed to confirm eligibility per Section 3 and to support structure characterization per Section 5, evaluation per Section 6, and retrofit design per Section 7.

4.2 Building investigation and documentation. The owner shall conduct or cause to be conducted an investigation of the existing building. The engineer of record shall prepare a written report documenting procedures, findings, and relevant conclusions of the investigation. The report shall reference calculations or other documents submitted to demonstrate compliance with this chapter. The code official is authorized to require additional investigation as needed to fulfill the purpose of the report and the intent of this chapter.

With respect to evaluation, the primary purpose of the investigation is to identify or confirm the nature of the existing construction as needed to justify load drift curves and tributary floor weights. A secondary purpose is to provide condition assessment sufficient to rule out deterioration or construction defects significant enough to affect earthquake performance of the structure as a whole.

With respect to retrofit design, the primary purpose of the investigation is to confirm design assumptions regarding the adequacy of existing seismic load path components within the context of the retrofitted structure. With the approval of the code official, field verification of assumed conditions may be performed during the construction phase.

4.2.1 Sources of information. The investigation shall be based on a combination of non-destructive testing or inspection, destructive testing or inspection, and reference to record documents. Where record documents are used to reduce the scope of testing or other on-site work, appropriate field verification is required.

4.2.2 Wall framing and sheathing. The investigation shall determine the length and location in plan of all wall segments and wall lines in all stories as needed to calculate load-drift curves.

The investigation shall determine the size and location of openings in each wall line as needed to calculate adjustment factors for openings and adjustment factors for overturning.

The investigation shall determine all unique frames or wall assemblies in the first story and representative wall assemblies in the upper stories. Where sheathing includes wood structural panel or where sheathing load-drift data is a function of nailing, the investigation shall also determine the nail size and edge nail spacing.

4.2.3 Floor and roof framing and diaphragm. The investigation shall determine the construction of floor and roof framing and diaphragm sheathing, including the direction of framing and the mechanism of gravity load transfer, as needed for calculation of adjustment factors for overturning. The second floor shall be investigated. Subject to approval of the code official, the roof and upper floors need not be investigated in detail where there is evidence that their relevant attributes are similar to those of the second floor.

4.2.4 Load path components. The investigation shall determine the nature of the load-path components and connections for transfer of forces between the second-floor diaphragm and first-story walls and frames as needed to confirm that the wall line will participate in resisting drift.

C4.2.4. For non-WSP sheathing, the intent is to confirm that fastening reasonably conforms to conventional construction requirements. For existing WSP shear walls with nail spacing closer than six inches, it should be confirmed at representative locations that shear wall top and bottom connection capacity is reasonably in balance with the sheathing capacity.

The investigation shall determine the presence or absence of hold-down hardware at the base of all first-story walls, as well as the adequacy of installation of representative types at representative locations.

The investigation shall confirm that anchor bolts are provided at the base of the first-story walls.

4.2.5 Condition assessment. The investigation shall seek evidence of damage, deterioration, or defective construction sufficient to affect significantly the performance of the seismic force-resisting system. All investigations performed in this regard shall be documented.

SECTION 5. STRUCTURE CHARACTERIZATION

5.1 Story strength.

5.1.1 Wall assemblies. For each wall assembly present, a load-drift curve shall be computed by summing contributions from Table 5.1.1 at each drift level for each layer of sheathing. With approval of the code official, test results specific to the wall assembly or its components may be used in place of Table 5.1.1. Sheathing layers or wall assemblies considered to have significant damage, deterioration, or construction defects shall have their load-drift strength values reduced.

C5.1.1 See Guidelines Section 4.4 and Appendix F regarding the development of Table 5.1.1 and the use of alternate test data.

Table 5.1.1. Load-Drift Curve Data [plf]

Sheathing Material ¹	Drift, δ [%]								
	0.5	0.7	1.0	1.5	2.0	2.5	3.0	4.0	5.0
Stucco	333	320	262	0	--	--	--	--	--
Horizontal wood sheathing or wood siding	85	96	110	132	145	157	171	0	--
Diagonal wood sheathing	429	540	686	913	0	--	--	--	--
Plaster on wood lath	440	538	414	391	0	--	--	--	--
Plywood panel siding	354	420	496	549	565	505	449	0	--
Gypsum wallboard	202	213	204	185	172	151	145	107	0
Plaster on gypsum lath	402	347	304	0	--	--	--	--	--
WSP, 8d@6	521	621	732	812	836	745	686	0	--
WSP, 8d@4	513	684	826	943	1,018	1,080	1,112	798	0
WSP, 8d@3	1,072	1,195	1,318	1,482	1,612	1,664	1,686	1,638	0
WSP, 8d@2	1,393	1,553	1,713	1,926	2,096	2,163	2,192	2,130	0
WSP, 10d@6	548	767	946	1,023	1,038	1,055	1,065	843	0
WSP, 10d@4	707	990	1,275	1,420	1,466	1,496	1,496	1,185	0
WSP, 10d@3	940	1,316	1,696	1,889	1,949	1,990	1,990	1,576	0
WSP, 10d@2	1,120	1,568	1,999	2,248	2,405	2,512	2,512	2,231	0

¹ WSP = wood structural panel sheathing

5.1.1.1 Wall assemblies without wood structural panel sheathing. The assembly load drift curve is the sum of the load drift curves for each of the sheathing layers.

5.1.1.1 Wall assemblies with wood structural panel sheathing. The assembly load drift curve is whichever of the following two load-drift curves has the larger peak strength:

1. The assembly load-drift curve using 50 percent of the strength of the wood structural panel layers and 100 percent of the strength of the other sheathing materials.
2. The assembly load-drift curve using 100 percent of the strength of the wood structural panel layers and 50 percent of the strength of the other sheathing materials.

5.1.2 Wall line assignment. Each segment of sheathed wall framing within a story shall be assigned to a wall line. Wall lines shall satisfy the following rules:

1. Full-height wall segments separated by window or door openings but connected by sheathed segments and continuous framing above or below the opening shall be assigned to the same wall line, unless other rules require them to be treated separately.
2. Wall segments assigned to the same wall line shall not be offset out-of-plane from adjacent segments by more than four feet.
3. At bay windows, the wall segments within the common plane shall be assigned to the same wall line if they satisfy the other rules, but the wall segments within the cantilevered portions of the bay shall not be counted toward the wall-line strength.
4. Wall segments of different heights, including wall segments along a stepped foundation, shall be assigned to separate wall lines.
5. A wall segment of varying height due to a sloped foundation shall be assigned to a separate wall line, and its height shall be taken as the average height of the segment.
6. Wall segments of different wall assemblies shall be assigned to separate wall lines.
7. Where hold-downs exist at each end of a wall segment, that segment may be considered a separate wall line.
8. Wall segments less than one foot long shall be treated as openings.

9. Wall segments between openings with height-to-length ratios greater than 8:1 shall be treated as openings.
10. Steel moment frames shall be assigned to separate wall lines.
11. Wall segments or frames considered to have significant damage, deterioration, or construction defects may be counted toward a wall line's strength but shall have their load-drift strength values reduced.

5.1.3 Wall line load-drift curve. For each wall line, a load-drift curve shall be computed by multiplying the applicable wall assembly load-drift curve by the wall line's length and by applicable adjustment factors per Equation 5.1.3-1.

$$f_w = (v_w)(L_w)(Q_{open})(Q_{ot}) \quad (\text{Equation 5.1.3-1})$$

where:

f_w is the load-drift curve of wall line w , expressed as a function of drift.

v_w is the load-drift curve of the wall assembly associated with wall line w , as derived per Section 5.1.1 and adjusted for height variation per Section 5.1.3.1.

5.1.3.1 Adjustment for height variation. Where first-story wall lines in a given direction are of different heights, the load-drift curve of the wall assembly of each wood-frame wall line shall be adjusted to account for increased drift demands in all but the tallest first-story wall line. This may be done by shifting the assembly load-drift curve from the standard set of drifts given in Table 5.1.1 to an adjusted set of drifts for each wall line, given by Equation 5.1.3.1-1.

$$\delta_{jh} = (\delta_j)(h_w/H_1)^{0.7} \quad (\text{Equation 5.1.3.1-1})$$

5.1.3.2 Adjustment for openings. Each wall line load-drift curve shall account for the effects of openings within it. This may be done by applying the adjustment factor for openings, given by Equation 5.1.3.2-1 and Equation 5.1.3.2-2.

$$Q_{open} = 0.92a - 0.72a^2 + 0.80a^3 \quad (\text{Equation 5.1.3.2-1})$$

$$a = \frac{1}{\left(1 + \frac{\sum A_o}{h_w \sum L_f}\right)} \quad (\text{Equation 5.1.3.2-2})$$

where:

$\sum A_o$ = sum of the areas of the openings within the wall line

$\sum L_f$ = sum of the lengths of the full-height wall segments within the wall line

5.1.3.3 Adjustment for overturning. Each wall line load-drift curve shall account for the effects of overturning demand and resistance. This may be done by applying the adjustment factor for overturning, given by Equation 5.1.3.3-1 or, for existing upper-story wall lines only, by Table 5.1.3.3.

$$Q_{ot} = 0.4 \left(1 + 1.5 \frac{M_r}{M_{ot}} \right) \leq 1.0 \quad \text{(Equation 5.1.3.3-1)}$$

where M_{ot} is the overturning demand on the wall line due to the peak strengths of wall lines in the stories above, adjusted themselves for openings and overturning, and M_r is the resisting moment due to all available dead loads tributary to the wall line plus the effects of any tie-down hardware.

C5.1.3.3. See Guidelines Section 4.5.3.2 for guidance on calculating Q_{ot} .

Table 5.1.3.3. Default Adjustment Factor for Overturning, Q_{ot} , for Existing Upper-story Wall Lines

Number of Stories Above	Perpendicular to Framing	Parallel to Framing	Unknown or Mixed
Two or more	0.95	0.85	0.85
One	0.85	0.80	0.80
None (Top story)	0.75	0.75	0.75

5.1.4 Story load-drift curves. For each story, in each direction, a load-drift curve shall be computed by adding the load-drift curves of all the walls in that story and aligned in that direction.

C5.1.4. Where all the wall line load-drift curves are mapped to the same set of drifts, the summation is straightforward. Where some first-story wall lines have load-drift curves mapped to a height-adjusted set of drifts, load values at the standard drift values should be determined by linear interpolation. Once interpolated values are calculated, the various load-drift curves can again be added in a straightforward way based on the

standard drift values. See Guidelines Section 4.6 for additional discussion.

5.2 First-story torsion.

5.2.1 Center of strength. The center of strength for the first and second stories shall be determined based on the wall line loads at the drift at which the story strength in the corresponding story and direction occurs.

C5.2.1. Guidelines Section 4.6.4 illustrates the calculation of the center of strength.

5.2.2 First-story torsional demand. The first-story torsional demand represents the effect of the first-story strength acting at the torsional eccentricity, given by Equation 5.2.2-1.

$$\tau_T = e_x V_{Iy} + e_y V_{Ix} \quad (\text{Equation 5.2.2-1})$$

5.2.3 First-story load-rotation curve. For the first story, a load-rotation curve shall be derived, relating torsion about the story center of strength to the resulting rotation of the story, assuming a rigid second-floor diaphragm and accounting for the load-drift behavior of each first-story wall line. The load-rotation curve shall consider rotation angles up to at least the rotation associated with 5 percent in-plane drift in at least one first-story wall line.

C5.2.3. Guidelines Section 4.6.6 illustrates the calculation of the load-rotation curve, dividing the rotation range of interest into ten even increments.

5.3 Characteristic coefficients.

5.3.1 Base-normalized upper-story strength. The base-normalized upper-story strength shall be calculated for each principal direction per Equation 5.3.1-1.

$$A_U = \frac{V_U}{W} \quad (\text{Equation 5.3.1-1})$$

C5.3.1. In typical regular buildings, the story strengths are roughly the same in all the upper stories, and the seismic weight is greater toward the lower stories, so V_U is usually the second-story strength.

5.3.2 Weak-story ratio. The weak-story ratio shall be calculated for each principal direction per Equation 5.3.2-1.

$$A_w = \frac{V_1}{V_U} \quad (\text{Equation 5.3.2-1})$$

C5.3.2. *In typical regular buildings, the story strengths are roughly the same in all the upper stories, and the seismic weight is greater toward the lower stories, so V_U is usually the second-story strength.*

5.3.3 Strength degradation ratio. The strength degradation ratio, C_D , shall be calculated for each principal direction based on the first-story load-drift curves.

C5.3.3. *Guidelines Section 4.7.4 illustrates the calculation of the strength degradation ratio.*

5.3.4 Torsion coefficient. The torsion coefficient, given by Equation 5.3.4-1, need not be taken greater than 1.4.

$$C_T = \frac{\tau_1}{T_1} \quad (\text{Equation 5.3.4-1})$$

5.3.5 Story height factor. The story height factor shall be calculated for each principal direction per Equation 5.3.5-1, where H_1 is given in inches.

$$Q_s = 0.55 + 0.0047 H_1 \quad (\text{Equation 5.3.5-1})$$

SECTION 6. EVALUATION

6.1 Evaluation relative to the performance objective. Subject to the additional requirements of Section 1.3, any eligible structure shall be deemed to comply with the requirements of this Chapter if its spectral capacity in each principal direction exceeds the spectral demand.

6.1.1 Spectral capacity. Spectral capacity in each direction shall be calculated from Equations 6.1.1-1 through 6.1.1-5, using drift limit *POE* adjustment factors given in Table 6.1.1 for the drift limit *POE* specified in Section 1.2. Drift limit *POE* adjustment factors for intermediate values of drift limit *POE* shall be calculated by linear interpolation.

$$S_c = C_D^3 S_{c1} + (1 - C_D^3) S_{c0} \quad (\text{Equation 6.1.1-1})$$

$$S_{c1} = \alpha_{POE,1} S_{\mu 1} \quad (\text{Equation 6.1.1-2})$$

$$S_{c0} = \alpha_{POE,0} S_{\mu 0} \quad (\text{Equation 6.1.1-3})$$

$$S_{\mu 1} = (0.525 + 2.24 A_w) (1 - 0.5 C_T) Q_s A_U^{0.48} \quad (\text{Equation 6.1.1-4})$$

$$S_{\mu 0} = (0.122 + 1.59A_w)(1 - 0.5C_T)Q_s A_U^{0.60} \quad (\text{Equation 6.1.1-5})$$

Table 6.1.1. Drift Limit Probability of Exceedance Adjustment Factors.

POE	$\alpha_{POE,1}$	$\alpha_{POE,0}$
2%	0.36	0.29
5%	0.44	0.37
10%	0.53	0.46
20%	0.66	0.60
50%	1.00	1.00
60%	1.14	1.16
70%	1.30	1.37
80%	1.52	1.66

6.2 Calculated drift limit POE. Given a spectral demand, the drift limit *POE* of a structure, where required, shall be calculated for each principal direction using Equations 6.2-1 and 6.2-2. For intermediate values of C_D , the value of the drift limit *POE* shall be estimated by linear interpolation between the two calculated values. The drift limit *POE* shall be calculated for each principal direction, and the smaller value shall be taken as the drift limit *POE* value for the structure.

$$POE_1 = 84.0 \left(\frac{S_d}{S_\mu} - 0.41 \right) \quad \text{for } C_D = 1.0 \quad (\text{Equation 6.2-1})$$

$$POE_0 = 75.2 \left(\frac{S_d}{S_\mu} - 0.33 \right) \quad \text{for } C_D = 0.0 \quad (\text{Equation 6.2-2})$$

where S_μ is calculated by interpolating between the values given by Equations 6.1.1-4 and 6.1.1-5 for the actual value of C_D .

C6.2. Equations 6.2-1 and 6.2-2 are linear approximations that are valid when they give drift limit POE values between about 5 percent and 70 percent. See Guidelines Section 5.4.2, Chapter 7, and Appendix F when these equations indicate more extreme values of drift limit POE.

SECTION 7. RETROFIT

7.1 Retrofit requirements. Where required, retrofit designs shall meet the performance requirements of either Section 7.2 or Section 7.3, as well as the general compliance requirements of Section 1.3. If the requirements of neither Section 7.2 nor Section 7.3 can be met, the building shall be considered ineligible to use the provisions of this Chapter.

7.1.1 Retrofitted first-story strength. The first-story strength of the retrofitted structure shall account for all existing unaltered elements, existing altered elements, new elements provided to increase story strength, and new elements provided in accordance with Section 1.3 to correct aspects of eligibility or building survey non-compliance.

7.2 Retrofit to meet the performance objective. Any eligible retrofitted structure shall be deemed to comply with the performance requirements of this Chapter if both of the following conditions are true:

1. The retrofitted structure's spectral capacity in each principal direction exceeds the spectral demand.
2. The first-story strength of the retrofitted structure in each direction satisfies Equation 7.2-1.

$$V_r \leq 1.1V_U(0.11A_U + 1.22) \quad (\text{Equation 7.2-1})$$

C7.2. Guidelines Section 6.2.1 provides formulas for estimating the strength of the retrofitted first story needed to reach the required spectral capacity. Guidelines Sections 6.2.2 and 6.2.3 discuss the derivation and meaning of Equation 7.2-1.

7.3 Alternative retrofit to optimize first-story strength. Any eligible retrofitted structure shall be deemed to comply with the performance requirements of this Chapter if all of the following conditions are true:

1. The first-story strength of the retrofitted structure in each direction satisfies Equation 7.3-1.
2. The retrofit design satisfies the requirements of Section 7.3.1.
3. The retrofit design satisfies the requirements of Section 7.3.2.

$$0.9V_U(0.11A_U + 1.22) \leq V_r \leq 1.1V_U(0.11A_U + 1.22) \quad (\text{Equation 7.3-1})$$

7.3.1 Maximum acceptable drift limit POE. The drift limit *POE* of the retrofitted structure in each direction, calculated in accordance with Section

6.2, shall be less than the maximum acceptable drift limit *POE* stipulated in Section 1.2.4.

C7.3.1. See Guidelines Section 6.4.2 for discussion of the maximum acceptable POE for optimized first-story retrofits.

7.3.2 Minimized torsional eccentricity. Retrofit elements shall be located along perimeter wall lines so as to minimize the torsional eccentricity of the retrofitted structure, or so as to satisfy equations 7.3.2-1 and 7.3.2-2. This requirement may be waived with the approval of the code official to accommodate other building or planning code requirements or to avoid disproportionate construction costs.

$$e_x \leq 0.10L_x \quad (\text{Equation 7.3.2-1})$$

$$e_y \leq 0.10L_y \quad (\text{Equation 7.3.2-2})$$

C7.3.2. Guidelines Section 6.3.1 discusses the need to locate retrofit elements so as to minimize torsion.

7.4 Design criteria for retrofit elements. Retrofit elements shall conform to the following requirements.

C7.4. Consistent with the eligibility rules in Section 3.1.3, Ordinary or Special Concentrically Braced Frames, concrete shear walls, and reinforced masonry shear walls are not suitable retrofit elements under the Guidelines. See Guidelines Section 6.5.

1. Where wood-frame walls or steel frames are sized based on unit strengths from codes or standards, the full expected capacity, without strength reductions or resistance factors, shall be used.
2. The load-drift curve of each retrofit element type shall be based on expected material properties, including overstrength. The full expected capacity, without strength reduction or resistance factors, shall be used to calculate load-drift curves and peak strengths.
3. Each retrofit element shall be such that a load-drift curve based on similar elements alone would have a strength degradation ratio, C_D , greater than or equal to 0.8.
4. The load-drift curve of each retrofit element type shall be defined up to 5-percent interstory drift or as needed to fully characterize the retrofit design per Section 5.

5. Materials and systems for all retrofit elements shall be consistent with provisions of the building code for new construction. Detailing of retrofit wall and frame elements shall be consistent with that applied to special seismic force-resisting systems used in new construction for the corresponding occupancy and risk category.

C7.4, continued. While codes for existing buildings typically allow “like materials” for repairs and alterations (for example, see 2012 IBC Section 3401.4.2), the Guidelines presume that retrofit elements will be reliably ductile, so detailing is important. This is consistent with code provisions for voluntary seismic upgrade (for example, see 2012 IBC Section 3404.5 or 2012 IEBC Section 807.6).

6. Design criteria for load-path components and connections shall be appropriate to the performance objective and shall be based on the building code for new construction, ASCE/SEI 41-13, or principles of capacity design.

7.4.1 Wood structural panel shear walls. Load-drift curves for wood structural panel retrofit elements shall be calculated in accordance with Section 5. Existing shear walls modified by replacing sheathing materials or by adding supplemental wood structural panels shall be considered retrofit elements.

7.4.2 Steel moment frames. Steel retrofit elements that conform to the requirements of AISC 341-05 for Special Moment Frames or AISC 341-10 for Special Cantilevered Column systems shall be deemed to comply with the provision requiring a C_D value greater than or equal to 0.8.

C7.4.2. Guidelines Section 6.5.4 offers further guidance on characterizing and designing these elements.

7.4.3 Steel braced frames. Steel retrofit elements that conform to the requirements of AISC 341-05 for buckling-restrained braced frames should be deemed to comply with the provision requiring a C_D value greater than or equal to 0.8.

C7.4.3. Guidelines Section 6.5.5 offers further guidance on characterizing and designing these elements.

7.5 Design criteria for load path elements and components. The retrofit design shall confirm or provide a load path from the second-floor diaphragm through the first-story seismic force-resisting elements and their

foundations, to the supporting soils. The ultimate strength of load-path components shall be reduced with strength reduction factors as needed to ensure that the load-path elements are able to develop the strength and the intended mechanism of first-story wall and frame elements. Specific design criteria may be derived from principles of capacity design, from ASCE/SEI 41-13, or from building code provisions involving the overstrength factor, Ω_o .

7.5.1 Foundations and overturning. New foundation elements shall be provided as needed to resist bearing, sliding, and overturning forces associated with the retrofit elements acting at their strength. Connections and load-path components related to wall or frame overturning shall not assume any acting dead load except for the self-weight of the retrofit element unless the retrofit element incorporates existing gravity-load-carrying framing or unless the design and construction explicitly transfer existing dead load to the retrofit element. The weight of foundation elements may be considered if adequately connected.

7.5.2 Second-floor diaphragm. The second-floor diaphragm shall be strengthened as needed to ensure that expected forces can be transferred between the diaphragm and the first-story elements.

SECTION 8. QUALITY ASSURANCE

8.1 Construction documents. Construction documents shall show all information necessary for compliance review and shall accurately reflect the results of the engineering investigation and design. The documents shall include:

1. A statement that the retrofit was designed in compliance with this Chapter and in compliance with administrative requirements of the mitigation program.
2. A statement of the performance objective stipulated in Section 1.2, including the hazard level, the performance level, the desired drift limit *POE*, and, where calculated, the actual drift limit *POE*.
3. Where applicable, a statement regarding the compliance of the retrofit work with other applicable building or planning codes, including structural provisions of the building code for certain alteration projects.
4. Documentation of existing construction, including depictions of the second-floor diaphragm and framing, first-story walls and frames and their foundations, and any basement or crawlspace conditions.

5. A foundation plan, including proposed new elements and connections to existing elements.
6. A first-floor retrofit plan, showing the types and locations of shear walls or steel frames proposed to be altered or added as retrofit elements.
7. Where applicable, plans and details for strengthening the second-floor diaphragm.
8. A retrofit schedule, notes, and details specifying all wood-frame materials and their construction, including sheathing type and thickness; fastener type and spacing, including edge distance; hold-downs and anchor bolts; alteration or supplement of studs, sill plates, and other framing; and quality control measures such as flush nailing at the wood surface and limits on notching or penetrations.
9. A retrofit schedule, notes, and details specifying all steel materials and their construction, including bolts; shop and field welds; base plates and anchor bolts; and erection procedures and sequences.
10. Load path, collector, and other details as needed for construction of the intended seismic force-resisting system.
11. Scope of required field verification, structural observation, testing, and inspection.
12. Other work as required for compliance with applicable requirements for work on existing buildings.
13. Other information as required by the code official.

8.2 Construction quality assurance. All work shall comply with inspection and testing requirements of the building code as they apply to existing buildings and structures.

Appendix C

Example Calculations

This appendix illustrates the application of *Guidelines* Chapters 3 through 6. The topics illustrated are:

- C.1: Simplified Evaluation (Chapter 3)
- C.2: Structure Characterization and Evaluation (Chapters 4 and 5)
- C.3: Retrofit (Chapter 6)
- C.4: Torsion calculations (Chapters 3 and 4)

In general, the intention of these examples is to illustrate the *Guidelines*' new concepts and key points, not to show complete step-by-step calculations. The examples presume familiarity with certain provisions of ASCE/SEI 7-05 and the 2009 *International Building Code* (IBC).

Example Building. All of the examples reference the four-story apartment building shown in Figure C-1. The example building is typical of multi-unit buildings erected in San Francisco in the 1920s. For these examples, its properties are loosely based on Index Building 3 from San Francisco's Community Action Plan for Seismic Safety (ATC, 2009b).

Basic information for the four-story building is given in Table C-1. For purposes of these examples, some of the information is simplified relative to that of an actual building. Additional details are provided in the examples as needed.



Figure C-1 Street elevation of example building.

Table C-1 Example Building Properties

Location	San Francisco, near Geary and Arguello
Soil type	Site Class D (not near liquefiable soil)
First floor uses	Parking (garage), lobby/entryway, utility, storage
Upper floor uses	Two residential units per floor
Approximate plan area	2270 square feet, each floor
Overall depth of building	86.5 ft (long or x direction)
Overall width of building	30 ft (short or y direction)
Perimeter wall types	Plaster on wood lath, both sides, all stories
Interior wall types	Plaster on wood lath, both sides, all stories
Wall clear height	8 ft, all stories
Floor to floor height	9 ft, all stories
Diaphragm construction	Diagonal 1x sheathing, wood finish floor, plaster and wood lath ceiling below (no ceiling above parking area at underside of second floor)

Eligibility (Section 2.6). The example building is presumed to satisfy all of the limitations and eligibility requirements in Section 2.6, with the following proviso: *Guidelines* Section 2.6.4 requires an overall second-floor diaphragm aspect ratio no greater than 2:1. The building’s overall dimensions (86.5 ft by 30 ft) do not meet this restriction. However, per Section 2.6, the building may be deemed eligible for *Guidelines* procedures if modified or retrofitted to meet the eligibility rules. Therefore, these examples assume that qualifying walls will be confirmed or added on lines B, C, D, and/or E (see Figure C-2) as needed to allow the second floor to qualify. See Section C.4 for additional discussion.

This suggests an evaluation strategy for buildings with irregular or ineligible conditions: Skip the evaluation of the existing building, size and locate potential retrofit elements as needed to make the structure eligible, and evaluate the modified structure instead. While rational, for purposes of illustrating the *Guidelines*’ provisions as written, these examples evaluate the existing condition unmodified.

Performance Objective (Section 2.3.2). Unless noted otherwise, all of the examples use the *Guidelines*’ default performance objective with a 20 percent drift limit probability of exceedance (*POE*), as described in *Guidelines* Section 2.3. The objective is stated as: “80 percent confidence of not exceeding the drift limits associated with onset of strength loss, in a Maximum Considered Earthquake.”

C.1 Simplified Evaluation (Chapter 3)

Drift Limit POE Adjustment Factor (Section 3.2). The drift limit *POE* adjustment factor is taken from Table 3-1 based on the stated performance objective. For simplified evaluation, only $\alpha_{POE,0}$ is used. For the 20 percent drift limit *POE* used in these examples, the adjustment factor is 0.60.

Building Survey (Section 3.3). *Guidelines* Chapter 3 calls for a detailed survey of the first story and a limited survey of the upper stories. The first floor plan of the example building is shown in Figure C-2. Since it is assumed that no drawings are available, dimensions are based on field measurements.

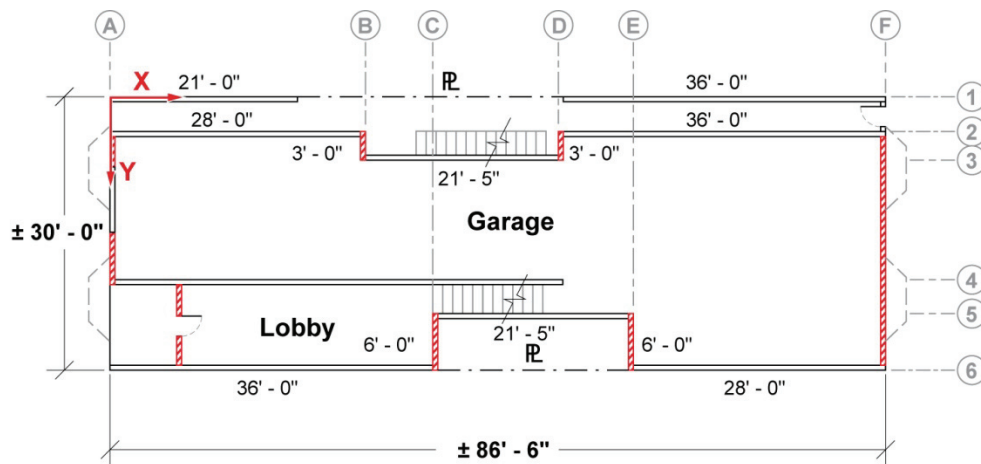

Figure C-2 Example building first-floor plan.

Figure C-2 shows all the walls conforming to *Guidelines* Section 3.3.1—those that are full height within the story, longer than two feet, not excessively narrow, structurally connected, and not deteriorated. As noted in Table C-1, all the walls are assumed (for the simplicity of this example) to be of the same construction, sheathed with wood lath and plaster on both sides.

For the upper stories, Section 3.3.2 does not require detailed wall measurements or characterization. Survey data are needed only to calculate the weight and to estimate the center of strength. From visual observation, the many upper-story walls are well distributed and roughly symmetrical in both directions, so the center of strength is assumed to be at about the geometric center of the second floor.

Though it does not affect the evaluation, it is worth noting that the upper story interior walls generally do not align in plan with the first-story walls. In fact, the first story has far fewer walls in the short direction than the upper

story, already suggesting the presence of a weak story in the short direction. (See example C.2 for more details of the upper story walls.)

Total Building Weight (Section 3.4.1). The simplified evaluation requires an estimate of the seismically active weight, W , based on conventional assumptions. Appropriate unit weights are not addressed by the *Guidelines* and are normally established through convention, experience, and judgment, if not stipulated by local regulations. For this building example, the total weight tributary to each floor level is shown in Table C-2.

Table C-2 Example Building Weights

Level	Area (Sq.ft.)	Long Dir'n Wall Length (ft)	Short Dir'n Wall Length (ft)	W (kips)	ΣW above (kips)
Roof	~2270	~280	~150 below	83	
4th Floor	~2270	~280	~150	122	83
3rd Floor	~2270	~280	~150	122	205
2nd Floor	~2300	~280	~150 above, ~55 below	111	327
Total				438	438

Shear Strength of First-Story Walls (Section 3.4.2). For simplified evaluation, the unit strength of each first-story wall assembly is calculated (per Equation 3-1) as the sum of the peak strengths of its sheathing layers. For this example, only one wall assembly is considered (see Table C-1). From Table 3-2, “plaster on wood lath” has a strength of 540 plf. Thus, with sheathing on both sides, the unit strength of the wall assembly is:

$$v_{a,w} = 2 \times 540 \text{ plf} = 1080 \text{ plf}$$

Guidelines Chapter 4 accounts for openings within a wall line. The simplified evaluation of Chapter 3, however, considers only the full-height wall segments. The total shear strength of each full-height wall segment (per Equation 3-2) is simply its length multiplied by its unit strength. (Typically, this calculation involves a tabulation of dimensions and unit strengths for each wall segment. For this example, however, because only a single wall type is used, the calculation is trivial and not shown.)

Shear Strength of First Story (Section 3.4.3). The first-story strength in each direction (per Equation 3-3), is the sum of the strengths of all the wall segments in that direction. For this example, because only a single wall type

is used, the strength may be calculated as the total wall length multiplied by the unit strength of 1080 plf:

$$V_{I,x} = 280 \text{ ft} \times 1080 \text{ plf} = 302 \text{ k, in the long or } x \text{ direction.}$$

$$V_{I,y} = 55 \text{ ft} \times 1080 \text{ plf} = 59 \text{ k, in the short or } y \text{ direction.}$$

Centers of Strength and Torsion (Sections 3.4.4 through 3.4.7). The simplified evaluation accounts for potential torsion in the first story. While the calculation is not difficult, it does involve some tedious bookkeeping (especially where many wall segments and wall assemblies are involved), so an initial check ignoring torsional effects is often practical.

Ignoring torsional effects means assuming the first-story center of strength is directly below the upper-story center of strength, so that the eccentricities (Equation 3-5) and the simplified torsion coefficient (Equation 3-6) are all zero.

This, of course, is an unconservative assumption, but it offers a useful shortcut. If the building fails the simplified evaluation under this assumption, then it would certainly have failed the simplified evaluation with non-zero torsion. Where this is the case, a full accounting for torsion is moot and need not be done. Nevertheless, the *Guidelines*' torsion provisions are illustrated and discussed in Section C.4 of this appendix.

Site-specific Spectral Acceleration Demand (Section 3.5.1). The performance objective for this example sets the demand as the Maximum Considered Earthquake (MCE), defined in ASCE/SEI 7-05. Per *Guidelines* Sections 3.5.1 and 5.4.1, the short-period spectral acceleration is used to represent demand. For the MCE, the demand is thus given by the ASCE/SEI 7-05 term S_{MS} .

Following the provisions of ASCE/SEI 7-05, S_{MS} for the example site and soil profile (see Table C-1) is 1.53g.

Story Height Factor (Section 3.5.2). The story height factor, explained in Section 4.7.6, normalizes the first-story strength to that associated with an 8-ft first story. In this example, the first-story height is 8 ft, or 96 in, so the factor calculates (per Equation 3-7) as expected:

$$Q_s = 0.55 + 0.0047(96) = 1.0$$

Simplified Spectral Acceleration Capacity (Section 3.5.3). The simplified spectral acceleration capacity is calculated for each direction with Equation 3-8:

$$S_{cs,x} = \alpha_{POE,0} (1.47 - 0.73C_{Ts}) Q_s \left(\frac{V_{l,x}}{W} \right)^{0.6}$$

Substituting values derived above,

$$S_{cs} = (0.60) [1.47 - 0.73 (0, \text{assumed})] (1.0) (V_l / 438 \text{ k})^{0.6}$$

In the long x direction, $V_{l,x} = 302 \text{ k}$, and $S_{cs,x} = 0.71\text{g}$.

In the short y direction, $V_{l,y} = 59 \text{ k}$, and $S_{cs,y} = 0.26\text{g}$.

Evaluation (Section 3.5.4). The capacity in each direction is less than the demand, $S_{ms} = 1.53\text{g}$, so the building fails the simplified evaluation.

For this example, the building fails the evaluation even with the initial unconservative assumption of zero torsion. Had the building passed, the evaluation would have to be redone with torsion considered.

Remarks. Table C-3 compares the building's capacity as calculated above with its capacity as calculated by a full evaluation (Section C.2). The calculations in Sections C.1 and C.2 both ignore torsion in order to focus on other points. The effects of torsion, calculated and discussed in Section C.4, are also shown here.

Table C-3 Example Building Spectral Capacity Calculated in Various Ways

Evaluation Method	Torsion Ignored	Torsion Considered
Capacity in long x direction		
Simplified evaluation (Sections C.1, C.4)	0.71g	0.61g
Full evaluation (Sections C.2, C.4)	0.80g	0.70g
Capacity in short y direction		
Simplified evaluation (Sections C.1, C.4)	0.26g	0.23g
Full evaluation (Sections C.2, C.4)	0.24g	0.21g

Results from a single example building do not reveal a general trend. Still it is noteworthy that even in this midblock building, which is not expected to have high torsion, the *Guidelines'* torsion provisions can significantly reduce the calculated capacity. (Also interesting is the finding that for the short direction, the simplified evaluation, which is supposed to be more conservative, results in a higher capacity than the full evaluation. This is an aberration, however, due to the full evaluation counting only full-height wall panels, not full wall lines with openings. This simplistic approach underestimates the story strength.)

C.2 Structure Characterization and Evaluation (Chapters 4 and 5)

This example illustrates the full evaluation procedure of *Guidelines* Chapters 4 and 5, as opposed to the simplified evaluation of Chapter 3. Figure C-3 shows the same first story wall layout as Figure C-2, with additional dimensions. Figure C-4 shows similar information for the typical upper stories. In both figures, the dimension strings show cumulative distance from the origin (at the top left of the figure); this information will prove useful in calculating eccentricities and torsional properties in example C.4.

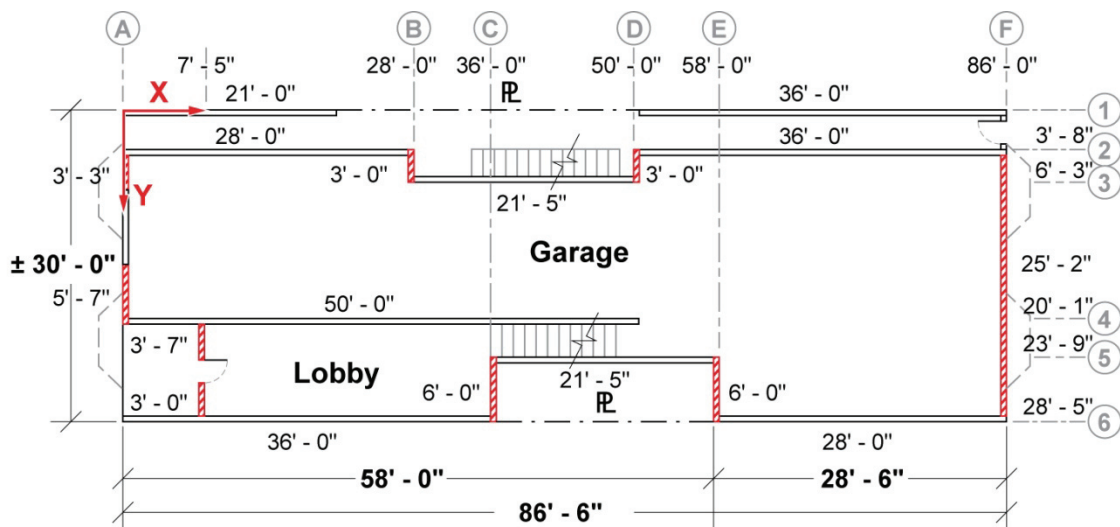

Figure C-3 Example building first-story wall lengths and locations.

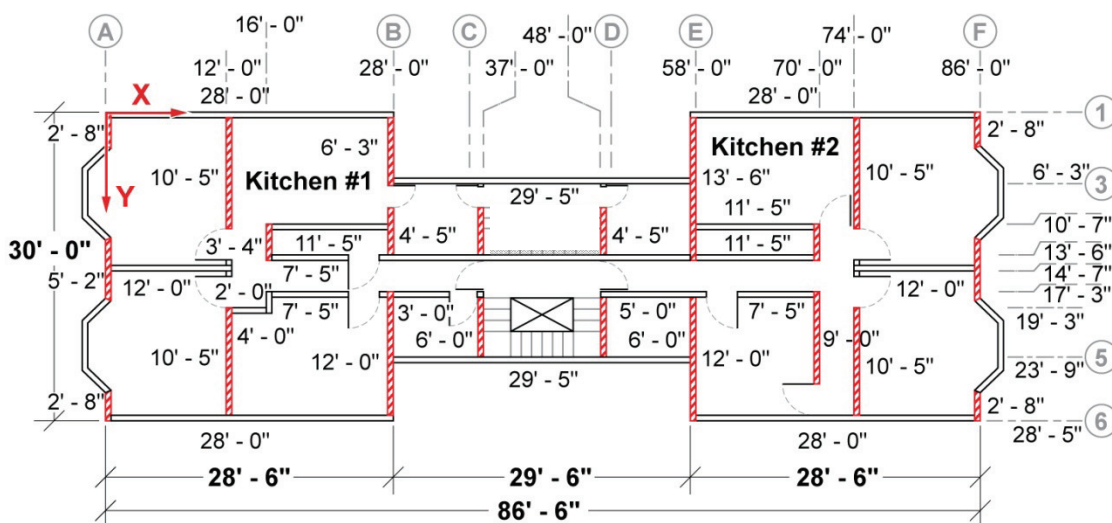

Figure C-4 Example building upper-story wall lengths and locations.

Load-Drift Curves (Section 4.4). Table 4-1 provides load drift curves for a variety of sheathing materials over a range of interstory drift ratios. Because this example uses only one wall type, the *Guidelines* rules for combining sheathing materials are not needed, and wall strength can be calculated by simply multiplying each wall's length by its peak unit strength. For plaster over wood lath, the peak unit strength of 1076 plf (538 plf each side) occurs at a drift of 0.7%.

Note also that for plaster and wood lath, the load-drift curve falls to zero at a drift of just 2.0%.

Translational Story Strength and Characteristic Coefficients (Sections 4.6 and 4.7). *Guidelines* Chapter 4 provides a complete set of rules for deriving story strengths while accounting for wall openings, overturning, variable wall heights, and torsion. The purpose of this example, however, is merely to illustrate the characteristic coefficients and the capacity equation. Therefore, for simplicity of presentation, adjustments for openings, overturning, wall height, and torsion are ignored (though the torsion calculations are illustrated in Section C.4). Also, since the three upper stories are identical, the second story is assumed to be critical; for brevity, calculations for the third and fourth stories are not provided here.

In this example, the wall lengths are calculated from Figures C-3 and C-4 with somewhat more precision than in Section C.1.

Long x direction walls:

Story	Total Wall Length (ft)	Peak Strength, at 0.7% Drift	Seismic Weight Above
Second story	299 ft	322 k	327 k
First story	278 ft	299 k	438 k

Base-normalized upper-story strength (Section 4.7.2):

$$A_U = 322 \div 438 = 0.73$$

Weak story ratio (Section 4.7.3): $A_W = 299 \div 322 = 0.93$

Strength degradation ratio (Section 4.7.4): $C_D = 0.0$

Short y direction walls:

Story	Total Wall Length (ft)	Peak Strength, at 0.7% Drift	Seismic Weight Above
Second story	149 ft	160 k	327 k
First story	59 ft	63 k	438 k

Base-normalized upper-story strength (Section 4.7.2):

$$A_U = 160 \div 438 = 0.36$$

Weak story ratio (Section 4.7.3): $A_W = 63 \div 160 = 0.39$

Strength degradation ratio (Section 4.7.4): $C_D = 0.0$

Median Capacity and Spectral Acceleration Capacity (Sections 5.2 and 5.3). Because C_D is zero (due to sheathing with only plaster and wood lath), the median capacity may be calculated directly from Equation 5-2, with no interpolation between Equations 5-1 and 5-2 required.

$$S_{\mu 0,x} = (0.122 + 1.59A_{W,x})(1 - 0.5C_T)Q_s A_{U,x}^{0.60} \text{ for } C_D = 0.0$$

Similarly, the spectral capacity may be calculated directly from Equation 5-4, with no interpolation. The drift limit *POE* adjustment factor is taken from Table 5-1 based on the stated performance objective. For the 20 percent drift limit *POE* used in these examples, the value of $\alpha_{POE,0}$ is 0.60.

Long x direction:

$$S_\mu = (0.122 + 1.59 * 0.93) (1 - 0.5 * 0.0) 1.0 (0.73)^{0.60} = 1.33g$$

$$S_c = 0.60 * 1.33 = 0.80g$$

Short y direction:

$$S_\mu = (0.122 + 1.59 * 0.39) (1 - 0.5 * 0.0) 1.0 (0.36)^{0.60} = 0.40g$$

$$S_c = 0.60 * 0.41 = 0.24g$$

Evaluation (Section 5.4). The spectral acceleration capacity in each direction is less than the demand, $S_{MS} = 1.53g$, so the building fails the evaluation in both directions.

For this example, the building fails the evaluation even with the initial unconservative assumptions of zero torsion and no reduction for overturning. Had the building passed, the evaluation would have to be redone with torsion and overturning considered.

C.3 Retrofit (Chapter 6)

This example uses the evaluation results of Section C.2 to illustrate the *Guidelines*' retrofit procedure in concept. Again, the purpose is to explain the new capacity equations and the concept of optimized retrofit, not to provide a step-by-step calculation template. As in Section C.2, torsion is ignored (that is, C_T is taken as zero) both to simplify the presentation and because torsion

effects are expected to be mild in this particular building, especially after retrofit. (See Section C.4 for torsion calculations.)

For the initial pass through the retrofit equations, the strength degradation ratio, C_D , is still taken as zero, its value in the existing building. However, once ductile retrofit elements are added, the actual value of C_D will be greater than zero; this will become apparent as the retrofit design is confirmed and finalized. For discussion of the iterative retrofit design procedure, see *Guidelines* Section 6.2.1.

Thus, the values needed to apply the retrofit equations of *Guidelines* Sections 6.2.1 and 6.2.2 are:

$$Q_s = 1.0$$

$$C_T = 0.0 \text{ (assumed, to be confirmed; see Section C.4)}$$

$$C_D = 0.0 \text{ (to be revised upon design confirmation)}$$

$$A_U, V_U, \text{ and spectral demand } S_{MS} \text{ from previous examples.}$$

Drift limit *POE* adjustment factors for the stated performance objective with 20 percent *POE*, from Table 5-1: $\alpha_{POE,1} = 0.66$ and $\alpha_{POE,0} = 0.60$.

Estimated Minimum Required Strength (Section 6.2.1). The first-story strength required to meet the performance objective is given by Equation 6-1, but Equations 6-2 through 6-5 are applied first to generate the necessary coefficients.

Long x direction:

$$\begin{aligned} X_0 &= \alpha_{POE,1} A_U^{0.48} Q_s (1 - 0.5C_T) \\ &= 0.66 * 0.73^{0.48} * 1.0 (1 - 0.5 * 0.0) \\ &= 0.57 \end{aligned} \tag{6-2}$$

$$\begin{aligned} X_1 &= 2.24X_0 = 1.27 \text{ and} \\ X_2 &= 0.525X_0 = 0.30 \end{aligned} \tag{6-3}$$

$$\begin{aligned} Y_0 &= \alpha_{POE,0} A_U^{0.6} Q_s (1 - 0.5C_T) \\ &= 0.60 * 0.73^{0.60} * 1.0 (1 - 0.5 * 0.0) \\ &= 0.50 \end{aligned} \tag{6-4}$$

$$Y_1 = 1.59Y_0 = 0.79 \text{ and } Y_2 = 0.122Y_0 = 0.06 \tag{6-5}$$

$$V_{r,\min} = \frac{S_{MS} - X_2 C_D^3 - Y_2 (1 - C_D^3)}{X_1 C_D^3 + Y_1 (1 - C_D^3)} V_U \tag{6-1}$$

$$\begin{aligned}
V_{r,min} &= \frac{(1.53 - 0.30 \times 0.0^3 - 0.06(1 - 0.0^3))}{(1.27 \times 0.0^3 + 0.79(1 - 0.0^3))} V_U \\
&= \frac{1.47}{0.79} V_U \\
&= 1.86 V_U = 1.86 \times 322 \text{ k} \\
&= 599 \text{ k}
\end{aligned}$$

Short y direction:

$$\begin{aligned}
X_0 &= \alpha_{POE,1} A_U^{0.48} Q_s (1 - 0.5 C_T) \\
&= 0.66 \times 0.36^{0.48} \times 1.0 (1 - 0.5 \times 0.0) = 0.40
\end{aligned} \tag{6-2}$$

$$X_1 = 2.24 X_0 = 0.90 \text{ and } X_2 = 0.525 X_0 = 0.21 \tag{6-3}$$

$$\begin{aligned}
Y_0 &= \alpha_{POE,0} A_U^{0.6} Q_s (1 - 0.5 C_T) \\
&= 0.60 \times 0.36^{0.60} \times 1.0 (1 - 0.5 \times 0.0) = 0.33
\end{aligned} \tag{6-4}$$

$$Y_1 = 1.59 Y_0 = 0.52 \text{ and } Y_2 = 0.122 Y_0 = 0.04 \tag{6-5}$$

$$V_{r,min} = \frac{S_{MS} - X_2 C_D^3 - Y_2 (1 - C_D^3)}{X_1 C_D^3 + Y_1 (1 - C_D^3)} V_U \tag{6-1}$$

$$\begin{aligned}
V_{r,min} &= \frac{(1.53 - 0.21 \times 0.0^3 - 0.04 \times (1 - 0.0^3))}{(0.90 \times 0.0^3 + 0.52 (1 - 0.0^3))} V_U \\
&= \frac{1.49}{0.52} V_U = 2.87 V_U = 2.87 \times 162 \text{ k} = 465 \text{ k}
\end{aligned}$$

Estimated Maximum Acceptable Strength (Section 6.2.2). The first-story strength limit to avoid excessive upper-story drifts is given by Equation 6-6.

Long x direction:

$$\begin{aligned}
V_{r,max} &= (0.11 A_U + 1.22) \cdot V_U \tag{6-6} \\
V_{r,max} &= (0.11 * 0.73 + 1.22) * V_U = 1.30 * V_U \\
V_{r,max} &= 1.30 * 322 \text{ k} = 419 \text{ k}
\end{aligned}$$

Short y direction:

$$\begin{aligned}
V_{r,max} &= (0.11 A_U + 1.22) \cdot V_U \tag{6-6} \\
V_{r,max} &= (0.11 * 0.36 + 1.22) V_U = 1.26 V_U \\
&= 1.26 \times 162 \text{ k} = 204 \text{ k}
\end{aligned}$$

Estimated Range of Retrofitted Strength (Section 6.2.3). The minimum and maximum values calculated above are summarized in the following table. In both directions, the estimated minimum exceeds the estimated maximum, so it appears that no solution will satisfy the performance objective (unless the retrofit also substantially increases C_D , as shown below). In these cases, *Guidelines* Section 6.2.3 provides for an optimized retrofit strength within 10 percent of the estimated maximum (Equation 6-7), subject to a maximum acceptable drift limit *POE* (Section 6.4.2). Ignoring the maximum drift limit *POE* for now, the recommended strength range in each direction is as follows:

	Existing Strength	Minimum Required Strength	Maximum Acceptable Strength	Recommended Strength Range
Long x direction	299 k	599 k	419 k	377 – 461 k
Short y direction	63 k	465 k	204 k	184 – 224 k

Selection and Initial Sizing of the Retrofit Elements. The table above indicates roughly how much additional strength needs to be provided. As shown below, however, if the existing strength and the added strength occur at different drift levels, the total story strength will not be their simple sum. New sheathing may also replace existing sheathing, so the net strength increase should also consider the amount of existing strength removed.

Considerations of required strength and available locations for new elements, together with ample engineering experience and judgment, determine the retrofit element types and sizes to be considered with a trial design. Though outside the scope of this example, fire-safety requirements might also affect the types of appropriate sheathing and finishes. In addition to the primary retrofit elements, foundations, load path elements, and other details will need to be specified.

As an initial scheme, consider wood structural panels (WSP) comprising plywood nailed to existing studs along first-story wall lines, primarily those that stack with walls above. This will require the removal of existing lath and plaster.

Long *x* direction:

Referring to *Guidelines* Table 4-1, WSP sheathing with 8d nails at 2 inches is good for a peak strength of 2192 plf at a drift of 3.0%. Since the existing plaster contributes no strength at that drift, consider the WSP acting alone. Per the table above, if 377 k of strength are needed, then $377 \text{ k} / 2.192 \text{ klf} = 172 \text{ ft}$ of new WSP sheathing are needed.

Thus, as a trial design:

- Replace 96 linear feet of existing lath and plaster with 5/8-inch WSP (8d@2") on the inside face of existing perimeter stud walls (on lines 1 and 6), in four roughly equal segments of 24 feet each.
- Replace 76 linear feet of existing lath and plaster with 5/8-inch WSP (8d@2") on other interior first-story walls, located so that the overall first story resistance is symmetric and minimizes torsion.

While the retrofit is initially sized based on strength at 3.0% drift, it is possible that the story's peak strength will occur at a lower drift and will be based on a combination of the new WSP and the existing plaster. As the design is confirmed, it will be necessary to ensure that the peak strength does not exceed the recommended range.

Short y direction:

Again consider 5/8-inch WSP (8d@2"). The total length of wall needed to achieve strength in the range shown above would be $184 \text{ k} / 2.192 \text{ klf} = 84 \text{ ft}$. To locate this new sheathing on walls that align with walls above will require replacement of existing lath and plaster on both faces.

Thus, as a trial design:

- Replace 42 linear feet of existing lath and plaster with 5/8-inch WSP (8d@2"), each face, at existing wall locations, with the length on each line limited as needed to maintain symmetry and minimize torsion (see Section C.4).

This scheme may require some minor relocation or extension of interior first-story walls, which would likely also involve new or extended foundation elements. If the retrofit walls cannot fit in the space without interfering with the garage area drive aisle (see Figure C-3), an alternative design could use single-bent steel moment frames, or a combination of steel frames and wood structural panels. Guidelines for selecting, sizing, and detailing a steel frame system are given in Sections 6.5 and 6.5.4.

Confirmed Performance (Section 6.4). The measure of a retrofit design is not whether it hits the strength range estimated in *Guidelines* Chapter 6 but whether it satisfies the evaluation criteria from Chapter 5 and Section 6.4. Therefore, the retrofit design is re-characterized and re-evaluated. The key parameters are:

$$Q_s = 1.0 \text{ (unchanged)}$$

$C_T = 0.0$ (assumed, to be confirmed per Section 6.4.2; see Section C.4)

C_D no longer 0.0, to be recalculated based on retrofit load-drift curves.

A_U , V_U , and spectral demand S_{MS} from previous examples.

Note that the upper story strength and base-normalized strength do not change with a first story-only retrofit (unless the retrofit changes the seismic weight of the building significantly).

Drift limit POE adjustment factors for the stated performance objective with 20 percent POE , unchanged: $\alpha_{POE,1} = 0.66$ and $\alpha_{POE,0} = 0.60$.

In Section C.2, with only one wall type to evaluate, it was only necessary to check the peak strength at a single drift level. For the retrofit, which combines existing brittle elements with new relatively ductile elements, it is necessary to consider more of the load-drift curve in order to locate the peak story strength. In particular, the strength at 3.0% drift is needed to calculate the new value of C_D . Therefore, the example calculations that follow show wall strengths at three drift levels. (In the two calculation tables that follow, existing lath and plaster, denoted “E,” is replaced for certain lengths by new WSP sheathing, denoted “N,” and no additional sheathing or finishes that would add even more strength is installed over the new WSP.)

Long x direction:

Story and Wall Type	Total Wall Length (ft)	Strength at 0.7% Drift	Strength at 1.0% Drift	Strength at 3.0% Drift	Seismic Weight Above
Second story (E, 2-side), 1076 plf peak	299 ft	322 k	248 k	0 k	327 k
First story (E+N, 2-side), comprising:	278 ft	--	--	--	438 k
- First story (N, 1-side), 2192 plf peak	172 ft	267 k	295 k	377 k	--
- First story (E, 1-side), 269 plf peak*	172 ft	46.3 k	35.6 k	0 k	--
- First story (E, 2-side), 1076 plf peak	106 ft	114 k	87.8 k	0 k	--
First story, total load-drift curve	--	427 k	418 k	377 k	--

* Non-WSP materials combined with WSP materials in the same wall assembly are subject to a 50% strength factor per Section 4.5.1, so the strength shown is 269 plf = 0.50 x 538 plf.

Base-normalized upper-story strength (Section 4.7.2):

$$A_U = 322 \div 438 = 0.73$$

Weak story ratio (Section 4.7.3): $A_W = 427 \div 322 = 1.33$

Strength degradation ratio (Section 4.7.4): $C_D = 377 \div 427 = 0.88$

Comparing with the corresponding values from the existing structure in Section C.2:

- The peak story strength still occurs at 0.7% drift, but the retrofitted story now has strength even beyond 3.0% drift.
- The weak-story ratio has increased to about 1.3, due in part to the contributions of the remaining existing walls to the first story peak strength. The peak strength of 427 k is still within the recommended range determined above.
- The strength degradation ratio has increased substantially, from 0.0 to 0.88. Evaluation of the retrofit design using *Guidelines* Equations 5-1 through 5-5 will now involve interpolation.

Substituting into Equations 5-1 through 5-4:

$$S_{c,I} = 0.66 (0.525 + 2.24 \times 1.33) (1 - 0.5 \times 0) (1.0) (0.73)^{0.48} = 1.99g$$

$$S_{c,0} = 0.60 (0.122 + 1.59 \times 1.33) (1 - 0.5 \times 0) (1.0) (0.73)^{0.60} = 1.11g$$

Interpolating per Equation 5-5:

$$S_c = 0.88^3(1.99g) + (1-0.88^3) (1.11g) = 1.36g + 0.35g = 1.71g$$

The spectral acceleration capacity is now greater than the spectral acceleration demand of 1.53g, so this retrofit design appears to meet the performance objective in the long x direction. Keep in mind, however, that for purposes of this example, torsion has been neglected, as have the effects of openings within existing wall lines. The additional capacity above the demand might be enough to accommodate a small amount of torsion.

Short y direction:

Story and Wall Type	Total Wall Length (ft)	Strength at 0.7% Drift	Strength at 1.0% Drift	Strength at 3.0% Drift	Seismic Weight Above
Second story (E, 2-side), 1076 plf peak	149 ft	160 k	123 k	0 k	327 k
First story (E+N, 2-side), comprising:	59 ft	--	--	--	438 k
- First story (N, 2-side), 4384 plf peak	42 ft	130 k	144 k	184 k	--
- First story (E, 2-side), 1076 plf peak	17 ft	18.2 k	14.0 k	0 k	--
First story, total load-drift curve	--	148 k	158 k	184 k	--

Base-normalized upper-story strength (Section 4.7.2):

$$A_U = 160 \div 438 = 0.36$$

Weak-story ratio (Section 4.7.3): $A_W = 184 \div 160 = 1.15$

Strength degradation ratio (Section 4.7.4): $C_D = 184 \div 184 = 1.0$

Comparing with the corresponding values from the existing structure in Section C.2, we see how the added elements are dominating the retrofitted first story more in the short direction than in the long direction, because the existing short direction was so much weaker:

- The peak strength of the retrofitted first story now occurs where the strength of the retrofit elements is highest, at 3.0% drift.
- The first-story strength has increased only to 184 k, which is at the low end of the recommended range and just satisfies Equation 6-7. The existing elements make no usable contribution to the first-story strength.
- The strength degradation ratio has increased fully to 1.0.

With the new C_D equal to 1.0, the spectral capacity of the retrofit can be calculated without interpolation, directly from Equations 5-1 and 5-3:

$$S_{c,l} = 0.66 (0.525 + 2.24 \times 1.15) (1 - 0.5 \times 0) (1.0) (0.36)^{0.48} = 1.25g$$

At 1.25g, the spectral acceleration capacity in the short direction is greatly increased from the existing value of 0.24g but is still less than the spectral acceleration demand of 1.53g, so this retrofit does not meet the performance objective, though this was expected from the estimated retrofit range. The actual capacity might be slightly lower due to torsion, ignored here.

The retrofit elements were sized to hit the low end of that range, resulting in the minimum amount of new material and the least disruption of the existing walls and first-floor layout. Adding a greater length of new WSP sheathing, while staying within the practical range, would increase the spectral capacity, but it would also require more coordination to make the new elements fit within the existing space.

Since the retrofit does not meet the performance objective, two additional checks are required (per *Guidelines* Section 6.4.2). Briefly:

- The retrofit elements must be located so as to minimize torsion. The calculation of eccentricities and torsion is illustrated in Section C.4.
- The drift limit *POE* of the retrofitted structure must be less than the maximum acceptable drift limit *POE*, if one is specified for the project. With C_D equal 1.0, the actual drift limit *POE* is calculated quickly with Equation 5-7 as approximately 32 percent, not far off from the 20 percent

objective. Since no maximum acceptable value was set for this example, however, no conclusion as to acceptability is reached here.

C.4 Torsion Calculations (Chapters 3 and 4)

This example illustrates the *Guidelines*' procedures to account for torsion. In general, this example building is not expected to undergo significant torsion, even in its existing state. With substantial walls along three sides and partial walls along the open front, the building is likely to have some eccentricity, but not nearly as much as a building with two fully open sides. Nevertheless, the torsion calculations are an important feature of the *Guidelines* procedures, so they are illustrated here.

Center of Strength Location and Eccentricity (Sections 3.4.4 through 3.4.6 and 4.6.4 through 4.6.5). The following tables illustrate the bookkeeping used to calculate the center of strength (*COS*) at each story, from which eccentricities and torsion parameters are derived. The wall lengths and locations are from Figures C-3 and C-4. In the figures, dimension strings also show the cumulative distance from the origin (at the upper left of each figure).

The *Guidelines* provide two sets of equations for determining the *COS*, one in Chapter 3 for simplified evaluation, and one in Chapter 4 for full evaluation. There are two significant differences between them:

- The full evaluation considers the strength of each wall line at the drift at which the whole story reaches its peak strength. By contrast, the simplified evaluation considers each wall line at its own peak strength. For this example, where the existing building has only one wall type, the peak strength of each wall line and of the story as a whole all occur at the same drift level, so there will be no difference between the two *COS* calculations in this regard.
- The full evaluation considers the strength of each full wall line, discounted for the openings between full-height wall segments. The simplified evaluation considers only the full height segments (and thus underestimates the wall line strength). In these examples, the effects of openings have been ignored and only full height wall segments have been considered, so for this example there will be no difference between the two *COS* calculations in this regard.

As described in previous examples, the existing walls are all sheathed with lath and plaster on both sides. From *Guidelines* Table 3-2 or 4-1, the peak

unit strength of each wall (which occurs at a drift of 0.7%) is therefore 2 x 538 plf, or 1076 plf. This is the strength at which the *COS* is calculated. In the tables that follow, the wall lengths do not exactly match the approximations used in Sections C.2 and C.3.

First Story, Long (x) Direction walls, Existing Building					
Grid	y [ft]	L [ft]	v at 0.7% [plf]	V at 0.7% [k]	(V) x (y) [ft-k]
1:A	0.00	21.00	1076	22.6	0
1:D	0.00	36.00	1076	38.7	0
2:A	3.67	28.00	1076	30.1	111
2:D	3.67	36.00	1076	38.7	142
3:B	6.25	21.42	1076	23.0	144
4:A	20.08	50.00	1076	53.8	1080
5:C	23.75	21.42	1076	23.0	547
6:A	28.42	36.00	1076	38.7	1101
6:E	28.42	28.00	1076	30.1	856
Total		277.84		299.0	3982

First Story, Short (y) Direction Walls, Existing Building					
Grid	x [ft]	L [ft]	v at 0.7% [plf]	V at 0.7% [k]	(V) x (x) [ft-k]
A:2	0.00	3.25	1076	3.5	0
A:3.5	0.00	5.58	1076	6.0	0
A.3:4	7.42	3.58	1076	3.9	29
A.3:5	7.42	3.00	1076	3.2	24
B:2	28.00	3.00	1076	3.2	90
C:5	36.00	6.00	1076	6.5	232
D:2	50.00	3.00	1076	3.2	161
E:5	58.00	6.00	1076	6.5	374
F:2	86.00	25.17	1076	27.1	2329
Total		58.58		63.0	3240

Thus, the first story *COS* is calculated (by either Equation 3-4 or Equation 4-12) as:

$$COS_1 = (3240/63, 3982/299) = (51.4 \text{ ft}, 13.3 \text{ ft})$$

Upper Story, Long (x) Direction Walls, Existing Building					
Grid	y [ft]	L [ft]	v at 0.7% [plf]	V at 0.7% [k]	(V) x (y) [ft-k]
1:A	0.00	28.00	1076	30.1	0
1:E	0.00	28.00	1076	30.1	0
3:B	6.25	29.42	1076	31.7	198
3.5:A	14.00	12.00	1076	12.9	181
3.7:A.5	19.00	4.00	1076	4.3	82
3.4:A.6	10.50	11.42	1076	12.3	129
3.5:A.6	14.00	7.42	1076	8.0	112
3.6:A.6	17.30	7.42	1076	8.0	138
3.5:B	14.00	29.42	1076	31.7	443
3.4:E	10.50	11.42	1076	12.3	129
3.5:E	14.00	11.42	1076	12.3	172
3.6:B	17.30	3.00	1076	3.2	56
3.6:D	17.30	5.00	1076	5.4	93
3.6:E.2	17.30	7.42	1076	8.0	138
3.5:E.5	14.00	12.00	1076	12.9	181
6:A	23.75	28.00	1076	30.1	716
5:B	28.42	29.42	1076	31.7	900
6:E	28.42	28.00	1076	30.1	856
Total		292.78		315.0	4523

Upper Story, Short (y) Direction Walls, Existing Building					
Grid	x [ft]	L [ft]	v at 0.7% [plf]	V at 0.7% [k]	(V) x (x) [ft-k]
A:1	0.00	2.67	1076	2.9	0
A:3.5	0.00	5.17	1076	5.6	0
A:5.5	0.00	2.67	1076	2.9	0
A.5:1	12.00	10.42	1076	11.2	135
A.5:4	12.00	10.42	1076	11.2	135
A.6:3.5	16.00	3.33	1076	3.6	57
B:1	28.00	6.25	1076	6.7	188
B:3.5	28.00	4.42	1076	4.8	133
B:4	28.00	12.00	1076	12.9	362
C:3	37.00	4.42	1076	4.8	176
C:4	37.00	6.00	1076	6.5	239
D:3	48.00	4.42	1076	4.8	228
D:4	48.00	6.00	1076	6.5	310
E:1	58.00	13.50	1076	14.5	843

Note: continued on next page

Upper Story, Short (y) Direction Walls, Existing Building					
Grid	x [ft]	L [ft]	v at 0.7% [plf]	V at 0.7% [k]	(V) x (x) [ft-k]
E:4	58.00	12.00	1076	12.9	749
E.4:3.5	70.00	3.33	1076	3.6	251
E.4:4	70.00	9.00	1076	9.7	678
E.5:1	74.00	10.42	1076	11.2	830
E.5:4	74.00	10.42	1076	11.2	830
F:1	86.00	2.67	1076	2.9	247
F:3.5	86.00	5.17	1076	5.6	478
F:5.5	86.00	2.67	1076	2.9	247
Total		147.37		158.6	7114

The *COS* for all upper stories is thus:

$$COS_2 = (7114/159, 4523/315) = (44.7 \text{ ft}, 14.4 \text{ ft})$$

Comparing the first story and upper story centers of strength gives the eccentricities (per Equation 3-5 or Equations 4-13 and 4-14):

$$e_x = 51.4 - 44.7 = 6.7 \text{ ft. } e_y = 14.4 - 13.3 = 1.1 \text{ ft}$$

Simplified Torsion Coefficient (Section 3.4.7). For simplified evaluation, the torsion coefficient is approximated by Equation 3-6:

$$C_{Ts} = 4 (e_x + e_y) / (L_x + L_y) = 4 (6.7 + 1.1) / (86.5 + 30.0) = 0.27$$

Reviewing Section C.1 shows the effect this approximation has on the estimated spectral capacity. When torsion was ignored, *Guidelines* Equation 3-8 included a factor of 1.47. With the calculated coefficient, this factor becomes $(1.47 - 0.73 \cdot 0.27)$, or 1.27, a reduction of 13 percent. That is, for this building, the simplified capacity estimated with torsion considered is about 87 percent of the capacity estimated without torsion.

Note that the greatest portion of the reduction results from the *x*-direction eccentricity of 6.7 ft. *Guidelines* Section 6.4.2 accepts an unavoidable eccentricity that is less than 10 percent of the building dimension. In this case, 6.7 ft is less than 10 percent of the 86.5-ft long dimension, yet it still has an effect on the simplified capacity estimate.

Torsion Coefficient (Sections 4.6.6 through 4.6.8 and Section 4.7.5). For the full evaluation, the torsion coefficient is a function of the potential first-story torsional demand and the first-story torsional strength, considering the load-drift behavior of each wall line over a range of twist angles (Section 4.6.6). At each twist angle, the corresponding drift of each wall line is

determined, and the in-plane force resisted by that wall line is then determined from its load-drift curve (derived from *Guidelines* Table 4-1).

While the *Guidelines* prescribe a method of checking ten incremental rotations, the torsional strength can also be found by iteration with a spreadsheet. The torsional strength will generally occur when the major walls in one direction or the other reach their peak strength. For example, the following table shows the torsional strength where the short-direction end wall on line F, shown shaded, reaches its peak strength (1076 plf) at 0.7% drift. At this point, the torsion resisted by the walls is 2976 ft-k (of which 1294 ft-k is provided by the long-direction walls and 1682 ft-k is provided by the short-direction walls).

First Story, Long (x) Direction Walls, Existing Building							
Grid	y [ft]	L [ft]	d_y [ft]	drift [%]	v [plf]	V [k]	T = (V) x (d_y) [ft-k]
1:A	0.00	21.00	-13.3	0.27	474	10.0	133
1:D	0.00	36.00	-13.3	0.27	474	17.1	227
2:A	3.67	28.00	-9.6	0.20	344	9.6	93
2:D	3.67	36.00	-9.6	0.20	344	12.4	119
3:B	6.25	21.42	-7.1	0.14	252	5.4	38
4:A	20.08	50.00	6.8	0.14	241	12.0	81
5:C	23.75	21.42	10.4	0.21	371	8.0	83
6:A	28.42	36.00	15.1	0.31	538	19.4	292
6:E	28.42	28.00	15.1	0.31	538	15.1	227
						Total:	1294
First Story, Short (y) Direction Walls, Existing Building							
Grid	x [ft]	L [ft]	d_x [ft]	drift [%]	v [plf]	V [k]	T = (V) x (d_x) [ft-k]
A:2	0.00	3.25	-51.4	1.04	794	2.6	133
A:3.5	0.00	5.58	-51.4	1.04	794	4.4	228
A.3:4	7.42	3.58	-44.0	0.89	919	3.3	145
A.3:5	7.42	3.00	-44.0	0.89	919	2.8	121
B:2	28.00	3.00	-23.4	0.47	833	2.5	59
C:5	36.00	6.00	-15.4	0.31	549	3.3	51
D:2	50.00	3.00	-1.4	0.03	50	0.2	0
E:5	58.00	6.00	6.6	0.13	235	1.4	9
F:2	86.00	25.17	34.6	0.70	1076	27.1	937
						Total:	1682

However, this condition does not yield the maximum torsional strength, which occurs when the substantial long-direction walls on line 6 reach their peak, as shown in the following table (with the line 6 walls shown shaded). Note that at this point, the short-direction walls on line A have already failed and are no longer resisting any force. Still, the total torsional resistance is higher: 3195 ft-k (2745 ft-k from the long-direction walls and 450 ft-k from the short-direction walls).

Thus, the torsional strength, T , is 3195 ft-k.

First Story, Long (x) Direction Walls, Existing Building							
Grid	y [ft]	L [ft]	d_y [ft]	drift [%]	v [plf]	V [k]	$T = (V) \times (d_y)$ [ft-k]
1:A	0.00	21.00	-13.3	0.62	995	20.9	278
1:D	0.00	36.00	-13.3	0.62	995	35.8	477
2:A	3.67	28.00	-9.6	0.45	787	22.0	213
2:D	3.67	36.00	-9.6	0.45	787	28.3	273
3:B	6.25	21.42	-7.1	0.33	577	12.3	87
4:A	20.08	50.00	6.8	0.31	552	27.6	186
5:C	23.75	21.42	10.4	0.48	851	18.2	190
6:A	28.42	36.00	15.1	0.70	1076	38.7	585
6:E	28.42	28.00	15.1	0.70	1076	30.1	455
						Total:	2745
First Story, Short (y) Direction Walls, Existing Building							
Grid	x [ft]	L [ft]	d_x [ft]	drift [%]	v [plf]	V [k]	$T = (V) \times (d_x)$ [ft-k]
A:2	0.00	3.25	-51.4	2.38	0	0.0	0
A:3.5	0.00	5.58	-51.4	2.38	0	0.0	0
A.3:4	7.42	3.58	-44.0	2.04	0	0.0	0
A.3:5	7.42	3.00	-44.0	2.04	0	0.0	0
B:2	28.00	3.00	-23.4	1.08	755	2.3	53
C:5	36.00	6.00	-15.4	0.71	1064	6.4	98
D:2	50.00	3.00	-1.4	0.07	115	0.3	0
E:5	58.00	6.00	6.6	0.31	538	3.2	21
F:2	86.00	25.17	34.6	1.60	317	8.0	276
						Total:	450

The first story torsional demand is calculated by *Guidelines* Equation 4-20:

$$e_x V_{ly} + e_y V_{lx} = (6.7 \text{ ft})(63 \text{ k}) + (1.1 \text{ ft})(299 \text{ k}) = 422 + 329 = 751 \text{ ft-k}$$

Finally, the torsion coefficient is calculated from *Guidelines* Equation 4-26:

$$C_T = (751 \text{ ft-k}) / (3195 \text{ ft-k}) = 0.24.$$

Reviewing Section C.2 shows that a C_T value of 0.24 has a mild effect on the spectral capacity. When torsion is ignored, *Guidelines* Equations 5-1 and 5-2 each include a factor of 1.0 for potential torsion. With the calculated coefficient, this factor becomes $(1.0 - 0.50 \cdot 0.24)$, or 0.88. That is, for this building, the spectral acceleration capacity with torsion considered is 88 percent of the capacity estimated without torsion.

Locating Retrofit Elements (Section 6.3). Any ineligible condition must be made eligible for the application of the *Guidelines*' procedures to be valid (see *Guidelines* Section 2.6). As noted at the beginning of this appendix, the overall diaphragm aspect ratio exceeds the 2:1 limit unless the short existing walls at the ends of the light wells are adequate as qualifying walls. With the retrofit scope determined in Section C.3, this question becomes moot, assuming retrofit elements will be located so as to create eligible diaphragm segments between the retrofit wall lines. This is achieved by locating the short direction retrofit elements along lines B, C, D and/or E.

In addition, because the optimized retrofit in the short y direction will not achieve the stated performance objective (see the latter portion of Section C.3), the proposed retrofit elements must be located so as to minimize torsion. This example illustrates the requirement by assuming the confirmed retrofit solution from Section C.3 and redoing the *COS* calculation in the short direction.

From the example in Section C.3, the proposed short-direction retrofit replaces about 42 ft of existing plaster-sheathed wall (1076 plf peak strength at 0.7% drift) with 2-sided WSP (4384 plf peak strength at 3.0% drift), providing the estimated required strength of 182 k.

From the calculation above, the x component of the existing first story *COS* is 51.4 ft from the front of the building. The eccentricity (and the resulting torsion) will be minimized if the *COS* can be shifted toward the front of the building to match the second story *COS*, at $x = 44.7$ ft. Per *Guidelines* Section 6.3, an eccentricity less than 10 percent of the building dimension—in this case about 8.5 ft—is acceptable. The existing eccentricity of 6.7 ft is thus already acceptable if necessary, but the performance would be better if this value can be minimized by trial and error location of retrofit elements.

Following *Guidelines* Section 4.6.4, the *COS* is calculated with wall line strengths at the drift corresponding to the story's peak strength. As shown in

the confirmation calculation in Section C.3, the peak strength of the retrofit scheme is expected to occur at 3.0% drift, at which point any remaining plaster walls do not contribute any strength. Therefore, the retrofit *COS* calculation, per the tables below, considers only the new retrofit elements at 4384 plf. (For this example, adjustments for overturning and openings are again ignored for simplicity of presentation.)

The easiest retrofit layout would simply re-sheath the existing walls at their current lengths (see Figure C-3). The short-wall segments on line A.3 are ignored, as they are not perimeter walls and might not have footings adequate for a WSP wall. Otherwise, if all the wall segments toward the front of the building are fully sheathed, and the balance of the required wall length is added to the wall on line F, the *COS* will be at $x = 9531/187.8 = 50.8$ ft, as shown by the following calculation table:

First Story, Short (y) Direction Walls, Retrofitted Building					
Grid	x [ft]	L [ft]	v at 3.0% [plf]	V at 3.0% [k]	(V) x (x) [ft-k]
A:2	0.00	3.25	4384.0	14.3	0
A:3.5	0.00	5.58	4384.0	24.5	0
B:2	28.00	3.00	4384.0	13.2	368
C:5	36.00	6.00	4384.0	26.3	947
D:2	50.00	3.00	4384.0	13.2	658
E:5	58.00	6.00	4384.0	26.3	1526
F:2	86.00	16.00	4384.0	70.1	6032
Total		42.83		187.8	9531

This *COS* location reduces the eccentricity slightly and is acceptable by the *Guidelines*, but it does not minimize torsion. One alternative approach might lengthen the wall segment on line B and shorten the segment on line F to maintain the same overall length of new wall, but this might interfere with the use of the parking area.

Another alternative might use a stronger WSP type at line A, and shorten the line F wall to maintain the same overall required strength of 182 k. The following table shows the results of this approach, using a peak strength of 5024 plf along line A (Per Table 4-1, 2-sided WSP with 10d nails at 2 inches). This puts the *COS* at $x = 8777 / 184.6 = 47.5$ ft and reduces the eccentricity relative to the second story to $e_x = 47.5 - 44.7 = 2.8$ ft—still not zero, but significantly less than the existing condition.

First Story, Short (y) Direction Walls, Retrofitted Building (Alternative)					
Grid	x [ft]	L [ft]	v at 3.0% [plf]	V at 3.0% [k]	(V) x (x) [ft-k]
A:2	0.00	3.25	5024.0	16.3	0
A:3.5	0.00	5.58	5024.0	28.0	0
A.3:4	7.42	0.00	0.0	0.0	0
A.3:5	7.42	0.00	0.0	0.0	0
B:2	28.00	3.00	4384.0	13.2	368
C:5	36.00	6.00	4384.0	26.3	947
D:2	50.00	3.00	4384.0	13.2	658
E:5	58.00	6.00	4384.0	26.3	1526
F:2	86.00	14.00	4384.0	61.4	5278
Total		40.83		184.6	8777

Characterization of Existing Materials

D.1 Introduction

Buildings to be evaluated under these *Guidelines* have walls that are braced with a wide variety of sheathing and finish materials. The *Guidelines*' methodology incorporates load-drift curves for each of the commonly anticipated materials for which information is currently available. The purpose of this appendix is to provide background on the provisions of Sections 4.3 through 4.6 of the *Guidelines*, which characterize existing material and building load-drift behavior.

Sections D.2 through D.4 address information from which load-drift curves were derived. Section D.2 summarizes the available testing, organized by research project. Section D.3 illustrates load-drift backbone curves derived from the data in Section D.2 and discusses data included and adjustments made. Section D.4 discusses recommendations made for material property modeling in this *Guidelines* document.

Sections D.5 through D.8 address adjustment factors used in Section 4.5 to modify load-drift behavior. Section D.5 summarizes available data for characterizing combinations of bracing materials. Section D.6 addresses background for the adjustment factor for openings in the wall line. Section D.7 provides background for the adjustment factor for overturning. Section D.8 provides background for the drift adjustment for first-story wall-line height.

Section D.9 summarizes available research information relating observed damage to drift ratios. Finally, Section D.10 provides recommendations for research needed to allow future refinement of upper-story characterization.

D.2 Research Addressing Wall Bracing Materials

This section summarizes the available testing of wall bracing materials.

Forest Products Laboratory (1956)

The Rigidity and Strength of Frame Walls, Information Reviewed and Reaffirmed Report, No. 896 by G. W. Trayer, U. S. Department of

Agriculture (USDA) Forest Products Laboratory, March 1956. This test report describes testing that was originally conducted circa 1930. The purpose of the testing was to assess the strength and stiffness of wall bracing materials for light-frame construction, including horizontal sheathing, diagonal sheathing, and plaster on wood lath. Walls tested included 9'-0" high by 14'-0" long and 7'-4" high by 12'-1 $\frac{5}{8}$ " long assemblies. Both solid walls and walls with door and window openings were included. Most were tested using single-direction monotonic loading, while several others were loaded with a large number of vibration cycles. The test set-up included stiff overturning restraint of the panels, making the results comparable to the American Society for Testing and Materials (ASTM) E72 test methods.

Schmid (1984)

Shear Test of Existing Wood Lath and Plaster Walls Relative to Division 88, by Ben Schmid, 1984. In 1984, Ben Schmid tested two interior plaster and wood lath walls in an unreinforced masonry building in the City of Los Angeles. The walls started out 10-feet high by 11-to-14-feet long, and were cut down to 8 feet by 8 feet in order to allow attachment of the testing jacks. Both faces of the test walls had plaster and wood lath finishes. The bottom edges of the panel remained per original construction. The plaster and wood lath was cut vertically and left free to slide at the vertical edges. At the top edge, blocking was installed to restrain upward movement of the plaster and wood lath. The dead load of the floor above was used to resist overturning; however, during peak loads, uplift displacements of almost an inch were recorded. Testing was force-controlled and involved loading in one direction, release of the load, and loading in the opposite direction. The Test 1 panel withstood four excursions and failed on the fifth. The Test 2 panel withstood six excursions and failed on the seventh. Load histories, load-deflection plots and low-resolution photos of the testing are available.

Forest Products Laboratory (1940)

New England Eastern White Pine as a House Framing Material by E. C. O. Erickson, U. S. Dept. of Agriculture (USDA) Forest Products Laboratory, September 1940. This test report describes testing of second growth eastern white pine timber framing in order to evaluate differences in strength and rigidity from virgin growth. Based on currently tabulated specific gravities, the eastern white pine stiffness would be anticipated to be slightly less than coastal redwood. Walls tested were 7'-4" high by 12'-1 $\frac{5}{8}$ " long assemblies, fully sheathed without openings. Six sheathing configurations were used, including horizontal and diagonal lumber sheathing alone and in combination with let-in braces. Testing used single-direction monotonic loading. The test

set-up included stiff overturning restraint of the panels, making the results comparable to ASTM E72 test methods.

Forest Products Laboratory (1958)

Adequacy of Light Frame-Wall Construction Report, No. 2137 by R. F. Luxford, and W. E. Bosner, USDA Forest Products Laboratory, November 1958. The purpose of the testing was to assess methods to reduce costs through reduction of labor or materials. Control tests used horizontal sheathing of southern yellow pine. These results were compared to horizontal southern yellow pine sheathing with let-in braces and ¼ -inch Douglas-fir plywood sheathing with and without let-in braces. Walls tested were 8'-0" high by 12'-0" long, fully sheathed. Testing used single-direction monotonic loading. The test set-up included stiff overturning restraint of the panels, making the results comparable to ASTM E72 test methods.

Forest Products Laboratory (1951)

Results of Racking Tests of a Few Types of House-Wall Construction, by E. W. Kuenzi, USDA Forest Products Laboratory, in cooperation with Housing and Home Finance Agency, filed 16 October 1951. This report describes testing of various wall bracing materials, including horizontal and diagonal sheathing alone and in combination with let-in bracing, as well as a type of cement panel. Walls tested were 8'-0" high by 8'-0" long, fully sheathed. Walls were tested using single-direction monotonic. The test set-up included stiff overturning restraint of the panels, making the results comparable to ASTM E72 test methods. The available copy of the report is of poor print quality and nearly impossible to read. Information has been included based on the higher quality tables and figures.

City of Los Angeles (2001)

Report of a Testing Program of Light-Framed Walls with Wood-Sheathed Shear Panels by Structural Engineers Association of Southern California, City of Los Angeles – University of California at Irvine (COLA-UCI) Light Frame Test Committee, Subcommittee of Research Committee and Department of Civil and Environmental Engineering, University of California, Irvine, December 2001. This test report describes testing of 36 groups of shear walls sheathed with plywood, oriented strand board, stucco and gypsum wallboard, and includes both wood and cold-formed steel framing and a variety of sheathing fasteners. The testing was conducted on 8-ft-by-8-ft shear walls. Overturning restraint was provided by 4 × 4 end posts and specially designed heavy-duty tie-down devices, designed to minimize uplift deflection; these devices were purposely chosen to be substantially

stiffer than devices commonly used in construction. The test used the displacement controlled Technical Coordinating Committee for Masonry Research (TCCMAR) Sequential Phased Displacement (SPD) protocol, as published by the Structural Engineers Association of Southern California (SEAOSC) in 1997.

Pardoen et al. (2003)

Testing and Analysis of One-Story and Two-Story Shear Walls Under Cyclic Loading (California Universities for Research in Earthquake Engineering [CUREE] W-25 Report), by G. Pardoen, A. Waltman, R. Kazanjy, E. Freund, and C. Hamilton, 2003. This test report describes testing of 25 groups of one-story shear walls and two two-story shear walls, sheathed with oriented strand board (OSB), stucco, gypsum wallboard, and combinations thereof. Objectives included correlation between component tests and shake table tests and investigation of walls with combinations of sheathing materials. The one-story walls were 8-feet tall and 16-feet long. Configurations included fully sheathed, one pedestrian door opening, and one garage door opening. The walls matched the first-story walls of a single-family dwelling that was tested on the University of California (UC) San Diego shake table (CUREE W-2 Report). Commercially available tie-downs were used for overturning restraint. The sheathing materials were free to slip relative to framing on all four sides of the shear walls. One portion of the loading used the CUREE protocol. Another portion used displacement time histories recorded during the UC San Diego shake table testing.

McMullin and Merrick (2002)

Seismic Performance of Gypsum Walls: Experimental Test Program (CUREE W-15 Report), by K. McMullin and D. Merrick, 2002. This test report describes a series of 17 tests of gypsum wallboard sheathed walls. The overall wall was 8-ft high by 16-ft long. Test walls had either one door opening or one door and one window. Fastening used both nails at a spacing of eight inches on center or screws at a spacing of sixteen inches on center. These were chosen to replicate partition-wall construction that would not have been identified as structural shear walls. At the top, bottom, and ends of the walls, special attention was paid to develop detailing that would be representative of interior wall construction. At the wall ends and top, wood blocking was provided restricting the sheathing from sliding horizontally relative to the framing. At the wall base a 1/4-inch gap was provided beyond which a block stopped further slippage. This detailing is a significant departure from prior testing. The test setup used heavy tie-down rods to restrain wall ends against uplift, reflecting restraint that would be provided

by perpendicular walls. Testing used a combination of monotonic and CUREE protocols. Significant data was collected correlating drift levels to damage descriptions. See Tables 9 and 10 of the CUREE report for more detail.

American Plywood Association (1993)

Appendix A of American Plywood Association (APA) Report 154, *Wood Structural Panel Shear Walls*, 1993, provides ultimate loads for 5/16-inch and 3/8-inch plywood panel siding fastened with 6d casing nails spaced at six inches on center. Details of testing are not provided; however, based on Appendix E discussion, it is likely that these values were determined using ASTM E72 test methods.

Gatto and Uang (2002)

Cyclic Response of Woodframe Shearwalls: Loading Protocol and Rate of Load Effects (CUREE W-13 Report) by K. Gatto and C.-M. Uang, 2002.

This test report describes testing of plywood and stucco sheathed walls, both with and without gypsum wallboard and stucco finish materials. The primary focus of the testing was to determine the effect of various loading protocols, including the Sequential Phased Displacement (SPD), CUREE, and CUREE near-fault protocols and both quasi-static and dynamic loading rates. The tests were conducted on 8-ft-by-8-ft walls. Sheathing and finish materials were free to slip relative to the framing at all edges. Commercially available tie-down devices were used for overturning restraint. Several tests are incorporated into the recommendations in Section D.2 of the CUREE W-13 Report. In addition, recommendations from this report for conversions of test results between the CUREE and SPD protocols were used.

Schmid (2001)

In 2001, Ben Schmid tested shear walls with gypsum lath and plaster. The walls were part of a comparison to gypsum wallboard shear walls. The walls were 8' high by 10'-8" long, and the SEAOSC Sequential Phased Displacement (SPD) protocol was used in the testing. Test 3 had special detailing to provide continuity at all boundaries. Test 7 had special continuity detailing at the wall top only.

D.3 Load-Deflection Backbone

For each material for which information was available, mean backbone curves and beta values were derived from what was considered applicable data. This section summarizes the data that were determined to be applicable and the derived results. Beta is calculated using the formula: $\ln(1 + (\text{std}$

$\text{dev/mean})^2)^{0.5}$. The amount of data available did not justify refined determination of beta values for the capacity at various deflections. For this reason the following recommendations include betas of 0.15, 0.30 and 0.45 based on the calculated beta included in the tables, adjusted using engineering judgment based on the number of available tests.

In addition it is important to note that new load-drift curves are permitted to be developed for materials not described. These should use a cyclic load protocol (preferably the CUREE protocol, as the SPD protocol would require use of correction factors). The positive and negative quadrant values should be averaged and preferably no less than two tests would be included. Attention to realistic boundary conditions is of great importance in order to capture realistic load-drift behavior.

D.3.1 Plaster on Wood Lath

Table D-1 and Figure D-1 illustrate information available for quantification of load-drift behavior for plaster on wood lath. As can be seen, very limited information is available. The two sources included are the 1956 Forest Products Laboratory (FPL) monotonic testing with heavy overturning restraint and the cyclic testing with limited overturning restraint conducted

Table D-1 Load-Drift Data for Plaster on Wood Lath

Sheathing Shear Capacities (plf)										
Data Source / Type	Drift Ratio (%)									
	0	0.5	0.7	1	1.5	2	2.5	3	4	5
Forest Products Lab. (FPL) (1956) Test 11 (a)	0	720	814							
Schmid (1984) Test 1 (b)	0	300	350	359	391					
Schmid (1984) Test 2 (b)	0	300	450	469						
Average	0	440	538	414	391					
Standard deviation	0	242	244	78						
Covariance (COV)	0	55%	45%	19%						
Average + 1 standard deviation	0	682	782	492						
Average - 1 standard deviation	0	198	294	337						
Recommended upper bound	0	720	810							
Recommended lower bound	0	300	350	360	390					
ASCE/SEI 41, <i>Seismic Rehabilitation of Existing Buildings</i> (default properties)	Drift Ratio (%)									
	0	0.3	1.4	1.4	1.5					
	0	267	400	80	80					
(a) Monotonic testing. No description of post-peak behavior provided.										
(b) In-situ testing of existing walls. Limited load cycling.										

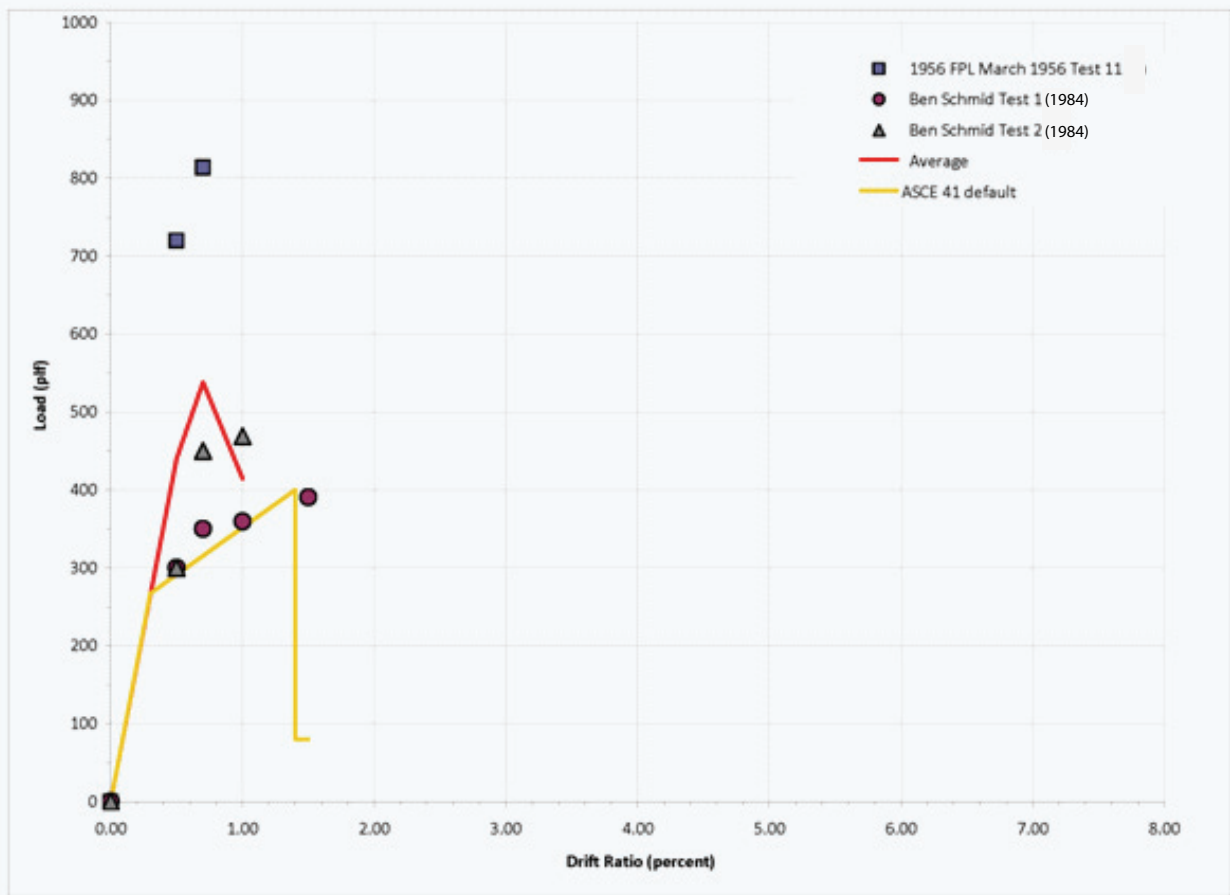

Figure D-1 Load-drift data for plaster on wood lath. FPL = Forest Products Laboratory. Additional information on testing procedures for each data source is provided in Table D-1.

by Schmid in 1984. The results of these two tests vary considerably. Because neither test could be deemed significantly more representative, it is recommended that the average of these tests be used to estimate load deflection behavior. ASCE/SEI 41 *Seismic Rehabilitation of Existing Buildings* (ASCE, 2006b) default properties are shown for comparison; peak capacities are in reasonable agreement, given the variability. A beta of 0.45 is recommended based on the combinations of low number of tests and high variability.

D.3.2 Horizontal Lumber Sheathing

Table D-2 and Figure D-2 illustrate information available for quantification of load-drift behavior for horizontal wood sheathing. The various reports available from the Forest Products Laboratory (FPL) provide several tests for consideration. From the FPL reports, tests that were used included horizontal sheathing only, and not let-in braces. This is based on the authors' observation of let-in bracing not being prevalent in San Francisco area

buildings with horizontal sheathing through the 1950s. All tests are understood to have been single-direction monotonic loading with heavy overturning restraint. All tests were considered equally applicable, and the average of the tests was recommended for use in estimating load-deflection behavior. ASCE/SEI 41 default properties are shown for comparison; of note is that all of the tests show considerably more displacement capacity than currently considered by ASCE/SEI 41. American Forest and Paper Association, *Special Design Provisions for Wind and Seismic* (AF&PA SDPWS) load and deflection at nominal capacity are also included for

Table D-2 Load-Drift Data for Horizontal Wood Sheathing

Sheathing Shear Capacities (plf)										
Data Source / Type	Drift Ratio (%)									
	0	0.5	0.7	1	1.5	2	2.5	3	4	5
Forest Products Laboratory (FPL) (1956) Test 1-4 average (a)	0	96	114	131	147	162	170	186		
FPL (1940) Test 1 (b)	0	77	81	88	99	110	121	133		
FPL (1940) Test 2 (b)	0	100	107	117	134	151	168	185		
FPL (1958) Control (c)	0	100	106	114	128	142	156	170	198	225
FPL (1951) Control (d)	0	50	70	100	150	160	170	180	200	220
Average	0	85	96	110	132	145	157	171		
Standard deviation	0	22	19	17	20	21	21	22		
Covariance (COV)	0.00	0.25	0.20	0.15	0.15	0.15	0.13	0.13		
Average + 1 Standard deviation	0.00	106.16	114.61	126.51	151.95	166.12	177.95	192.86		
Average - Standard deviation	0.00	63.04	76.59	93.49	111.25	123.88	136.05	148.74		
Beta		0.25	0.20	0.15	0.15	0.14	0.13	0.13		
Recommended Beta		0.15	0.15	0.15	0.15	0.15	0.15	0.15		
ASCE/SEI 41, <i>Seismic Rehabilitation of Existing Buildings</i> (default properties)	Drift Ratio (%)									
	0	0.24	1.2	1.2	1.4					
	0	53	80	24	24					
American Forest and Paper Association, <i>Special Design Provisions for Wind and Seismic</i>	Drift Ratio (%)									
	0	0.6								
	0	100								
(a) Monotonic testing. No description of post-peak behavior provided.										
(b) Monotonic testing. Load at 1.5 inch and peak known; balance is estimated.										
(c) Monotonic testing. Eastern white pine. Load at 0.5 inch and peak load known; balance is estimated.										
(d) Monotonic testing. Load at 1.5 inch and peak known; balance is estimated.										

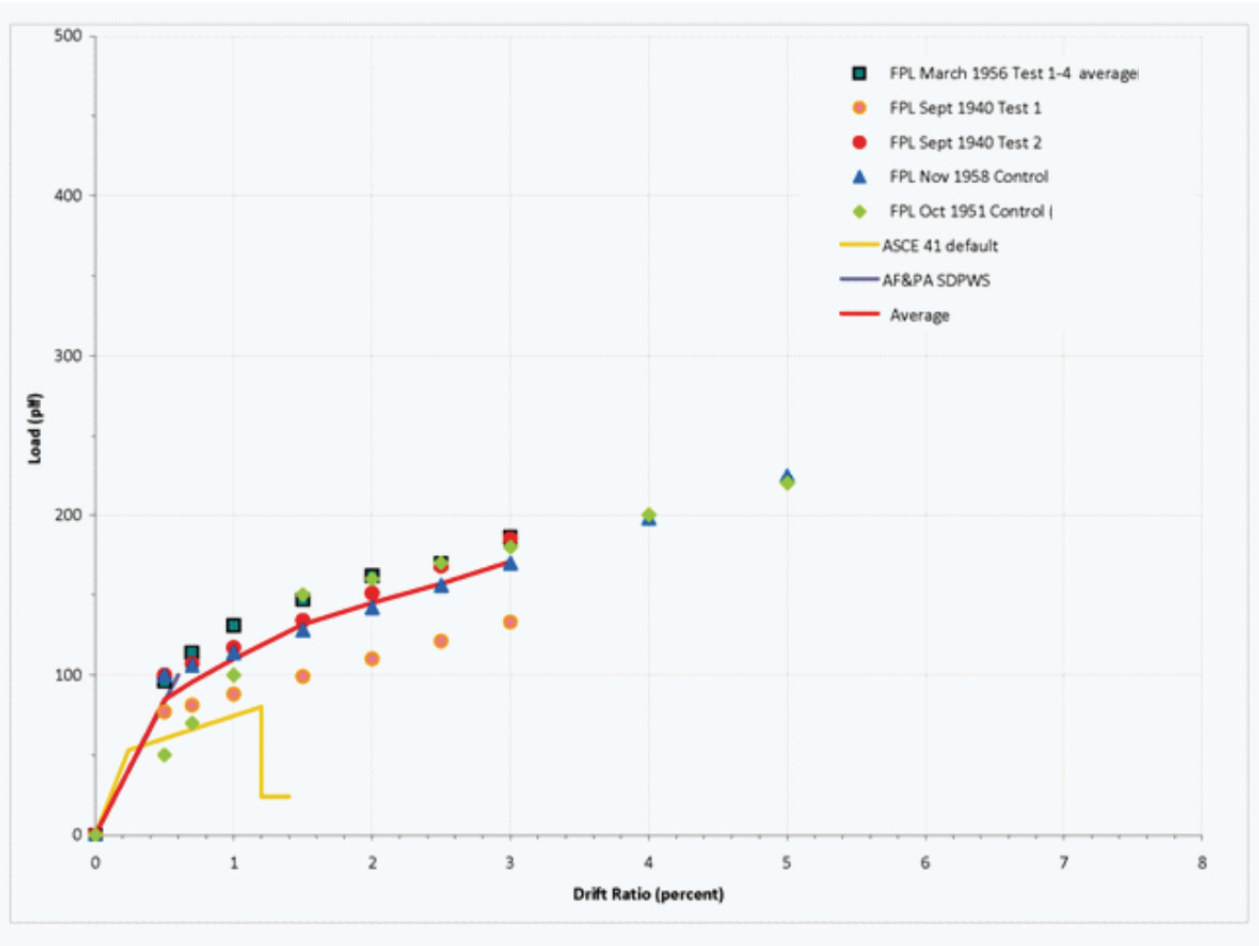

Figure D-2 Load-drift data for horizontal wood sheathing. FPL = Forest Products Laboratory. AF&PA SDPWS = American Forest and Paper Association, *Special Design Provisions for Wind and Seismic*. Additional information on testing procedures for each data source is provided in Table D-2.

comparison; the deflection only includes the shear component and not overturning deflection. Like ASCE/SEI 41, SDPWS appears to noticeably underestimate displacement capacity.

D.3.3 Diagonal Lumber Sheathing

Table D-3 and Figure D-3 illustrate information available for quantification of load-drift behavior for diagonal wood sheathing. Again, the various reports available from the Forest Products Laboratory (FPL) provide several tests for consideration. From the FPL reports, tests that were used included diagonal sheathing only, and not let-in braces. This is based on the authors' observation of let-in bracing not being prevalent in San Francisco area buildings with diagonal sheathing through the 1950s. All tests are understood to have been single-direction monotonic loading with heavy overturning restraint. This test group shows more variability than the horizontal sheathing;

however, all tests were considered equally applicable, and the average of the tests was recommended for use in estimating load deflection behavior. ASCE/SEI 41 default properties are shown for comparison; peak capacities are in reasonable agreement with the average of the available tests. American Forest and Paper Association, *Special Design Provisions for Wind and Seismic* (AF&PA SDPWS) load and deflection at nominal capacity are also included for comparison; the deflection only includes the shear component and not overturning deflection. The SDPWS nominal capacity appears somewhat conservative. A beta of 0.30 is recommended based on the combinations of moderate number of tests and variability.

Table D-3 Load-Drift Data for Diagonal Lumber Sheathing

Sheathing Shear Capacities (plf)										
Data Source / Type	Drift Ratio (%)									
	0	0.5	0.7	1	1.5	2	2.5	3	4	5
Forest Products Laboratory (FPL) (1956) Test 5 (a)	0	418	491	565	658					
FPL (1956) Test 31 (a)	0	252	297	342	397					
FPL (1956) Test 9A (b)	0	709	834	959	1116					
FPL (1940) Test 3 (c)	0	338	452	623	908					
FPL (1940) Test 5 (c)	0	433	599	848	1263					
FPL (1940) Test 7 (c)	0	426	567	780	1133					
Average	0	429	540	686	913					
Standard deviation	0	154	179	222	330					
Covariance (COV)	0	36%	33%	32%	36%					
Average + 1 standard deviation	0	583	719	908	1242					
Average - 1 standard deviation	0	276	361	464	583					
Beta		0.35	0.32	0.32	0.35					
Recommended Beta		0.30	0.30	0.30	0.30					
ASCE/SEI 41, <i>Seismic Rehabilitation of Existing Buildings</i> (default properties)	Drift Ratio (%)									
	0	0.5	1.6	1.6	2					
	0	467	700	140	140					
American Forest and Paper Association, <i>Special Design Provisions for Wind and Seismic</i>	Drift Ratio (%)									
	0	0.9								
	0	600								
(a) Monotonic testing; diagonals in tension. No description of load-deflection behavior beyond 1.5 inches was provided.										
(b) Monotonic testing; diagonals in compression. No description of load-deflection behavior beyond 1.5 inches was provided.										
(c) Monotonic testing; diagonals in tension. Capacity at 0.5 inch and peak given, balance estimated.										

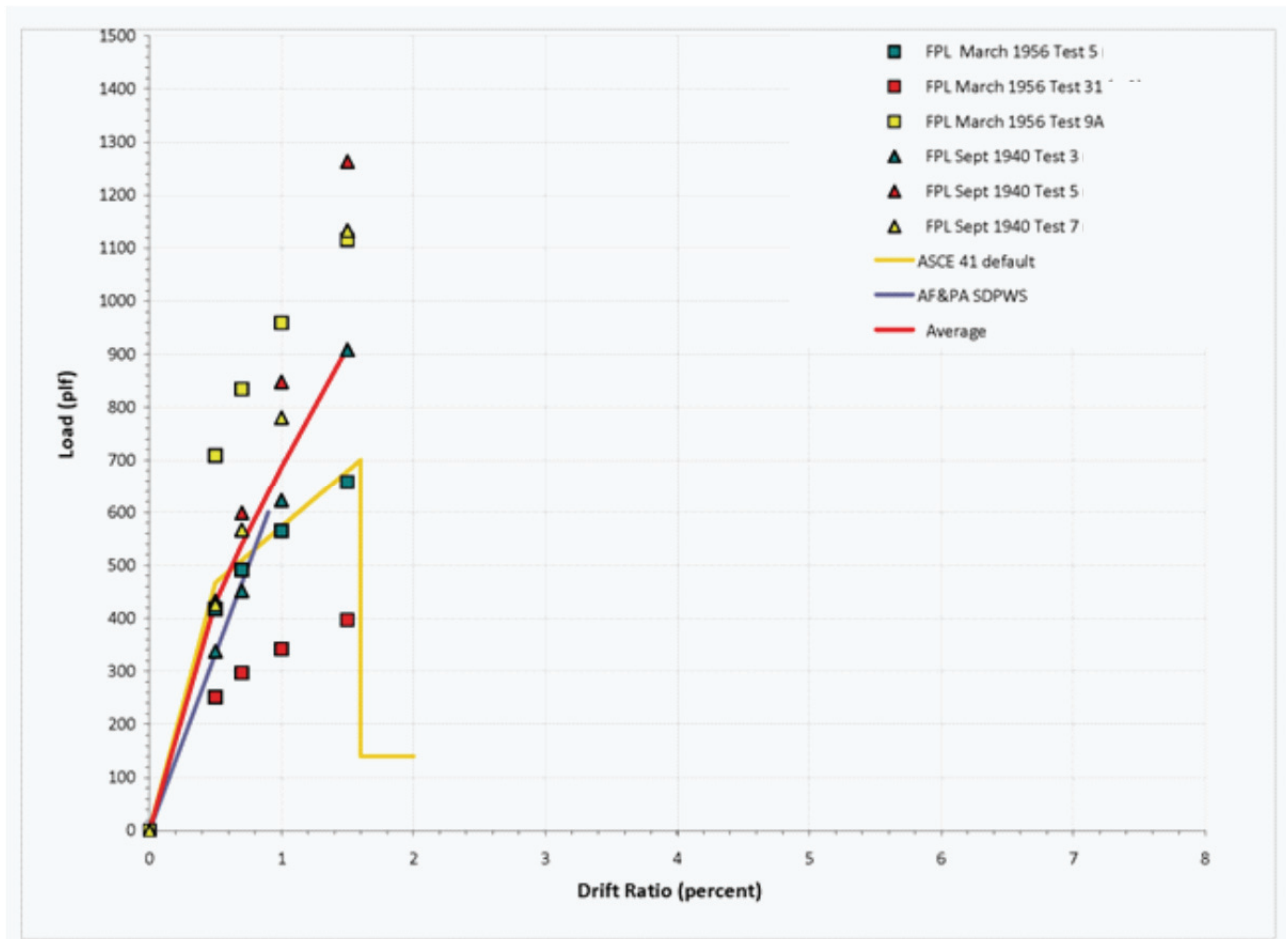

Figure D-3 Load-drift data for diagonal lumber sheathing. FPL = Forest Products Laboratory. AF&PA SDPWS = American Forest and Paper Association, *Special Design Provisions for Wind and Seismic*. Additional information on testing procedures for each data source is provided in Table D-3.

D.3.4 Stucco

Table D-4 and Figure D-4 illustrate information available for quantification of load-drift behavior for stucco (portland cement plaster). Available data includes four City of Los Angeles (CoLA) tests using SPD protocol and heavy tie-down restraint, and two Pardoen et al. (2003) tests with CUREE protocol and free boundaries at all edges. Also included due to their similarity are two Ben Schmid (2001) tests of plaster and gypsum lath. The Figure D-4 plot illustrates that the capacity and drift of the Pardoen et al. tests are significantly higher than other tests. The Pardoen et al. tests are not considered representative because of the boundary conditions with the stucco free to slip relative to framing; this resulted in a test of the reasonably ductile staples fastening the stucco rather than the more brittle stucco material. Similarly Schmid (2001) Test 3 shows peak capacity higher than the other tests. Both the Pardoen et al. (2003) tests and the Schmid (2001) Test 3 were removed from the group averaged in order to determine estimated load-

deflection behavior. The red line on the chart (Figure D-4) shows the average of the remaining group. Additional testing with appropriate boundary conditions is recommended. ASCE/SEI 41 default properties are shown for comparison and are reasonably comparable. A beta of 0.45 is recommended based on the combinations of low number of tests and high variability.

Table D-4 Load-Drift Data for Stucco

Data Source / Type	Sheathing Shear Capacities (plf)									
	Drift Ratio (%)									
	0	0.5	0.7	1	1.5	2	2.5	3	4	5
City of Los Angeles (CoLA) (2001) Test 20A (a)	0	344	332	219						
CoLA (2001) Test 20B (a)	0	379	379	278						
CoLA (2001) Test 21A (b)	0	325	325	262						
CoLA (2001) Test 21B (b)	0	325	312	289						
Schmid (2001) Panel 7B (c)	0	292	250							
Schmid (2001) Panel 3 (d)	0	512	443	304						
Pardoen et al. (2003) Test 16A (e)	0	375	582	621	655	695	745	745	745	745
Pardoen et al. (2003) Test 17A (f)	0	545	545	560	600	640	600	560	492	
Average	0	333	320	262						
Standard deviation	0	32	46	31						
Covariance (COV)	0	10%	15%	12%						
Average + 1 standard deviation	0	365	366	293						
Average - 1 standard deviation	0	301	273	231						
		0.10	0.14	0.12						
Recommended Beta		0.45	0.45	0.45						
ASCE/SEI 41, <i>Seismic Rehabilitation of Existing Buildings</i> (default properties)	Drift Ratio (%)									
	0	0.13	0.47	0.47	0.52					
	0	233	350	70	70					
(a) Cyclic testing, Sequential Phased Displacement (SPD) protocol. No confinement at boundaries. Furring nails at 6".										
(b) Cyclic testing, SPD protocol. No confinement at boundaries. Staples at 6".										
(c) Cyclic testing, SPD protocol. Confined at wall top only.										
(d) Cyclic testing, SPD protocol. Confined at all boundaries.										
(e) Cyclic testing, CUREE protocol. No confinement at boundaries. Wall with garage door.										
(f) Cyclic testing, CUREE protocol. No confinement at boundaries. Wall with pedestrian door.										

Gray cells not included in average, beta

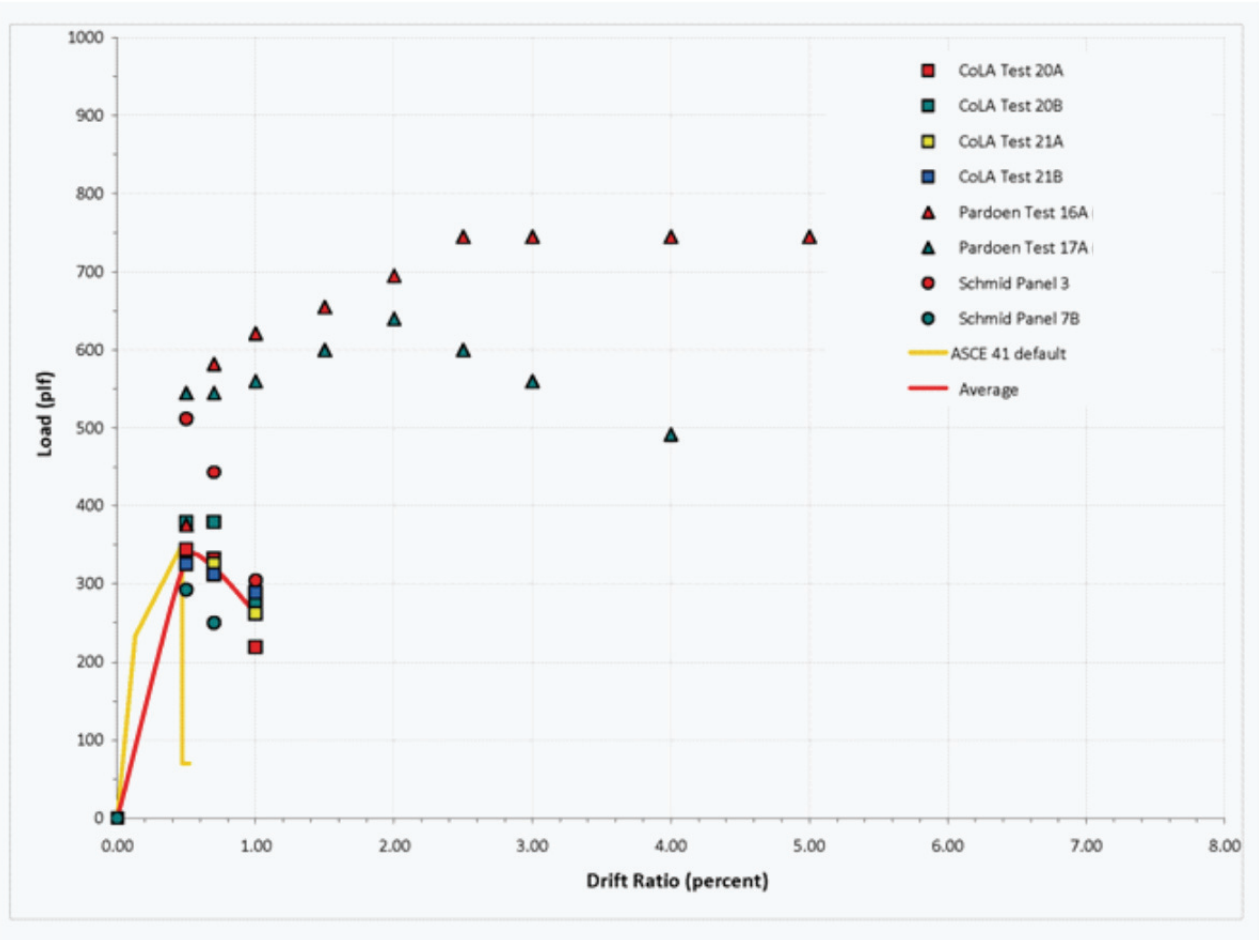

Figure D-4 Load-drift data for stucco. CoLA = City of Los Angeles. Additional information on testing procedures for each data source is provided in Table D-4.

D.3.5 Gypsum Wallboard

Table D-5 and Figure D-5 illustrate information available for quantification of load-drift behavior for gypsum wallboard. Included are four tests by McMullin and Merrick, two tests by Pardoen et al., two City of Los Angeles (CoLA) tests and one Schmid (2001) test. Overall the trend of load-deflection behavior is very similar among the tests, but the variation in capacity is large. Because of the construction of realistic boundary conditions in the McMullin and Merrick tests, these are felt to be more representative of expected properties than the other tests. For this reason the recommended estimate of average load-deflection behavior used the four McMullin and Merrick tests only. ASCE/SEI 41 default properties are shown for comparison; the ASCE/SEI 41 properties are significantly outside of the entire range of tests. American Forest and Paper Association, *Special Design Provisions for Wind and Seismic* (AF&PA SDPWS) are also significantly outside of the test data. A beta of 0.30 is recommended based on the combinations of moderate number of tests and higher variability.

Table D-5 Load-Drift Data for Gypsum Wallboard

Sheathing Shear Capacities (plf)										
Data Source / Type	Drift Ratio (%)									
	0	0.5	0.7	1	1.5	2	2.5	3	4	5
McMullin and Merrick (2002) Test 1 (a)	0	235	225	205	176	149	138			
McMullin and Merrick (2002) Test 6 (b)	0	190	202	210	209	197	153	141	115	
McMullin and Merrick (2002) Test 7 (b)	0	159	169	174	151	146	128	123	77	
McMullin and Merrick (2002) Test 11 (c)	0	225	254	225	205	197	186	170	128	
Pardoen et al. (2003) Test 19A (d)	0	131	125	115	102	92	77	73	69	
Pardoen et al. (2003) Test 19B (d)	0	121	115	102	88	86	83	78	71	
City of Los Angeles (2001) Test 8A (e)	0	198	175	139	125	109				
City of Los Angeles (2001) Test 8B (e)	0	165	131	108	101					
Schmid (2001) Panel 6B (f)	0	230	271	271						
Average	0	202	213	204	185	172	151	145	107	
Standard deviation	0	35	36	21	27	29	25	24	27	
Covariance (COV)	0	17%	17%	11%	15%	17%	17%	16%	25%	
Average + 1 standard deviation	0	237	248	225	212	201	177	168	133	
Average - 1 standard deviation	0	168	177	182	158	144	126	121	80	
Beta		0.17	0.17	0.10	0.15	0.16	0.17	0.16	0.24	
Recommended Beta		0.30	0.30	0.30	0.30	0.30	0.30	0.30	0.30	
ASCE/SEI 41, <i>Seismic Rehabilitation of Existing Buildings</i> (default properties)	Drift Ratio (%)									
	0	0.07	0.4	0.4	0.44					
	0	67	100	20	20					
American Forest and Paper Association, <i>Special Design Provisions for Wind and Seismic</i>	Drift Ratio (%)									
	0	0.14	0.22							
	0	60	96							
(a) Cyclic testing, CUREE protocol. Fastened with nails at 8". Door opening.										
(b) Cyclic testing, CUREE protocol. Fastened with screws at 16 inches on center. Average positive and negative quadrant. Door opening.										
(c) Cyclic testing, CUREE protocol. Fastened with screws at 16". Door and window opening.										
(d) Cyclic testing, CUREE protocol. Fastened with #6 screw at 6". Door opening.										
(e) Cyclic testing, Sequential Phased Displacement (SPD) protocol. No openings.										
(f) Cyclic testing, SPD protocol. Fastened with nails at 7". No openings.										

Gray cells not included in average, beta

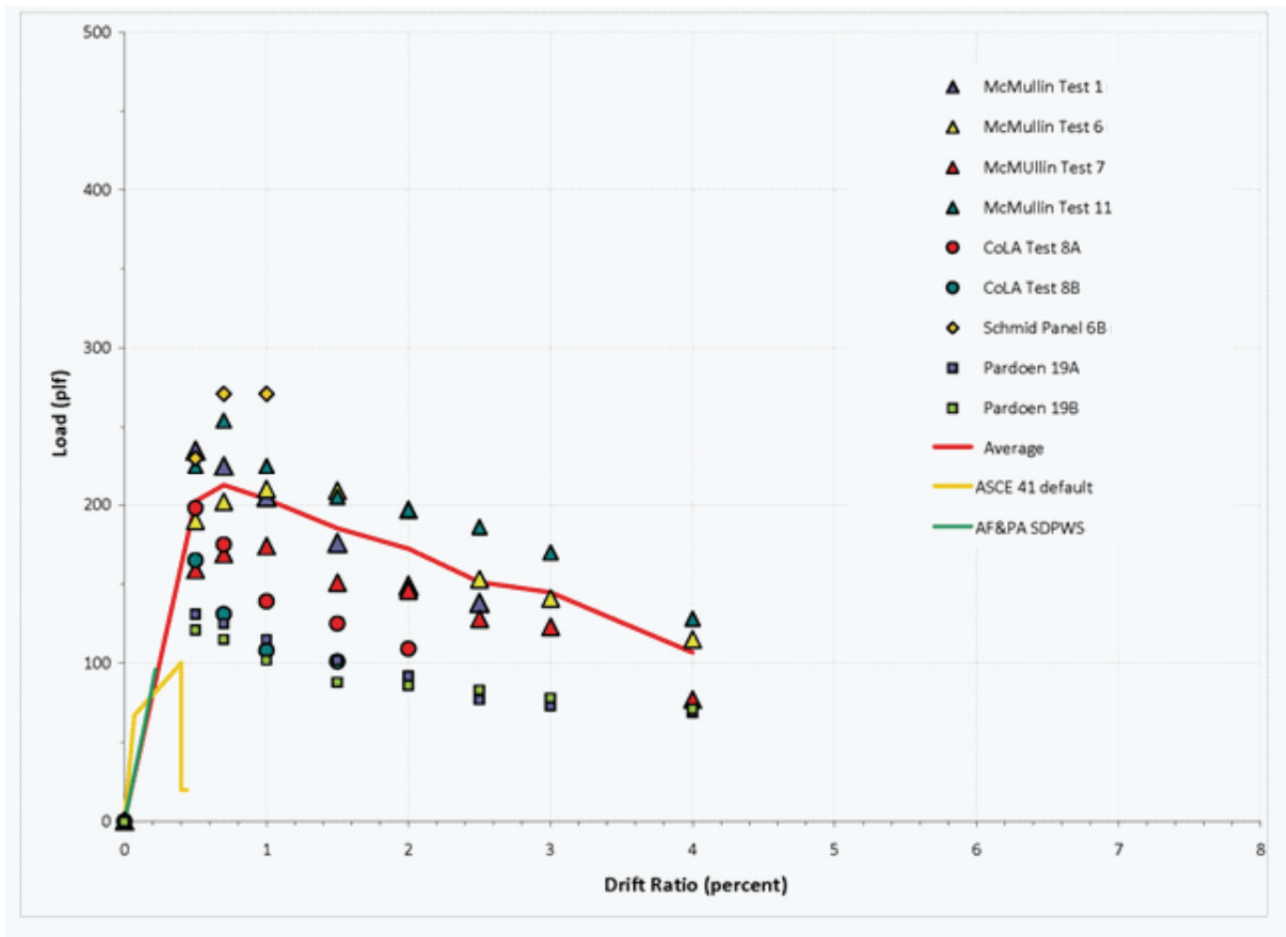

Figure D-5 Load-drift data for gypsum wallboard. CoLA = City of Los Angeles. AF&PA SDPWS = American Forest and Paper Association, *Special Design Provisions for Wind and Seismic*. Additional information on testing procedures for each data source is provided in Table D-5.

D.3.6 Plaster on Gypsum Lath

Table D-6 and Figure D-6 illustrate information available for quantification of load-drift behavior for plaster on gypsum lath. As previously described two tests by Schmid (2001) are available. The tests have varying boundary conditions, resulting in widely varying capacities. Both tests were considered equally applicable, and the average of the tests was recommended for use in estimating load-deflection behavior. ASCE/SEI 41 default properties are shown for comparison; the ASCE/SEI 41 properties are significantly outside of the entire range of tests. A beta of 0.45 is recommended based on the combinations of low number of tests and high variability.

Table D-6 Load-Drift Data for Plaster on Gypsum Lath

Sheathing Shear Capacities (plf)										
Data Source / Type	Drift Ratio (%)									
	0	0.5	0.7	1	1.5	2	2.5	3	4	5
Schmid (2001) Panel 3 (a)	0	512	443	304						
Schmid (2001) Panel 7B (b)	0	292	250							
Average	0	402	347	304						
Standard deviation	0	156	136							
Covariance (COV)	0	39%	39%							
Average + 1 Standard deviation	0	558	483							
Average - Standard deviation	0	246	210							
Beta		0.37	0.38							
Recommended Beta		0.45	0.45							
ASCE/SEI 41, <i>Seismic Rehabilitation of Existing Buildings</i> (default properties)	Drift Ratio (%)									
	0	0.04	0.2	0.2	0.24					
	0	53	80	16	16					
(a) Cyclic testing, Sequential Phased Displacement (SPD) protocol. Confined at all boundaries.										
(b) Cyclic testing, SPD protocol. Confined at wall top only.										

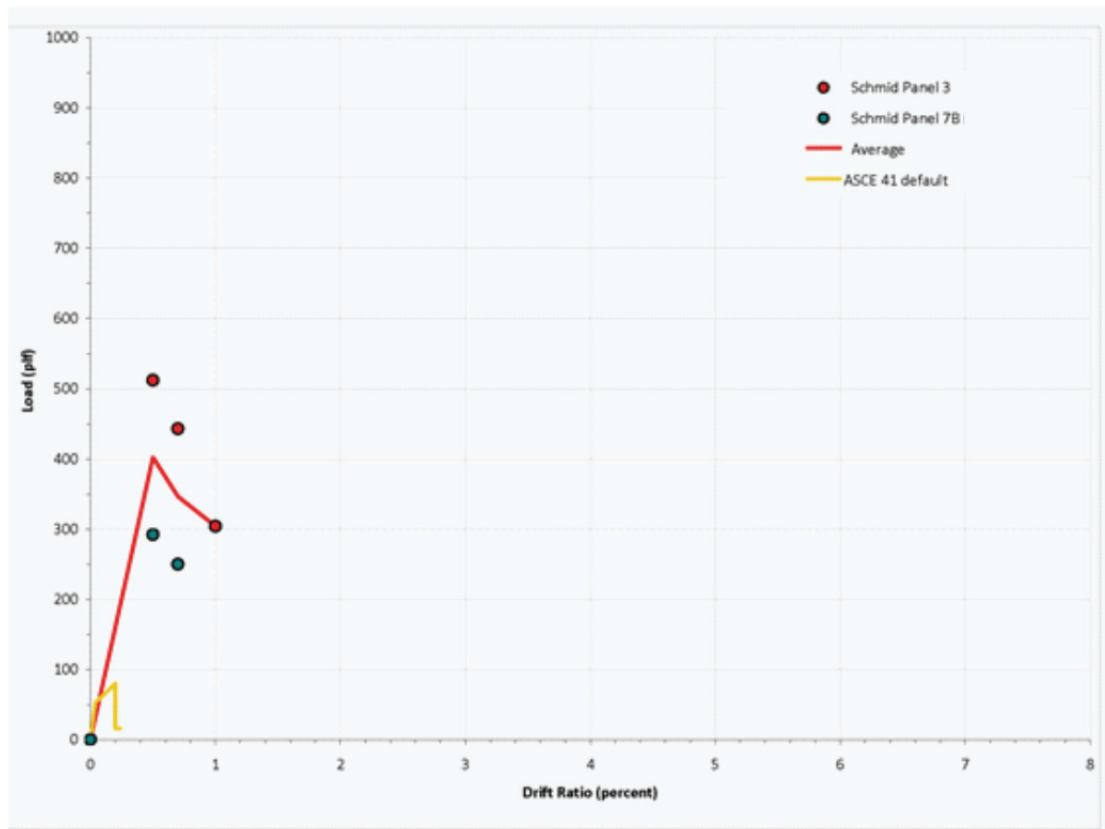

Figure D-6 Load-drift data for plaster on gypsum lath. Additional information on testing procedures for each data source is provided in Table D-6.

D.3.7 Wood Structural Panel Siding

Table D-7 and Figure D-7 illustrate information available for quantification of load-drift behavior for wood structural panel siding. Available information was limited to peak capacities reported by American Plywood Association (APA) from one test with 5/16" panel and one with a 3/8" panel. The shape of the load-deflection curve shown was taken from the wood structural panel testing with 8d@6 inches on center nailing discussed below and adjusted for the APA reported peak capacities for wood structural panel siding and 6d@6 nailing. A beta of 0.15 has been recommended for the entire range of wood

Table D-7 Load-Drift Data for Wood Structural Panel Siding

Sheathing Shear Capacities (plf)										
Data Source / Type	Drift Ratio (%)									
	0	0.5	0.7	1	1.5	2	2.5	3	4	5
APA (1993) 5/16" panel WSP Siding 6d@6 (a)	0	452	496	588	639	650	580	517		
APA (1993) 3/8" panel WSP Siding 6d@6 (a)	0	256	345	404	460	480	429	381		
Average	0	354	420	496	549	565	505	449		
Recommended Beta		0.15	0.15	0.15	0.15	0.15	0.15	0.15		

(a) APA testing with casing nails. Peak capacity known (650 plf at 2% drift); balanced proportioned from 8d@6.

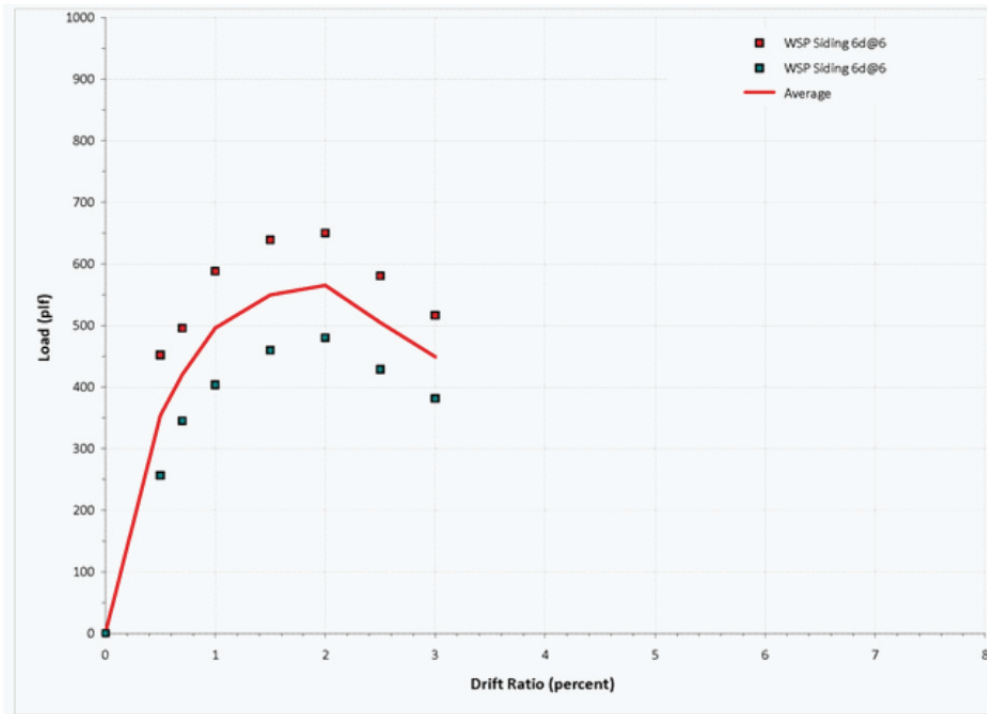

Figure D-7 Load-drift data for wood structural panel siding (5/16" and 3/8" thickness). Additional information on testing procedures for each data source is provided in Table D-7.

structural panel sheathed shear walls based on our better knowledge of this shear-wall group.

D.3.8 Wood Structural Panel Sheathing

Tables D-8 through D-12 and Figures D-8 through D-12 illustrate information available for quantification of load-drift behavior for wood structural panel shear walls with varying nailing. Available information includes four tests using the CUREE protocol and Sequential Phased Displacement (SPD) protocols, a combination of rated sheathing and Structural I sheathing, and a combination of box nails and common nails. CUREE testing suggested that the sheathing (Structural versus rated sheathing) and nail type (common versus box) differences have only minor impact on the peak capacity and deflection at peak capacity of the walls, with Structural I sheathing providing slightly higher capacities than rated sheathing, and box nails providing slightly lower capacity than common nails. The differences in capacities were small enough that differentiation of load-drift behavior is not recommended. The SPD protocol was demonstrated by Gatto and Uang to significantly impact capacity and deflection of wood structural panel shear walls. For this reason, City of Los Angeles (CoLA) tests are converted using conversion factors derived by Gatto and Uang. ASCE/SEI 41 default properties are shown for comparison; of note is that for a number of materials the tests show considerably more displacement capacity than currently considered by ASCE/SEI 41. A beta of 0.15 has been recommended for the entire range of wood structural panel sheathed shear walls based on calculated betas and our better knowledge of this shear wall group.

Following the 1994 Northridge earthquake, building code requirements for 3x studs at abutting wood structural panel sheathing edges and 3x foundation sill plates were added for moderate- to high-capacity shear walls, as were requirements for steel-plate washers on anchor bolts. The requirements for 3x foundation sill plates have since been removed from the code. In general, it is intended that recommended shear-wall load-drift behavior can be modeled without consideration of whether this detailing is provided. Two exceptions are recommended for wood structural panel sheathed shear walls. First, where 2x studs are used at abutting panel edges in combination with 8d or 10d nails spaced three inches on center or closer, it is recommended that the peak drift capacity of the shear wall be reduced to approximately two inches, as stud splitting has been seen to occur at higher drift levels. In addition, where significant overturning uplift is anticipated to occur in wood structural panel shear walls and steel-plate washers are not used, consideration should be given to adjustment of wall peak capacity based on possible foundation sill plate splitting at anchor bolts. Refer to Mahaney and Kehoe (2002) for

further information on both exceptions. Where retrofitting or addition of shear walls is to occur, it is intended that such retrofitted or added shear walls conform to all detailing requirements of the applicable building code or standard.

Wood Structural Panel 8d@6

Table D-8 and Figure D-8 illustrate information available for quantification of load-drift behavior for wood structural panel shear walls with 8d@6”

Table D-8 Load-Drift Data for Wood Structural Panel 8d@6

Sheathing Shear Capacities (plf)										
Data Source / Type	Drift Ratio (%)									
	0	0.5	0.7	1	1.5	2	2.5	3	4	5
Pardoen et al. (2003) Test 4A (a)	0	430	508	595	693	722	722	722		
Pardoen et al. (2003) Test 4B (a)	0	517	592	670	762	762	739	716		
Pardoen et al. (2003) Test 6A (b)	0	769	778	901	949	974	613	589		
Pardoen et al. (2003) Test 6B (b)	0	517	595	673	745	805	723	641	589	
City of Los Angeles (COLA) (2001) Test 1A (c)	0	551	625	706	706	544				
CoLA (2001) Test 1B (c)	0	485	544	589	610	544				
CoLA (2001) Test 1A converted (d)	0	476	666	831	939	939	886	724		
CoLA (2001) Test 1B converted (d)	0	419	586	724	783	811	790	724		
Average (w/converted)	0	521	621	732	812	836	745	686		
Standard deviation	0	128	92	114	107	100	90	57		
Covariance (COV)	0	25%	15%	16%	13%	12%	12%	8%		
Average + 1 std dev	0	650	713	846	919	935	835	743		
Average - 1 std dev	0	393	529	619	705	736	656	628		
Beta		0.24	0.15	0.15	0.13	0.12	0.12	0.08		
Recommended Beta		0.15	0.15	0.15	0.15	0.15	0.15	0.15		
ASCE/SEI 41, <i>Seismic Rehabilitation of Existing Buildings</i> (default properties)	Drift Ratio (%)									
	0	0.2	0.9	0.9	1.1					
	0	320	480	144	144					
CoLA (2001) Testing Converted:	Drift Ratio (%)									
	0	0.77	1.078	1.54	2.31	3.08	3.85	4.62	6.16	7.7
CoLA (2001) Test 1A	0	732.83	831.25	938.98	938.98	723.52	0	0	0	0
CoLA (2001) Test 1B	0	645.05	723.52	783.37	811.3	723.52	0	0	0	0
(a) Cyclic testing, CUREE protocol. No openings. 8db (box nails) at 6".										
(b) Cyclic testing, CUREE protocol. Pedestrian door opening. 8db at 6".										
(c) Cyclic testing, Sequential Phased Displacement (SPD) protocol. No openings. 8dc (common nails) at 6"										
(d) Cyclic testing, SPD protocol adjusted to CUREE (see row labeled "CoLA Testing Converted"). No openings. 8dc at 6"										

Gray cells not included in average, beta

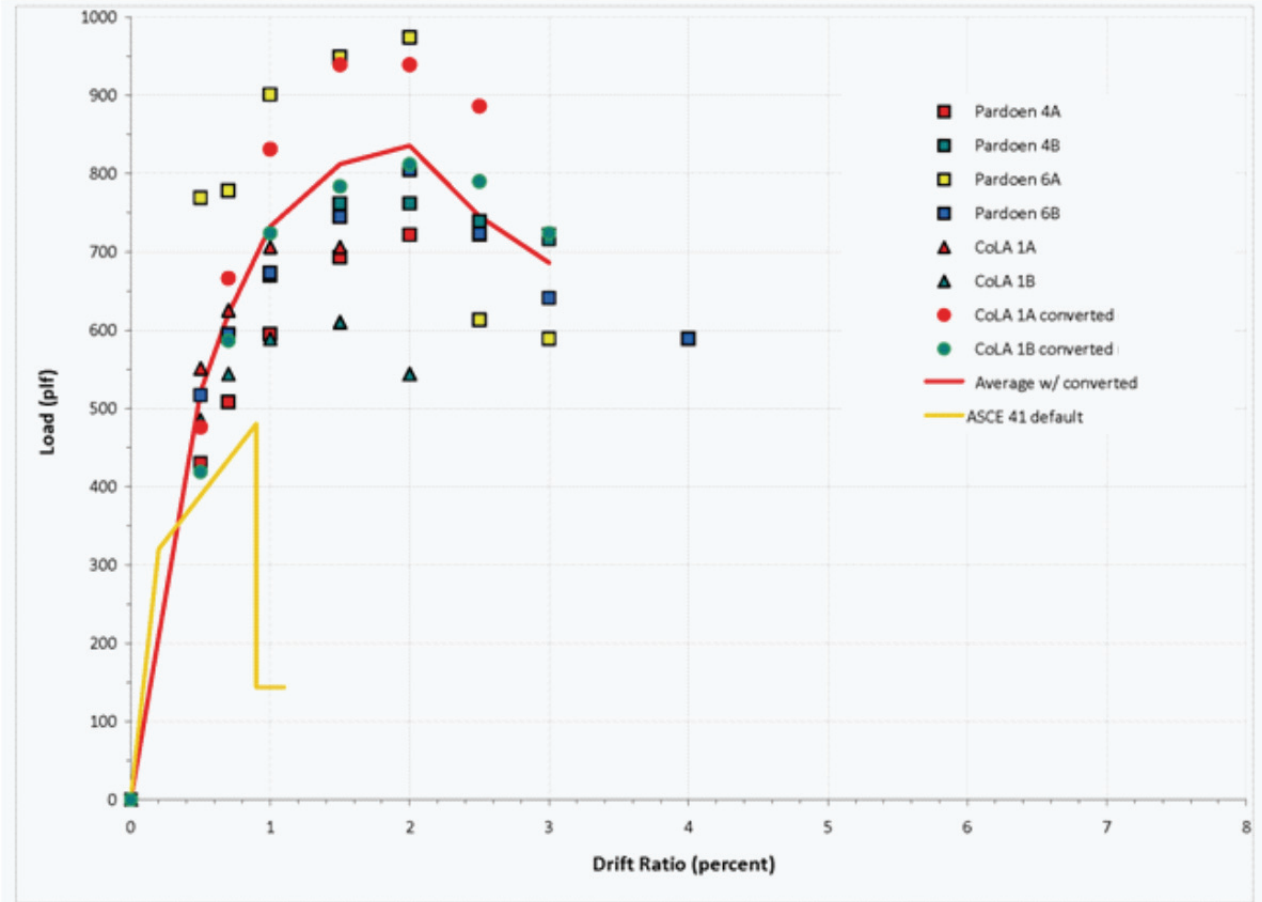

Figure D-8 Load-drift data for wood structural panel 8d@6. CoLA = City of Los Angeles. Additional information on testing procedures for each data source is provided in Table D-8.

nailing. Available information includes four tests by Pardoen et al. (2003) using the CUREE protocol and two tests by the City of Los Angeles (CoLA) using the SPD protocol. CoLA tests are converted using the protocol conversion factors derived by Gatto and Uang. The Pardoen et al. (2003) tests and converted CoLA tests were considered equally applicable, and the average of the tests was used in estimating load-deflection behavior.

Wood Structural Panel 8d@4

Table D-9 and Figure D-9 illustrate information available for quantification of load-drift behavior for wood structural panel walls with 8d@4 nailing. Available information includes two tests by Gatto and Uang using the CUREE protocol and two tests by the City of Los Angeles (CoLA) using the Sequential Phased Displacement (SPD) protocol. CoLA tests are converted using conversion factors derived by Gatto and Uang. The Gatto & Uang tests and converted CoLA tests were considered equally applicable, and the average of the tests was recommended for use in estimating load deflection behavior.

Table D-9 Load-Drift Data for Wood Structural Panel 8d@4

Sheathing Shear Capacities (plf)										
Data Source / Type	Drift Ratio (%)									
	0	0.5	0.7	1	1.5	2	2.5	3	4	5
Gatto & Uang (2002) Test 2 (a)	0	432	514	616	756	885	958	1009	870	
Gatto & Uang (2002) Test 6 (b)	0	456	592	682	785	886	993	1031	1051	983
City of Los Angeles (CoLA) (2001) Test 2A (c)	0	678	759	859	914	927	475			
CoLA (2001) Test 2B (c)	0	669	750	818	851	885	481			
CoLA (2001) Test 2A converted (d)	0	586	820	1009	1142	1186	1222	1233	632	
CoLA (2001) Test 2B converted (d)	0	578	809	998	1088	1114	1149	1177	640	
Average (w/converted)	0	513	684	826	943	1018	1080	1112	798	
Standard deviation	0	80	154	206	201	156	126	110	201	
Covariance (COV)	0	16%	23%	25%	21%	15%	12%	10%	25%	
Average + 1 standard deviation	0	593	838	1033	1143	1173	1206	1222	1000	
Average - 1 standard deviation	0	433	529	620	742	862	955	1003	597	
Beta		0.16	0.22	0.25	0.21	0.15	0.12	0.10	0.25	
Recommended Beta		0.15	0.15	0.15	0.15	0.15	0.15	0.15	0.15	
ASCE/SEI 41, <i>Seismic Rehabilitation of Existing Buildings</i> (default properties)	Drift Ratio (%)									
	0	0.2	0.9	0.9	1.1					
	0	467	700	210	210					
CoLA (2001) Testing Converted:	Drift Ratio (%)									
	2.5	0.77	1.078	1.54	2.31	3.08	3.85	4.62	6.16	7.7
CoLA (2001) Test 2A converted (d)	0	902	1009	1142	1216	1233	632	0	0	0
CoLA (2001) Test 2B converted (d)	0	890	998	1088	1132	1177	640	0	0	0
(a) Cyclic testing, CUREE protocol. No openings. Plywood 8db (box nails) at 4". Average positive and negative quadrant.										
(b) Cyclic testing, CUREE protocol. No openings. OSB 8db at 4". Average positive and negative quadrant.										
(c) Cyclic testing, Sequential Phased Displacement (SPD) protocol. No openings. Str-I plywood 8dc (common nails) at 4".										
(d) Cyclic testing, SPD protocol converted to CUREE). No openings. Str I plywood 8dc at 4".										

Gray cells not included in average

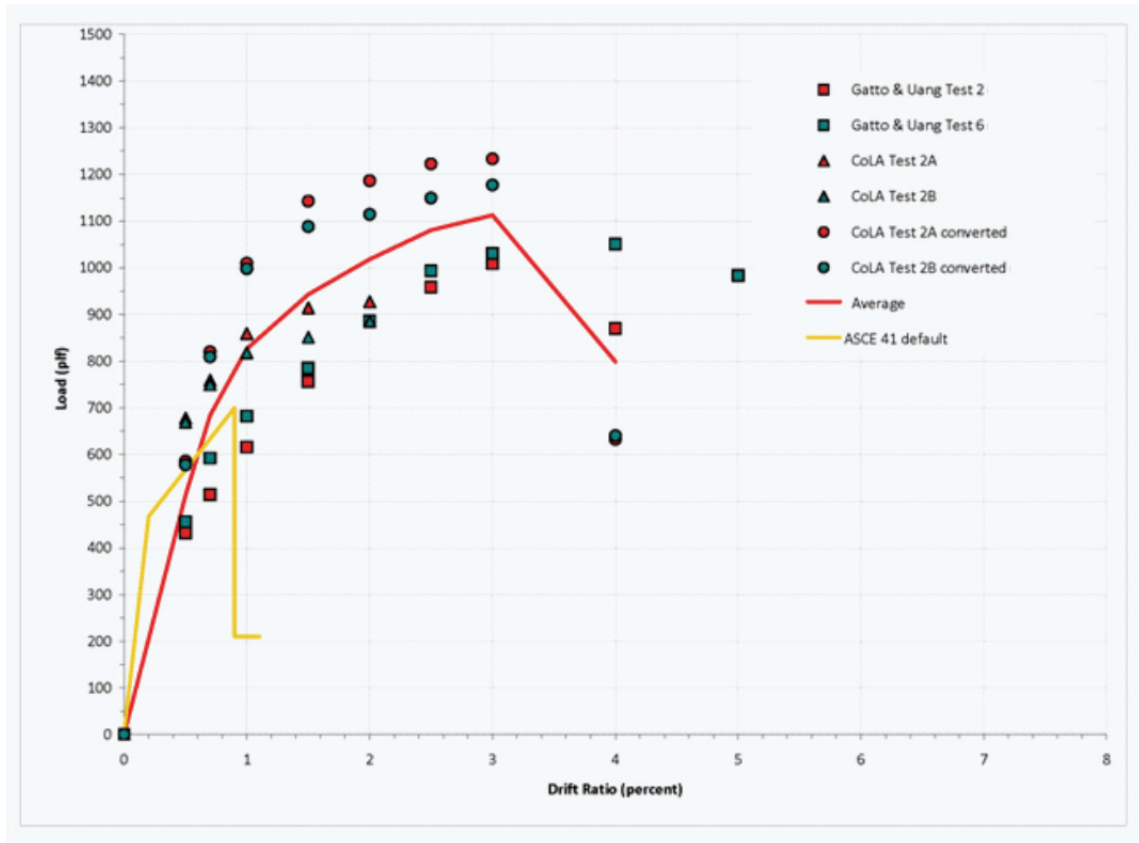

Figure D-9 Load-drift data for wood structural panel 8d@4. CoLA = City of Los Angeles. Additional information on testing procedures for each data source is provided in Table D-9.

Wood Structural Panel 8d@3

Table D-10 and Figure D-10 illustrate information available for quantification of load-drift behavior for wood structural panel walls with 8d@3 nailing. Available information includes four tests by Pardoen et al. (2003) using the CUREE protocol. The Pardoen et al. (2003) tests used 16-ft-long walls with a 10-ft garage opening, resulting in two 3-ft wall piers. As seen in Figure D-10, this resulted in the shear walls having a higher deflection at peak capacity than other comparable walls. Current design standards would require adjustments of allowable unit shears for deformation compatibility for these walls based on the high aspect ratio. For this reason, the Pardoen et al. (2003) tests were converted using aspect ratio conversion factors specified in the *International Building Code* (IBC) and American Forest and Paper Association, *Special Design Provisions for Wind and Seismic* (AF&PA SDPWS), as shown at the bottom of Table D-10. This brought the drift at peak capacity down to three inches. The four converted Pardoen et al. (2003) tests were considered equally applicable, and the average of the tests was used in estimating load deflection behavior.

Table D-10 Load-Drift Data for Wood Structural Panel 8d@3

Sheathing Shear Capacities (plf)										
Data Source / Type	Drift Ratio (%)									
	0	0.5	0.7	1	1.5	2	2.5	3	4	5
Pardoen et al. (2003) Test 8A (a)	0	833	1028	1158	1288	1420	1523	1588	1666	1693
Pardoen et al. (2003) Test 8B (a)	0	833	1003	1185	1342	1458	1588	1640	1667	1563
Pardoen et al. (2003) Test 10A (b)	0	1055	1212	1315	1472	1563	1667	1718	1718	1667
Pardoen et al. (2003) Test 10B (b)	0	990	1158	1215	1367	1485	1588	1667	1693	1630
Pardoen et al. (2003) Test 8A adjusted for aspect ratio (c)	0	996	1132	1245	1420	1545	1614	1666	1693	
Pardoen et al. (2003) Test 8B adjusted for aspect ratio (c)	0	975	1149	1290	1458	1605	1649	1667	1563	
Pardoen et al. (2003) Test 10A adjusted for aspect ratio (d)	0	1186	1294	1420	1563	1684	1718	1718	1667	
Pardoen et al. (2003) Test 10B adjusted for aspect ratio (d)	0	1130	1204	1316	1485	1614	1676	1693	1630	
Average	0	1072	1195	1318	1482	1612	1664	1686	1638	
Standard deviation	0	103	73	74	61	57	44	25	56	
Covariance (COV)	0	10%	6%	6%	4%	4%	3%	1%	3%	
Average + 1 standard deviation	0	1174	1268	1392	1542	1669	1708	1711	1695	
Average - 1 standard deviation	0	969	1121	1243	1421	1555	1620	1661	1582	
Beta		0.10	0.06	0.06	0.04	0.04	0.03	0.01	0.03	
Recommended Beta		0.15	0.15	0.15	0.15	0.15	0.15	0.15	0.15	
ASCE/SEI 41, <i>Seismic Rehabilitation of Existing Buildings</i> (default properties)	Drift Ratio (%)									
	0	0.21	1	1	1.2					
	0	600	900	270	270					
Aspect Ratio Adjustments:	Drift Ratio (%)									
	0	0.375	0.525	0.75	1.125	1.5	1.875	2.25	3	3.75
Pardoen et al. (2003) Test 8A adjusted for aspect ratio	0	833	1028	1158	1288	1420	1523	1588	1666	1693
Pardoen et al. (2003) Test 8B adjusted for aspect	0	833	1003	1185	1342	1458	1588	1640	1667	1563
Pardoen et al. (2003) Test 10A adjusted for aspect	0	1055	1212	1315	1472	1563	1667	1718	1718	1667
Pardoen et al. (2003) Test 10B adjusted for aspect	0	990	1158	1215	1367	1485	1588	1667	1693	1630
	0	0.5	0.7	1	1.5	2	2.5	3	4	5
Pardoen et al. (2003) Test 8A adjusted for aspect ratio	0	996	1132	1245	1420	1545	1614	1666	1693	
Pardoen et al. (2003) Test 8B adjusted for aspect	0	975	1149	1290	1458	1605	1649	1667	1563	
Pardoen et al. (2003) Test 10A adjusted for aspect	0	1186	1294	1420	1563	1684	1718	1718	1667	
Pardoen et al. (2003) Test 10B adjusted for aspect	0	1130	1204	1316	1485	1614	1676	1693	1630	
(a) Cyclic testing, CUREE protocol. Garage door opening. OSB 8d box at 3".										
(b) Cyclic testing, CUREE protocol. Garage door opening. OSB 8d common at 3".										
(c) Cyclic testing, CUREE protocol. Garage door opening. OSB 8d box at 3", adjusted for aspect ratio.										
(d) Cyclic testing, CUREE protocol. Garage door opening. OSB 8d common at 3", adjusted for aspect ratio.										

Gray cells not used in average, beta

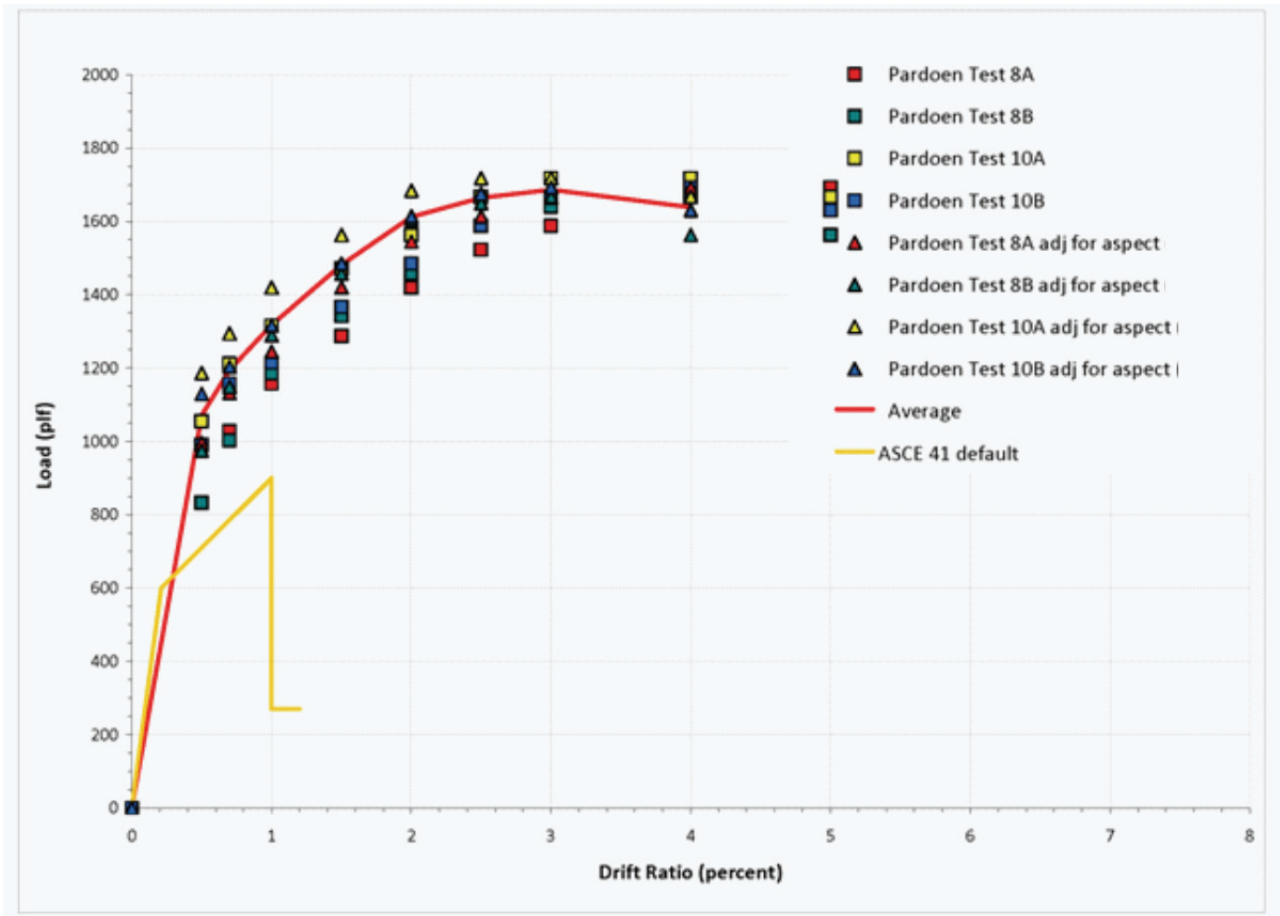

Figure D-10 Load-drift data for wood structural panel 8d@3. Additional information on testing procedures for each data source is provided in Table D-10.

Wood Structural Panel 10d@6

Table D-11 and Figure D-11 illustrate information available for quantification of load-drift behavior for wood structural panel walls with 10d@6 nailing. Available information includes two tests by the City of Los Angeles (CoLA) using the Sequential Phased Displacement (SPD) protocol. CoLA tests are converted using conversion factors derived by Gatto and Uang. The converted CoLA tests were considered equally applicable, and the average of the tests was recommended for use in estimating load deflection behavior.

Table D-11 Load-Drift Data for Wood Structural Panel 10d@6

Sheathing Shear Capacities (plf)										
Data Source / Type	Drift Ratio (%)									
	0	0.5	0.7	1	1.5	2	2.5	3	4	5
City of Los Angeles (CoLA) (2001) Test 3A (a)	0	636	709	773	795	819	636			
CoLA (2001) Test 3B (a)	0	632	714	765	782	782	632			
CoLA (2001) Test 3A converted (b)	0	549	769	943	1028	1045	1069	1089	846	
CoLA (2001) Test 3B converted (b)	0	546	764	950	1017	1031	1040	1040	841	
Average (w/converted)	0	548	767	946	1023	1038	1055	1065	843	
Standard deviation	0	2	3	5	8	10	21	35		
Covariance (COV)	0	0%	0%	0%	1%	1%	2%	3%		
Average + 1 standard deviation	0	550	770	951	1030	1048	1075	1099		
Average - 1 standard deviation	0	545	763	942	1015	1028	1034	1030		
Beta		0.00	0.00	0.00	0.01	0.01	0.02	0.03		
Recommended Beta		0.15	0.15	0.15	0.15	0.15	0.15	0.15		
ASCE/SEI 41, <i>Seismic Rehabilitation of Existing Buildings</i> (default properties)	Drift Ratio (%)									
	0	0.31	1.4	1.4	1.7					
	0	413	620	186	186					
CoLA (2001) Testing Converted:	Drift Ratio (%)									
	0	0.77	1.078	1.54	2.31	3.08	3.85	4.62	6.16	7.7
	0	846	943	1028	1057	1089	846			
CoLA (2001) Test 3B converted (b)	0	841	950	1017	1040	1040	841			

(a) Cyclic testing, Sequential Phased Displacement (SPD) protocol. No openings. Str-I plywood 8dc (common nails) at 4".

(b) Converted to CUREE protocol.

Gray cells not included in average

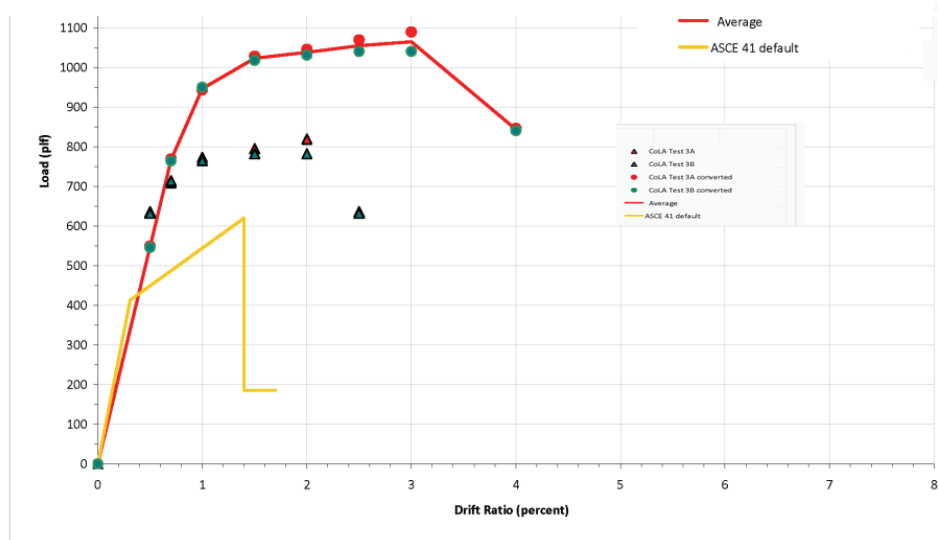

Figure D-11 Load-drift data for wood structural panel 10d@6. CoLA = City of Los Angeles. Additional information on testing procedures for each data source is provided in Table D-11.

Wood Structural Panel 10d@4

Table D-12 and Figure D-12 illustrate information available for quantification of load-drift behavior for wood structural panel walls with 10d@4 nailing. Available information includes two tests by the City of Los Angeles (CoLA) using the Sequential Phased Displacement (SPD) protocol. CoLA tests are converted using conversion factors derived by Gatto and Uang. The converted CoLA tests were considered equally applicable, and the average of the tests was used in estimating load deflection behavior.

Table D-12 Load-Drift Data for Wood Structural Panel 10d@4

Sheathing Shear Capacities (plf)										
Data Source / Type	Drift Ratio (%)									
	0	0.5	0.7	1	1.5	2	2.5	3	4	5
City of Los Angeles (CoLA) (2001) Test 4A (a)	0	732	884	1025	1116	1216	1116			
CoLA (2001) Test 4B (a)	0	905	1034	1111	1134	1034	666			
CoLA (2001) Test 4A converted (b)	0	632	885	1176	1363	1436	1534	1617	1484	
CoLA (2001) Test 4B converted (b)	0	782	1094	1375	1478	1496	1458	1375	886	
Average (w/converted)	0	707	990	1275	1420	1466	1496	1496	1185	
Standard deviation	0	106	148	141	81	43	54	171		
Covariance (COV)	0	15%	15%	11%	6%	3%	4%	11%		
Average + 1 standard deviation	0	813	1138	1417	1501	1508	1550	1667		
Average - 1 standard deviation	0	601	842	1134	1340	1423	1442	1325		
Beta		0.15	0.15	0.11	0.06	0.03	0.04	0.11		
Recommended Beta		0.15	0.15	0.15	0.15	0.15	0.15	0.15		
ASCE/SEI 41, <i>Seismic Rehabilitation of Existing Buildings</i> (default properties)	Drift Ratio (%)									
	0	0.39	1.7	1.7	2					
	0	647	970	290	290					
CoLA Testing Converted:	Drift Ratio (%)									
	0	0.77	1.078	1.54	2.31	3.08	3.85	4.62	6.16	7.7
CoLA (2001) Test 4A converted (b)	0	974	1176	1363	1484	1617	1484			
CoLA (2001) Test 4B converted (b)	0	1204	1375	1478	1508	1375	886			
(a) Cyclic testing, Sequential Phased Displacement (SPD) protocol. No openings. Str-I plywood 8dc (common nails) at 4".										
(b) Converted to CUREE protocol.										

Gray cells not included in average

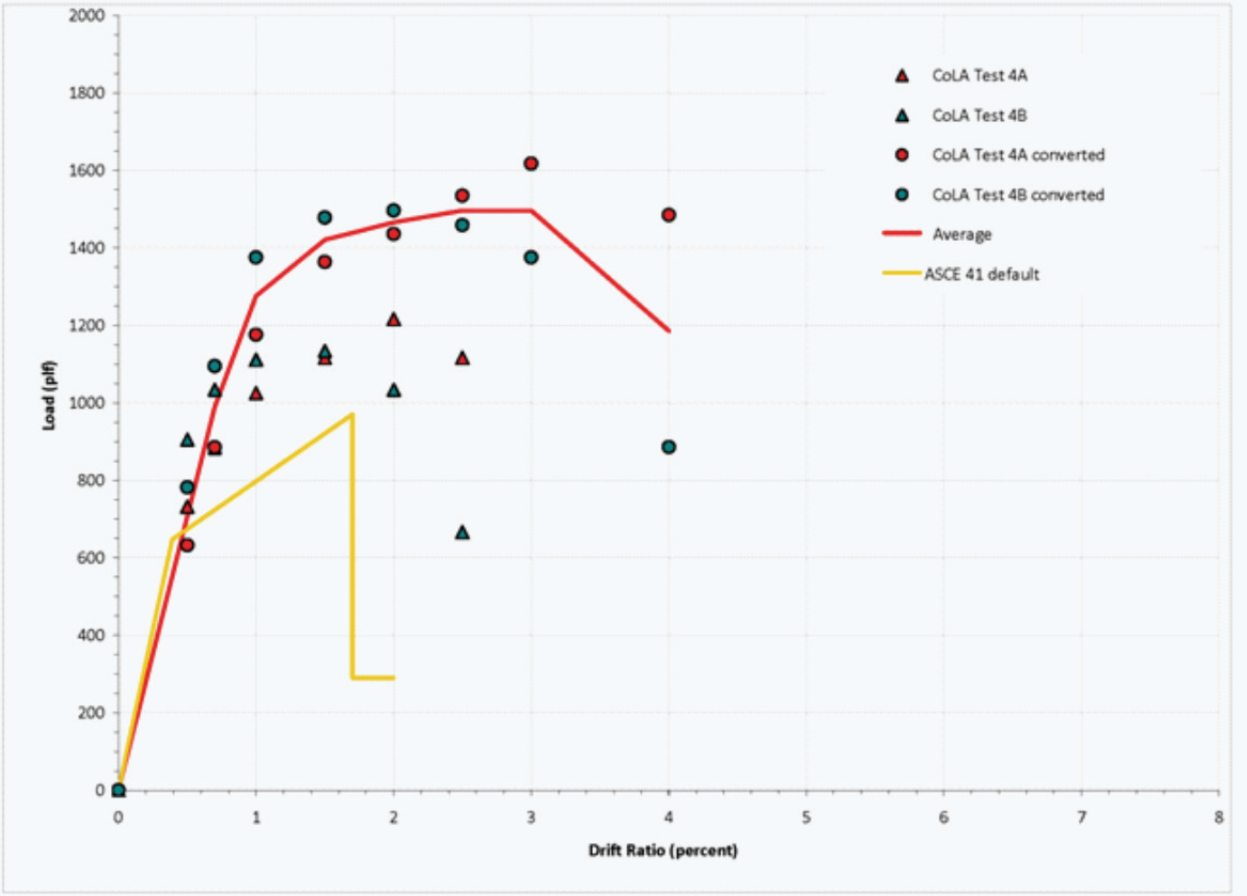

Figure D-12 Load-drift data for wood structural panel 10d@4. CoLA = City of Los Angeles. Additional information on testing procedures for each data source is provided in Table D-12.

Wood Structural Panel 10d@2

Table D-13 and Figure D-13 illustrate information available for quantification of load-drift behavior for wood structural panel walls with 10d@2 nailing. Available information includes four tests by the City of Los Angeles (CoLA) using the Sequential Phased Displacement (SPD) protocol. CoLA tests are converted using conversion factors derived by Gatto and Uang. The converted CoLA tests were considered equally applicable, and the average of the tests was used in estimating load deflection behavior.

Table D-13 Load-Drift Data for Wood Structural Panel 10d@2

Sheathing Shear Capacities (plf)										
Data Source / Type	Drift Ratio (%)									
	0	0.5	0.7	1	1.5	2	2.5	3	4	5
City of Los Angeles (CoLA) (2001) Test 9A (a)	0	1197	1436	1655	1859	1863	1683	1258		
CoLA (2001) Test 9C (a)	0	1197	1436	1585	1859	1907	1834	1430		
CoLA (2001) Test 13B (a)	0	1397	1552	1726	1878	1840	954			
CoLA (2001) Test 13C (a)	0	1397	1587	1795	1958	1946	1640			
CoLA (2001) Test 9A converted (b)	0	1033	1447	1910	2201	2363	2474	2477	2128	
CoLA (2001) Test 9C converted (b)	0	1033	1447	1910	2108	2325	2496	2536	2334	
CoLA (2001) Test 13B converted (b)	0	1207	1690	2064	2295	2416	2478	2447		
CoLA (2001) Test 13C converted (b)	0	1207	1690	2110	2388	2517	2598	2588		
Average (w/converted)	0	1120	1568	1999	2248	2405	2512	2512	2231	
Standard deviation	0	100	140	104	120	83	58	63		
Covariance (COV)	0	9%	9%	5%	5%	3%	2%	2%		
Average + 1 standard deviation	0	1220	1708	2103	2368	2489	2570	2575		
Average - 1 standard deviation	0	1020	1428	1895	2127	2322	2453	2449		
Beta		0.09	0.09	0.05	0.05	0.03	0.02	0.02		
Recommended Beta		0.15	0.15	0.15	0.15	0.15	0.15	0.15		
ASCE/SEI 41, <i>Seismic Rehabilitation of Existing Buildings</i> - Plywood (default properties)		Drift Ratio (%)								
	0	0.36	1.6	1.6	2					
	0	1030	1540	462	462					
ASCE/SEI 41 - OSB (default properties)	0	0.16	0.7	0.7	0.9					
	0	1030	1540	462	462					
		Drift Ratio								
CoLA (2001) Testing Converted:-	0	0.77	1.078	1.54	2.31	3.08	3.85	4.62	6.16	7.7
CoLA (2001) Test 9A converted (b)	0	1592	1910	2201	2472	2477	2238	1674		
CoLA (2001) Test 9C converted (b)	0	1592	1910	2108	2472	2536	2439	1902		
CoLA (2001) Test 13B converted (b)	0	1859	2064	2295	2498	2447	1268	0		
CoLA (2001) Test 13C converted (b)	0	1859	2110	2388	2605	2588	2181	0		
(a) Cyclic testing, Sequential Phased Displacement (SPD) protocol. No openings. Str-I plywood, OSB 8dc at 2".										
(b) Converted to CUREE protocol.										

Gray cells not included in average

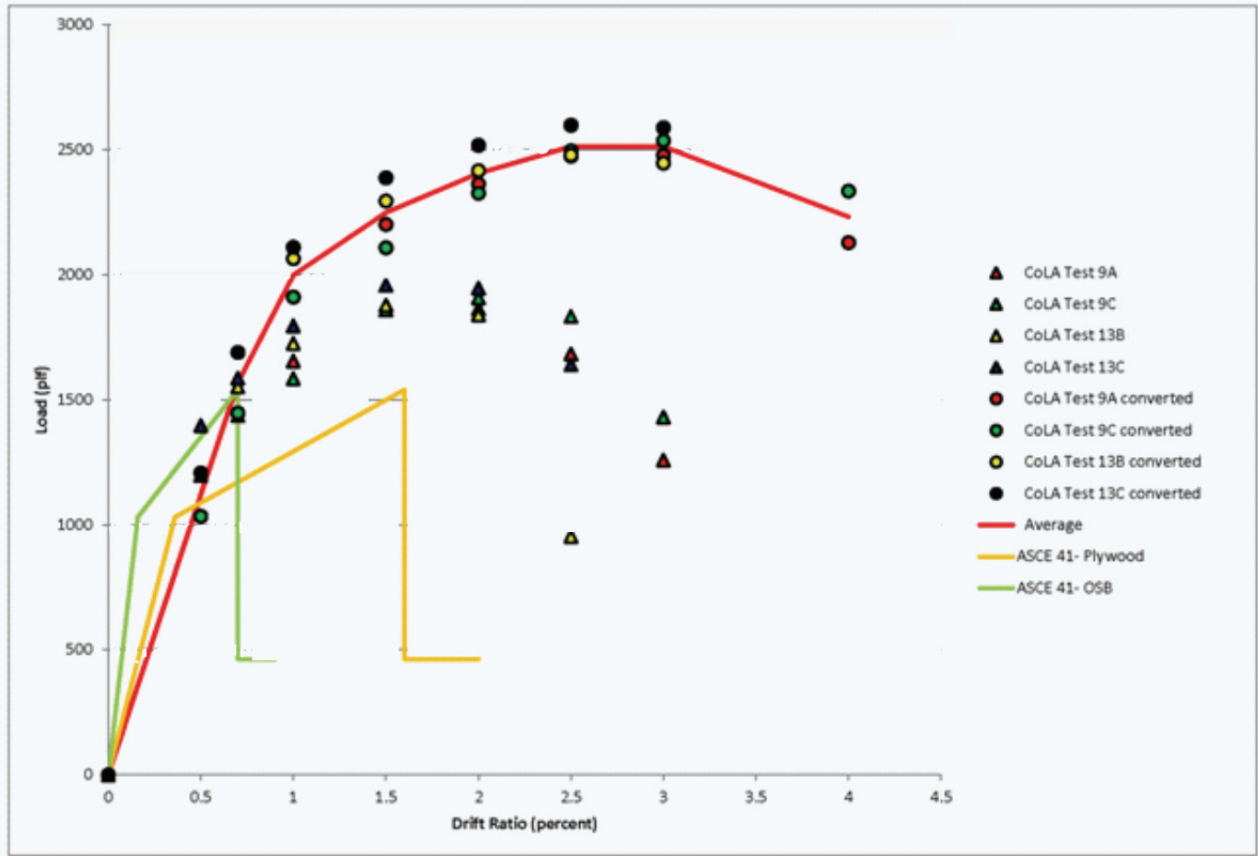

Figure D-13 Load-drift data for wood structural panel 10d@2. CoLA = City of Los Angeles. Additional information on testing procedures for each data source is provided in Table D-13.

D.4 Recommended Descriptions of Wall Bracing Materials

This section presents recommendations that were made for describing wall bracing material load-deflection behavior for this *Guidelines* document. The recommendations are based on Section D.3 data, Table D-14 provides estimated mean capacities at specified drift levels ranging between 0.5 and 4 percent of the wall height. Also tabulated are recommended beta values for the variability of the capacity. The beta values are intended to apply at all drift levels. See other sections of these *Guidelines* for a description of how this information was used in developing the retrofit solutions.

Table D-14 Recommended Values for Estimated Capacity and Variability

Material	Beta	Estimated Mean Capacity (plf) at Specified Drift Level (% height)							
		0.5	0.7	1	1.5	2	2.5	3	4
Stucco	0.45	333	320	262					
Horizontal Lumber Sheathing	0.15	85	96	110	132	145	157	171	
Diagonal Lumber Sheathing	0.30	429	540	686	913				
Plaster on Wood Lath	0.45	440	538	414	391				
Plywood Panel Siding	0.15	354	420	496	549	565	505	449	
Gypsum Wallboard	0.30	202	213	204	185	172	151	145	107
Plaster on Gypsum Lath	0.45	402	347	304					
Wood Structural Panel 8d@6	0.15	521	621	732	812	836	745	686	
Wood Structural Panel 8d@4	0.15	513	684	826	943	1018	1080	1112	798
Wood Structural Panel 8d@3	0.15	1072	1195	1318	1482	1612	1664	1686	1638
Wood structural Panel 10d@6	0.15	548	767	946	1023	1038	1055	1065	
Wood Structural Panel 10d@4	0.15	707	990	1275	1420	1466	1496	1496	1185
Wood Structural Panel 10d@2	0.15	1120	1568	1999	2248	2405	2512	2512	2231

D.5 Adjustment Factor for Combinations of Bracing Materials

Where more than one material with differing load-drift behavior is applied to the same section of bracing wall, the load-deflection behavior for the combination of materials must be determined. This section presents the available data used in Section 4.4 of the *Guidelines*.

At time of writing, only limited research data were available in which bracing materials were tested individually and then in combination.

Testing by Pardoen et al. (2003), presented earlier, had the evaluation of individual and combined materials as one of its goals. From this testing, individual test walls were evaluated with wood structural panel sheathing, gypsum wall board, and stucco. In addition, a wall was tested with all three materials applied. The results of this testing are shown in Table D-15 and Figure D-14. The figure clearly illustrates that even when individual wall

Table D-15 Data for Combined Materials

Sheathing Shear Capacities (lb)										
Material / Data Source / Type	Drift Ratio (%)									
	0	0.5	0.7	1	1.5	2	2.5	3	4	5
Combined test - Pardoen et al. (2003) Test 13A (a)	0	10880	12910	14250	15160	14470	11460	8360	7170	
OSB - Pardoen et al. (2003) Test 6A	0	8220	9080	10060	10780	11190	8980	7050	6520	
Stucco - Pardoen et al. (2003) Test 17A	0	6970	7230	7230	7580	8110	7690	7230	6460	
Gypsum wallboard - Pardoen et al. (2003) Test 19A	0	1500	1470	1330	1220	1130	1140	1150	990	
Summed - Pardoen et al. (2003) Test 6A+17A+19A	0	16690	17780	18620	19580	20430	17810	15430	13970	
Alt Stucco -	0	4930	4930	3610						
Combined with Alt Stucco	0	14650	15480	15000	12000	12320	10120	8200	7510	
Wood plus 50% other		12455	13430	14340	15180	15810	13395	11240	10245	
Other plus 50% wood		12580	13240	13590	14190	14835	13320	11905	10710	

capacities are summed for each drift ratio, the sum implied by the individual test is greater than justified by the test with all three materials. Also shown in Figure D-14 are two recommended approaches for summing materials. One adds the full capacity of the materials that peak at low drift ratios (stucco and gypsum wallboard) to half of the capacity of the wood structural panel wall that peaks at higher drift ratios. The second adds half of the low drift ratio materials to the full capacity of the wood structural panel walls. Both appear to give a reasonable prediction of the test with combined materials.

A second data source to be considered for combining materials comes from testing by Forintek (Karacabeyli, 1997). Average peak capacities are reported for shear wall testing with oriented strand board (OSB) alone (2.21 k), gypsum wallboard only (0.84 k) and the two tested in combination (2.77 k).

This would support adding all of the OSB peak capacity to half of the gypsum wallboard capacity.

A third data source is testing is Toothman (2003) who performed cyclic testing of 4-ft-by-8-ft walls with gypsum wallboard alone, OSB alone, and gypsum wallboard plus OSB combined. Data indicate that the peak capacity of the combined gypsum wallboard and OSB is equal to 100% of the OSB peak capacity plus approximately 60% of the gypsum wallboard peak capacity.

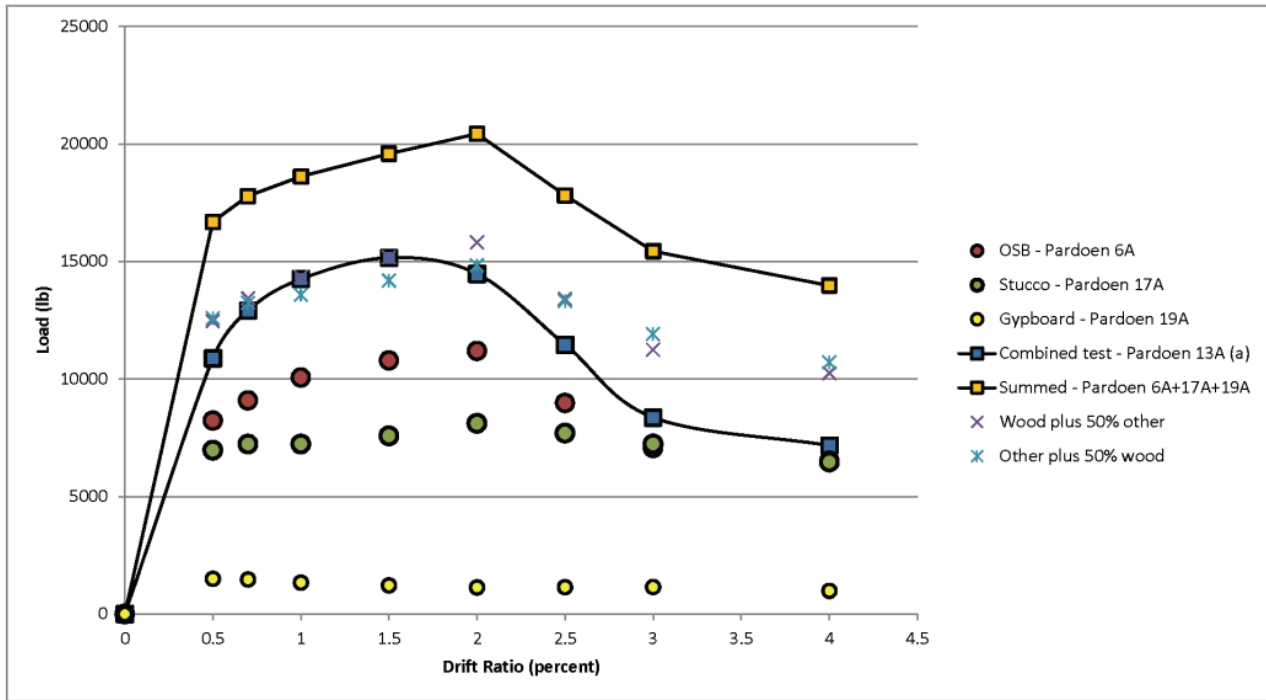

Figure D-14 Plotted load-deflection curves for combined materials.

These are only three points of data in a wide range of potential material combinations. While they have provided a general direction for the *Guidelines* document, much more research in this area is needed to properly characterize building behavior.

D.6 Adjustment Factor for Openings in the Wall Line

This section presents background information on the adjustment factor for openings in wall lines, presented in Section 4.5.2 of the *Guidelines*.

This adjustment has its basis in research used for the perforated shear-wall design methodology, currently included in the American Forest and Paper Association, *Special Design Provisions for Wind and Seismic* (AF&PA SDPWS, 2008), as well as other publications. Perforated shear walls typically have overturning restraint only at the extreme ends of the wall line, and use reduction factors to recognize the lower strength and stiffness inherent in the wall as a result of door and window openings. References for the perforated shear wall method include Sugiyama, 1981; Dolan and Johnson, 1997a, 1997b; and APA, 2005.

The use of this concept in Section 4.5.2 has several important distinctions from the SDPWS rules of application. First, the formula for the adjustment factor is applied to the out-to-out length of the wall line, L_w , whereas the perforated shear wall method uses the sum of full-height segments. The

alternate formulation using L_w is derived from research by Johnson (1997). This formulation was incorporated into the *Guidelines* based on the conclusions in the Johnson report that the SDPWS formulations of the adjustment factor were conservative. For purposes of the *Guidelines*, the intent is to use the most precise formulation possible. The second distinction is that, for purposes of the *Guidelines*, it is intended that the adjustment factor for overturning, in accordance with Section 4.5.3, be applied in addition to the adjustment factor for openings.

D.7 Adjustment Factor for Overturning

This section presents background on the adjustment factor for overturning, presented in Section 4.5.3 of the *Guidelines*. The wall component testing data used to develop Table 4-1 load-drift curves included sufficient overturning restraint to develop the shear capacity of the wall bracing. In actual building configurations, adequate overturning restraint may not always be available.

Section 4.5.3.1 presents a simplified approach to the adjustment for overturning restraint based on a detailed analytical study of a multi-story wood-frame building that is further discussed in Appendix E. The intent of the model was to demonstrate that deformation and loading of the bracing walls that are required to mobilize dead load resistance can occur without significant loss of strength to the bracing elements. The factors tabulated in Table 4-2 are an indication of what strength loss is thought to occur as dead load resistance is mobilized.

Section 4.5.3.2 presents a calculated method for determining the overturning adjustment factor. It is intended that this method follow typical design practice in quantifying resisting moments due to uniform and concentrated dead loads. The overturning moment to be used is based on the peak capacity of the wall line, including use of the procedures for combining load-drift curves for sheathing materials and the adjustment factors for openings.

The calculated method is permitted to be used considering only the overturning and resisting moments from the single story. This assumes that overturning and resisting moments are balanced in the story above. This is particularly helpful for first-story walls that do not stack with walls in the stories above. The calculated method is also permitted to be used considering the overturning and resisting moments from the story under consideration and stories above, as is current design practice. This is more realistic for exterior walls that stack with stories above and therefore have a good deal of inherent continuity.

Equation 4-5 calculates the adjustment factor, Q_{ot} , considering the overturning and resisting moments. The equation defaults to 0.4 when the resisting moment is zero, based on the judgment of the *Guidelines*' writers.

Although the detailed analytical overturning study included modeling of the first story and factors were derived for the first story, the *Guidelines* require that the first story use the Section 4.5.3.2 calculated method of determining the overturning factor. A number of factors affected this decision including:

- The first-story capacity is critical to the behavior of weak-story buildings. This one detailed analytical study does not provide a level of comfort adequate to set aside current design practice for overturning restraint of these walls.
- Two of the case study buildings documented in *Woodframe Project Case Studies* (Schierle, 2001) were weak-story buildings constructed circa 1971. Both were proportioned for shear but lacked overturning restraint, and both suffered substantial collapse. Although the lack of overturning restraint was not the only possible source of weakness, these case studies point to needing a better understanding prior to allowing the use of Table 4-2 adjustment factors in the first story.

D.8 Drift Adjustment for First-Story Wall-Line Height

Section 4.5.4 specifies an adjustment of the drift ratios used to define the load-drift curve. It is applied to first-story wall lines with a height of less than eight feet, and recognizes that the drift at peak capacity is reduced for a shorter wall height. Based on cripple wall testing from the CUREE project (Chai et al., 2002), however, the reduction in drift at peak capacity is less severe than a linear reduction based on wall height. Cripple walls with a height of two feet (specimens 4 and 5 in the Chai et al. study) and sheathed with wood structural panel and stucco were seen to have a drift at peak capacity of approximately 1". Similar cripple walls with a height of four feet (specimens 7 and 8) were seen to have a drift at peak capacity of 1½ to 2". These can be compared to drifts at peak capacity of 2½ to 3" for 8-ft walls. A reduction based on the ratio of heights to the 0.7 power is used to approximate this behavior.

In order for wall lines of different heights to be combined, a common set of drift ratios will need to be used. Straight-line interpolation is recommended for adjusting back to the typical drift ratios.

D.9 Descriptions of Damage versus Drift

In order to relate observed damage to drift demand, it is desirable to have descriptions of damage to bracing materials as a function of the story drift imposed during testing. This section summarizes available information from three testing programs. The reader is cautioned that these must be considered general indications of damage only, as it is anticipated that damage observed can vary widely.

Arnold, Uang and Filiatrault (2003)

Two configurations of walls were tested to failure. Wall 1 was 8 ft by 16 ft with two window openings. Wall 2 was 8 ft by 16 ft with one door and one window opening. Displacement controlled testing using the CUREE protocol was used. Each wall was sheathed with stucco on one side and gypsum wallboard on the other. The report provides written descriptions of visual damage at drift ratios of 0.2%, 0.5%, 0.7% and “failure” (defined as reduction to below 80% of peak capacity). The report also provides crack maps at these drift intervals, and numerous photos of damage examples. Note that these panels reached peak capacity at about 1% drift and “failure” between 1.7% and 2%. These drifts are higher than described earlier in this report for the individual materials tested separately. While this complicates interpretation, it is the best available information. It is suggested that the descriptions of damage be considered applicable at the stated drifts rather than conversion of drifts being made.

Figures D-15 through D-30 are excerpted from the Arnold et al. (2003) report, including paraphrasing of damage descriptions. See the full report for more detail. Crack widths indicated are at zero applied load, following loading to the noted drift.

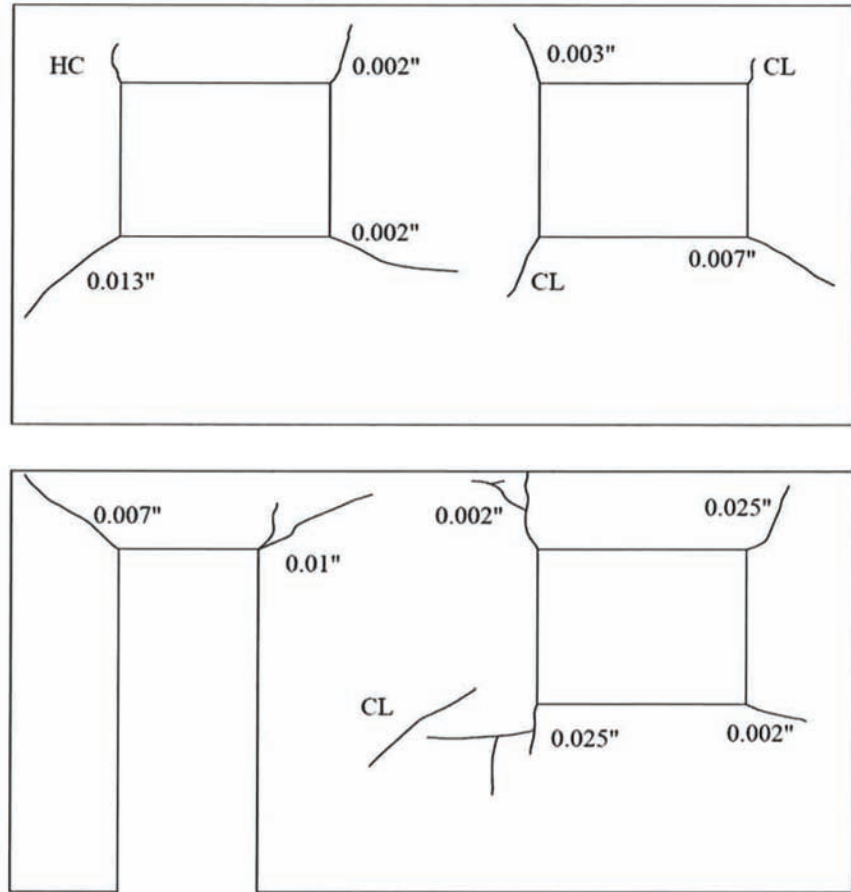

Figure D-15 Crack maps for stucco sheathing at 0.2% drift for (top) Wall 1 and (bottom) Wall 2. Minor cracking of finish started at opening corners and propagated diagonally. No deterioration of behavior occurred during trailing cycles. CL indicates a crack that closed during unloading. HC denotes hairline crack of width less than 0.002 inches (from Arnold, Uang and Filiatrault, 2003).

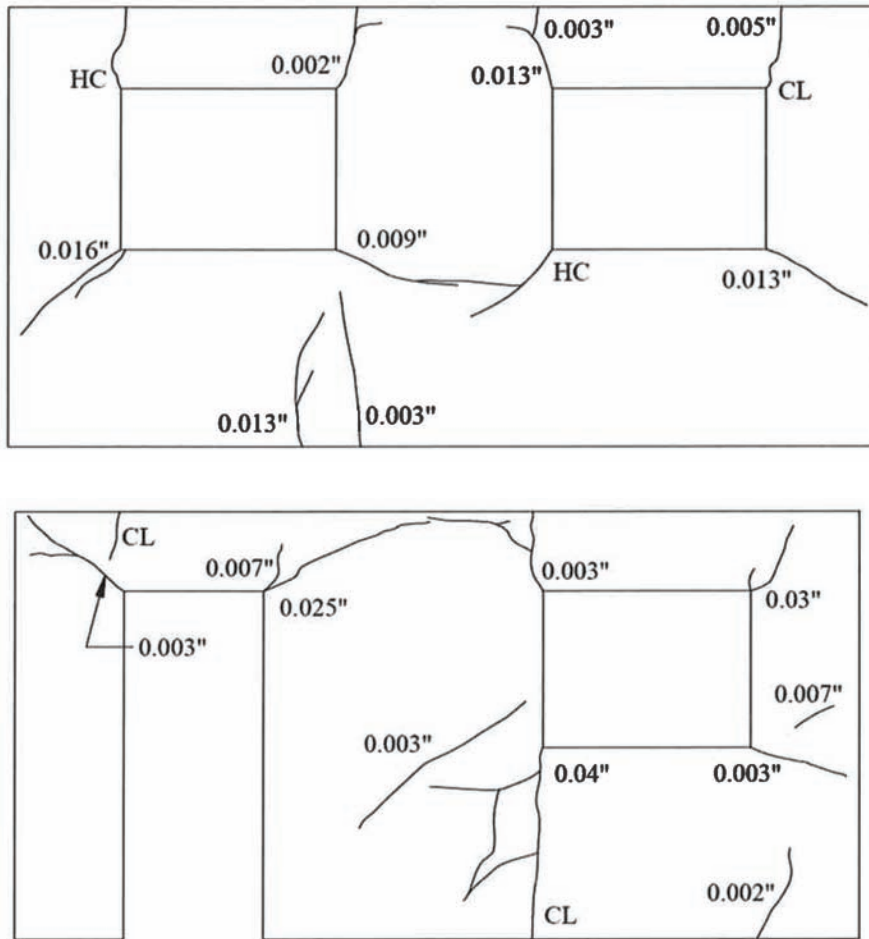

Figure D-16 Crack maps for stucco sheathing at 0.4% drift for (top) Wall 1 and (bottom) Wall 2. Stucco cracks from 0.2% drift increased in length and width. New cracks branched from the existing cracks and at some locations cracks propagated to the stucco boundaries. CL indicates a crack that closed during unloading. HC denotes hairline crack of width less than 0.002 inches (from Arnold, Uang and Filiatrault, 2003).

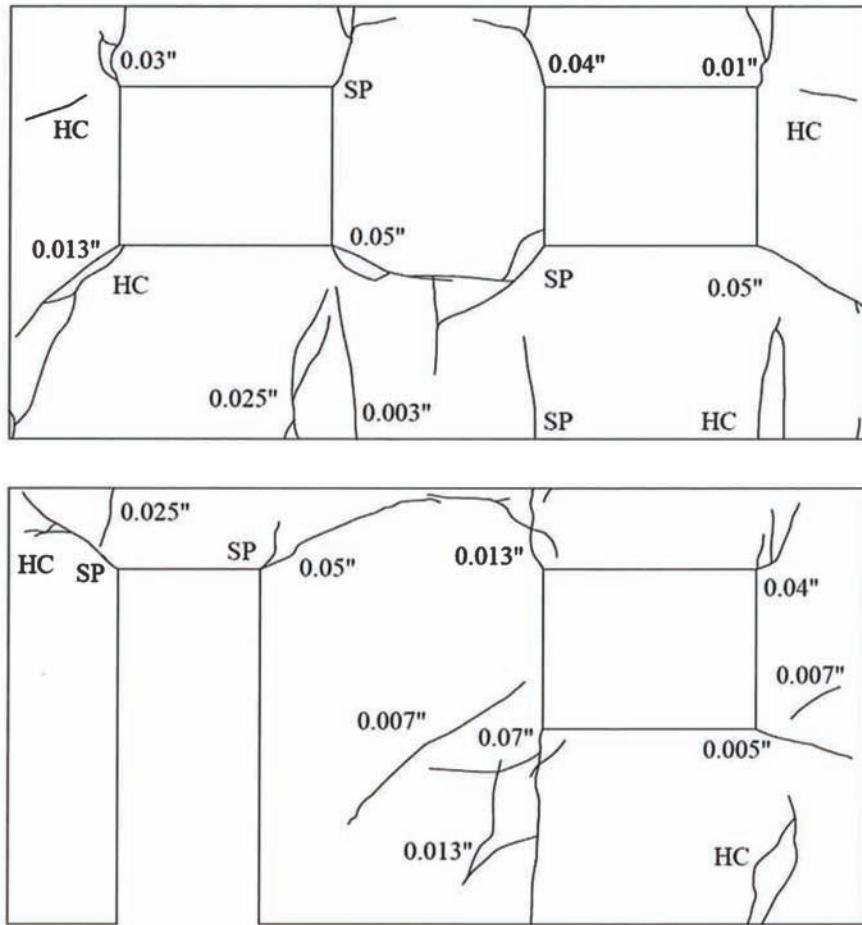

Figure D-17 Crack maps for stucco sheathing at 0.7% drift for (top) Wall 1 and (bottom) Wall 2. Most cracks that originated at opening corners propagated to the stucco boundaries. More cracks initiated at the stucco boundaries and at wall pier edges. All existing cracks increased in length and width. HC denotes hairline crack of width less than 0.002 inches. SP indicates locations where the stucco finish coat spalled, such that it was not possible to measure a crack width (from Arnold, Uang and Filiatrault, 2003).

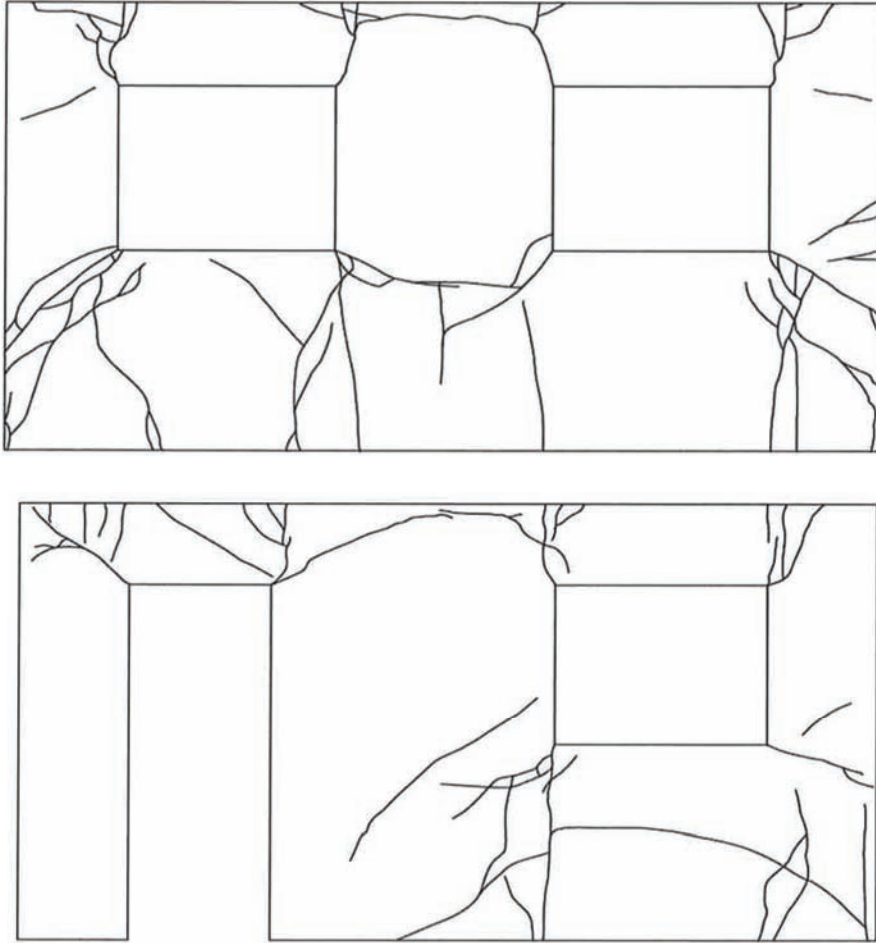

Figure D-18 Crack maps for stucco sheathing at failure for (top) Wall 1 and (bottom) Wall 2. In addition to stucco cracking shown, damage included spalling of the stucco, rotation of j-molds at the wall top, and twisted studs at wall ends (from Arnold, Uang and Filiatrault, 2003).

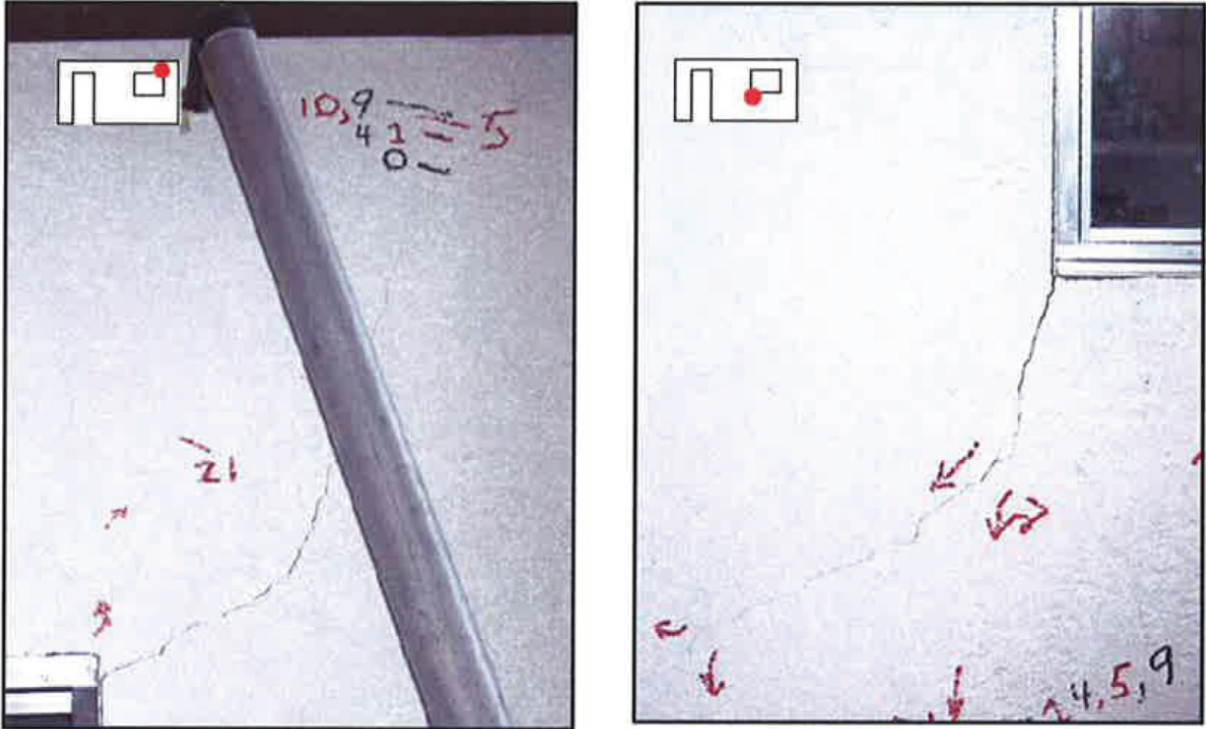
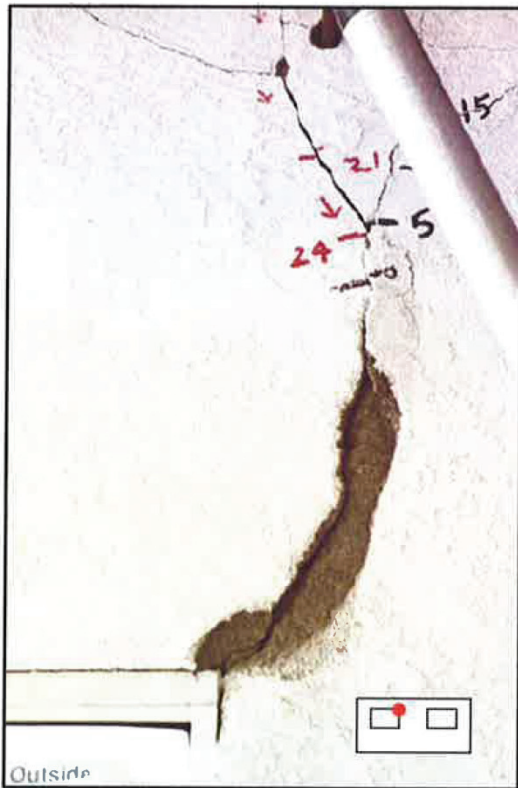

Figure D-19 Photos of characteristic cracking at 0.4% drift. Red dot indicates location of photograph (from Arnold, Uang and Filiatrault, 2003).



(a) Finish Coat Spalling



(b) Finish Coat Spalling

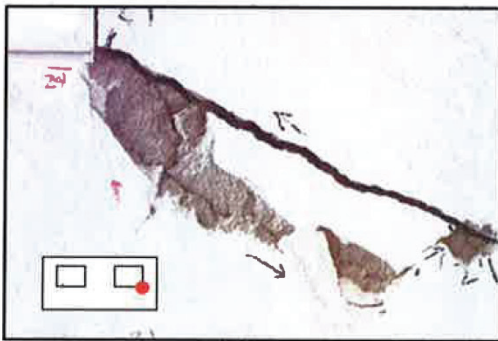

(c) Crumbled Basecoats

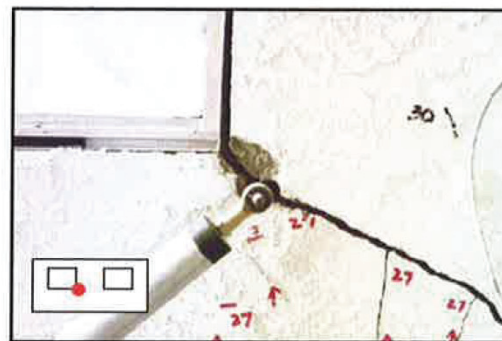

(d) Large Crack Widths

Figure D-20 Photos of characteristic cracking at 1.5% drift (from Arnold, Uang and Filiatrault, 2003).

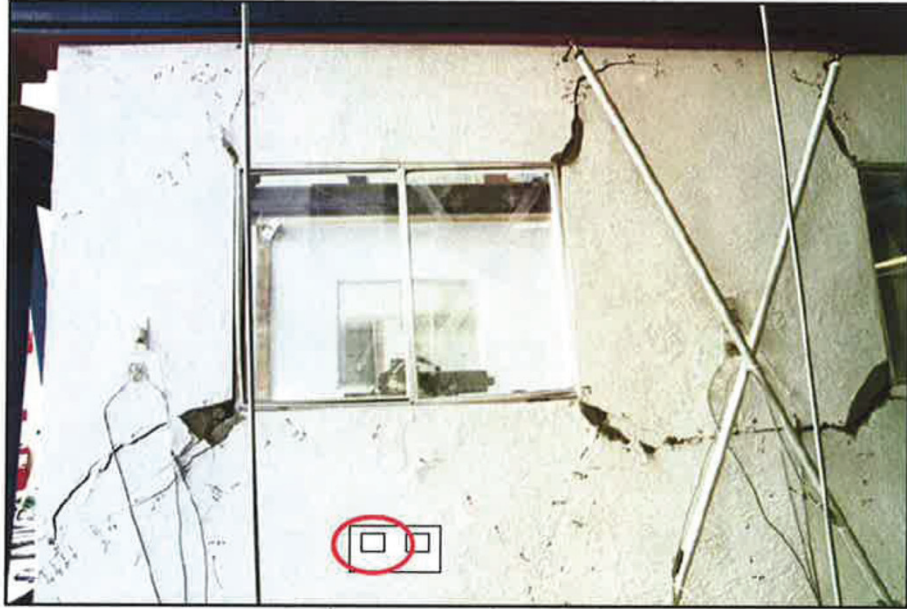

(a) Northern Window

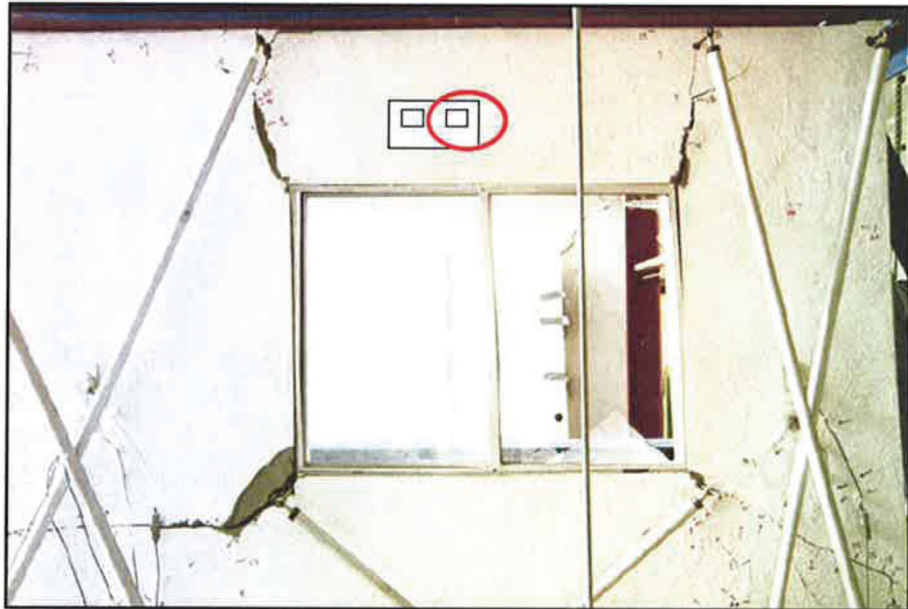

(b) Southern Window

Figure D-21 Photos of characteristic cracking at failure (from Arnold, Uang and Filiatrault, 2003).

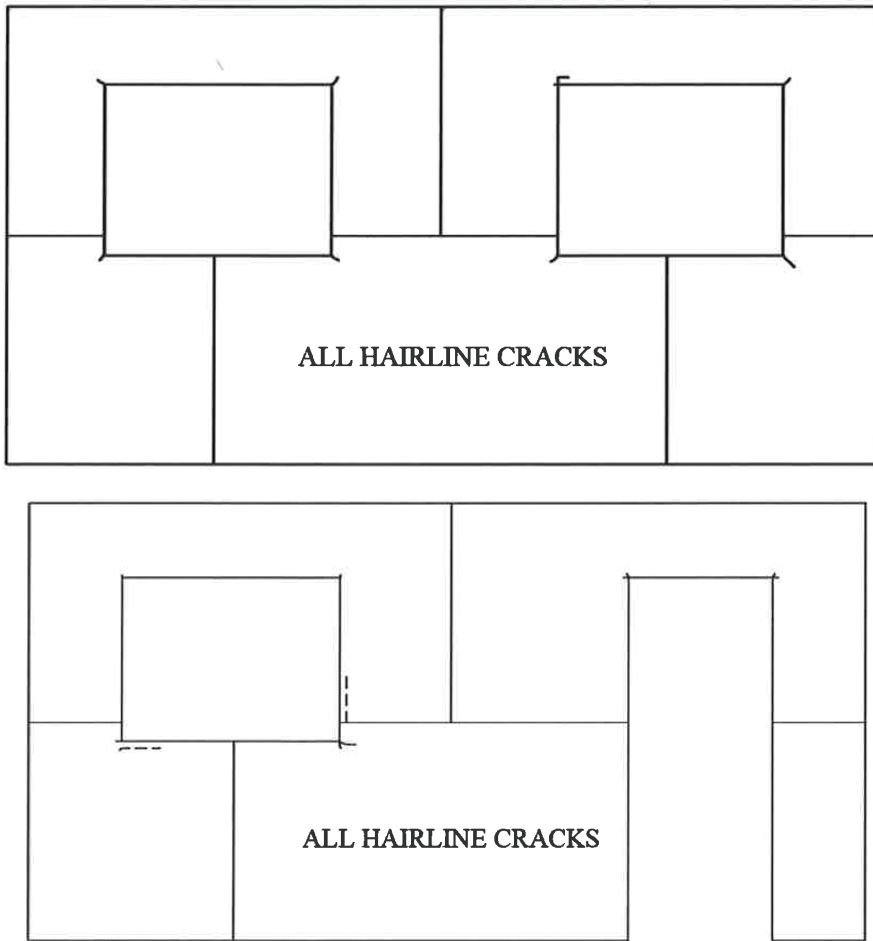

Figure D-22 Crack maps for gypsum wallboard sheathing at 0.2% drift for (top) Wall 1 and (bottom) Wall 2. Small hairline cracks formed near corners of the windows and along the edges of corner beads (from Arnold, Uang and Filiatrault, 2003).

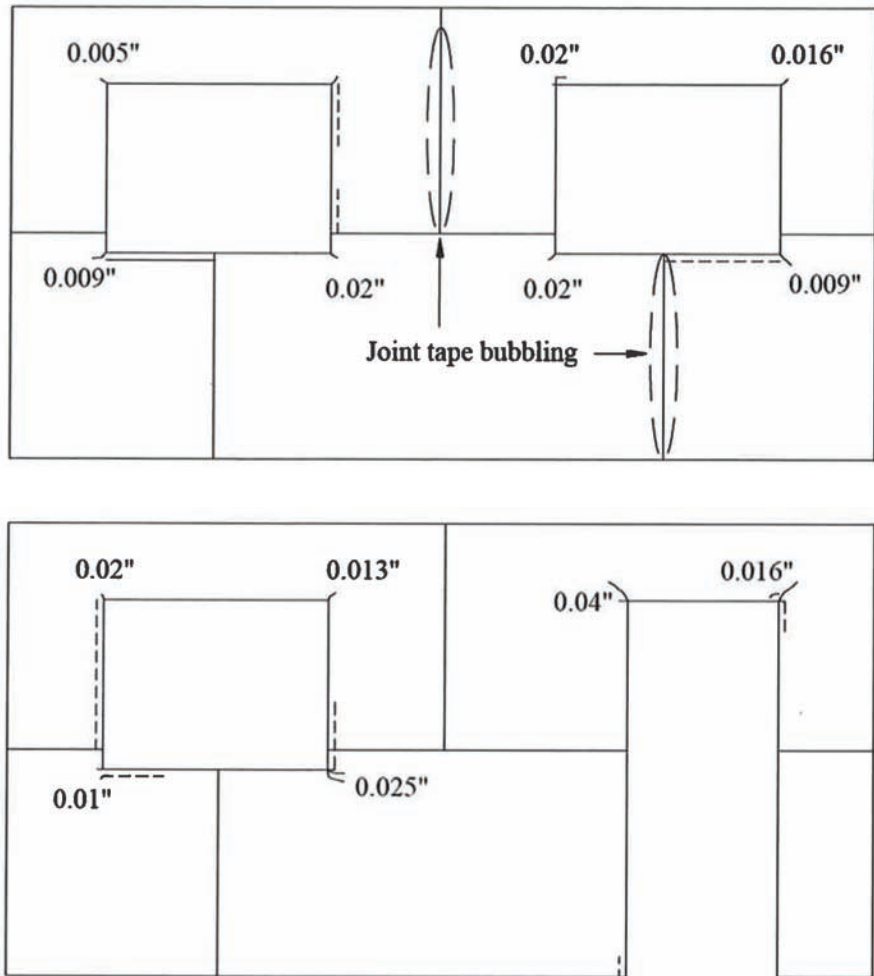

Figure D-23 Crack maps for gypsum wallboard sheathing at 0.4% drift for (top) Wall 1 and (bottom) Wall 2. Cracking at corners and edges of windows increased. Joint tape bubbling and nail popping started to occur (from Arnold, Uang and Filiatrault, 2003).

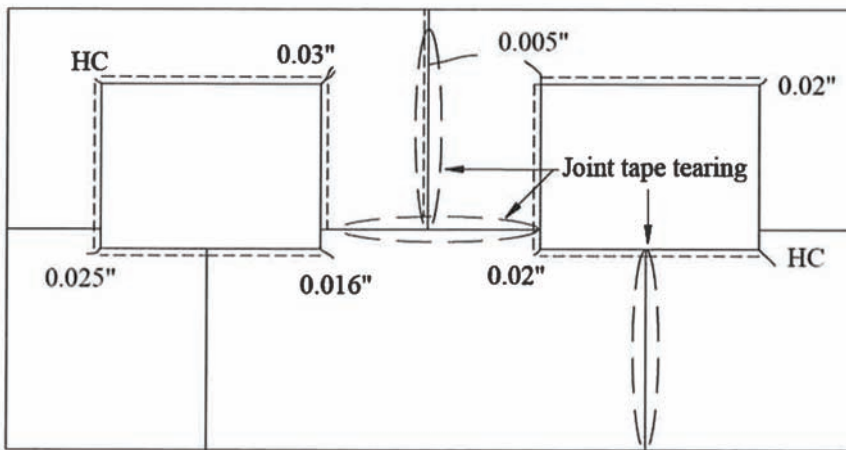
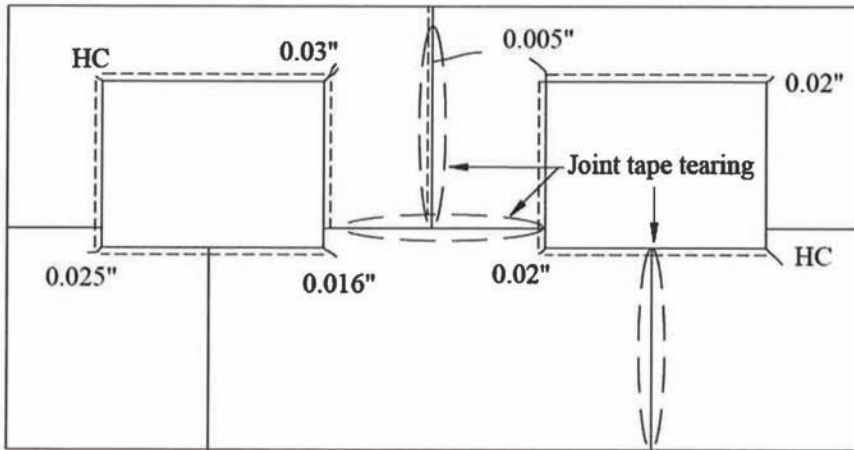

Figure D-24 Crack maps for gypsum wallboard sheathing at 0.7% drift for (top) Wall 1 and (bottom) Wall 2. Crack width and length increased. Nail pops increased. Crushing of the gypsum core occurred at window corners in compression. Tearing of the joint tape occurred, leading to wall board panels rotating individually (from Arnold, Uang and Filiatrault, 2003).

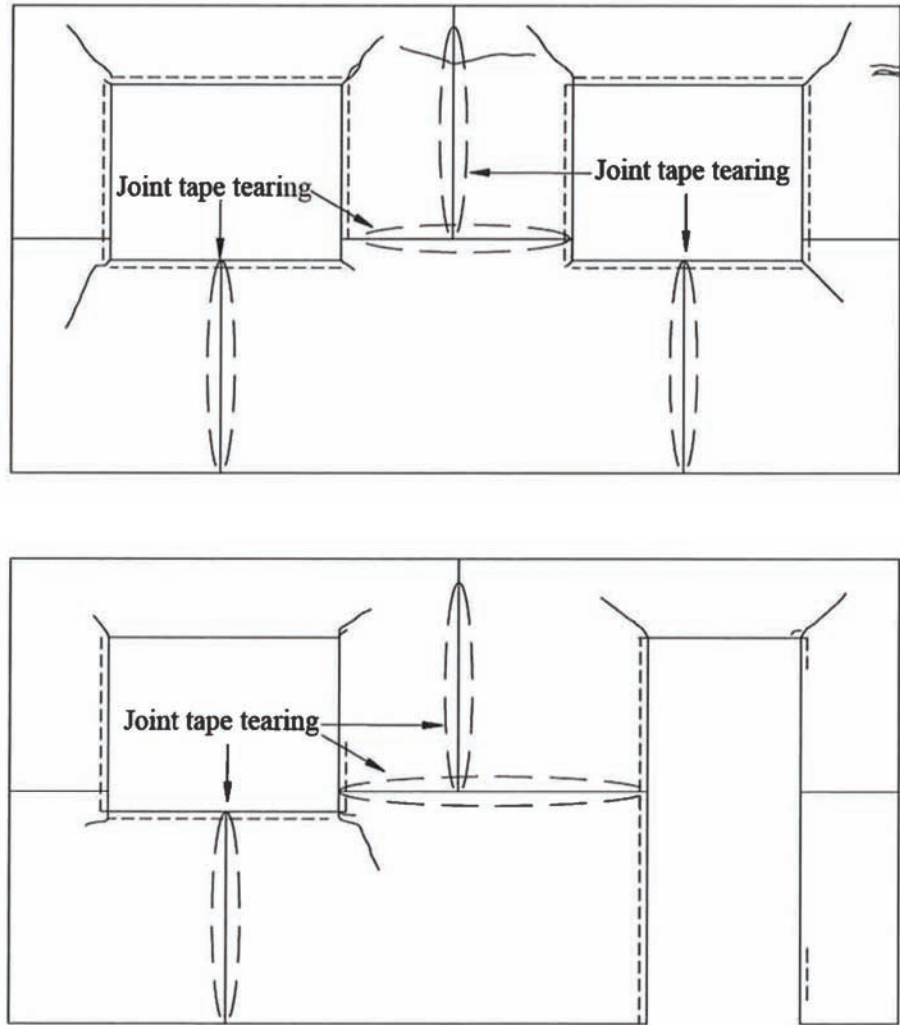
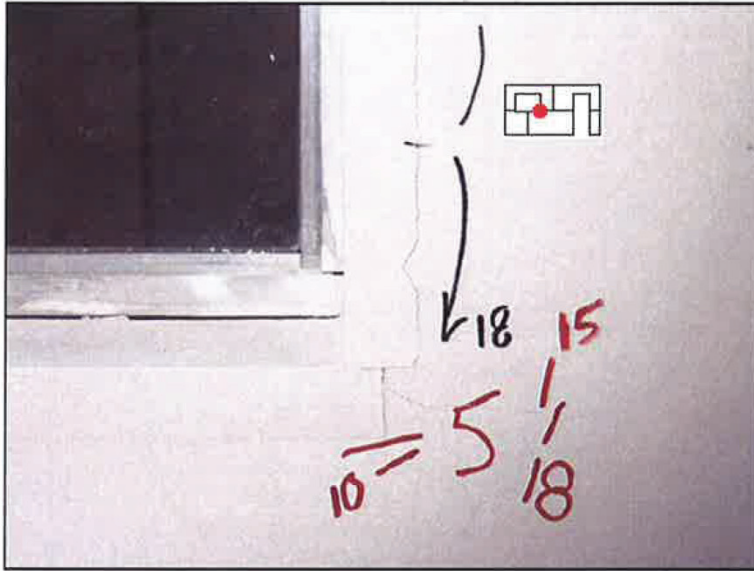
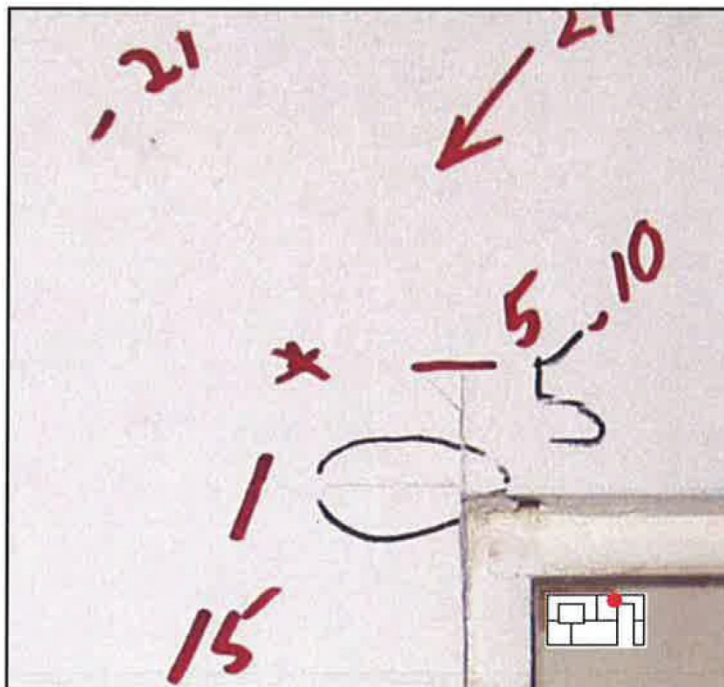

Figure D-25 Crack maps for gypsum wallboard sheathing at failure for (top) Wall 1 and (bottom) Wall 2. Most of the wallboard joints were significantly damaged, and wallboard piers rotated relative to each other. Large crack widths and lengths were observed at all opening corners. “Ridging” at the wallboard joints was observed following large displacements. Nail popping became more obvious. Gypsum wallboard movement relative to the framing was obvious at the door opening (from Arnold, Uang and Filiatrault, 2003).



(a)



(b)

Figure D-26 Photos of characteristic cracking at 0.4% drift (from Arnold, Uang and Filiatrault, 2003).

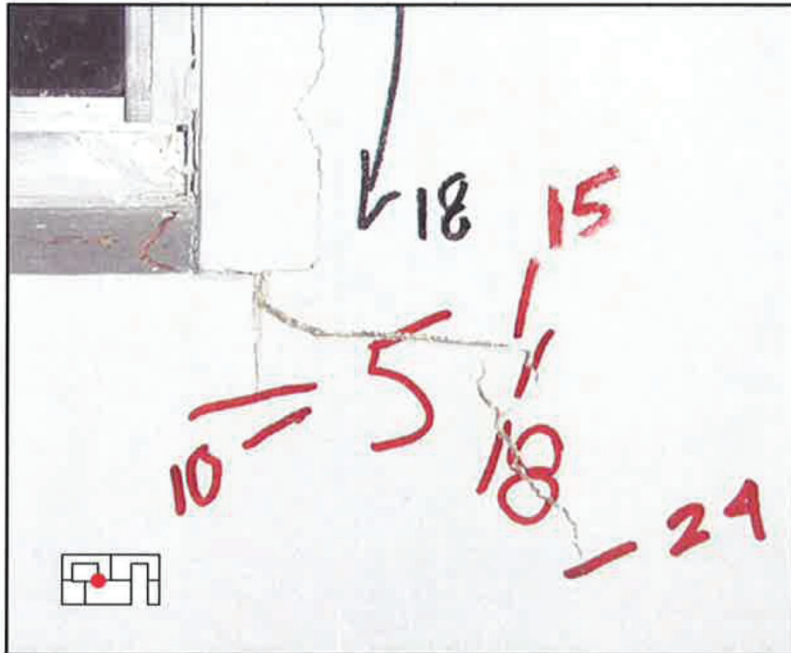

(a)

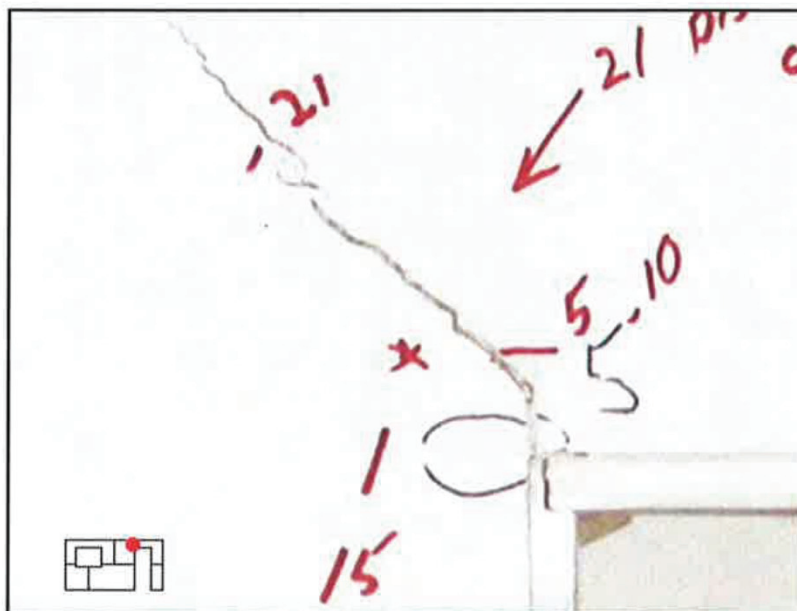

(b)

Figure D-27 Photos of characteristic cracking at 0.7% drift (from Arnold, Uang and Filiatrault, 2003).



(a) Northern Window

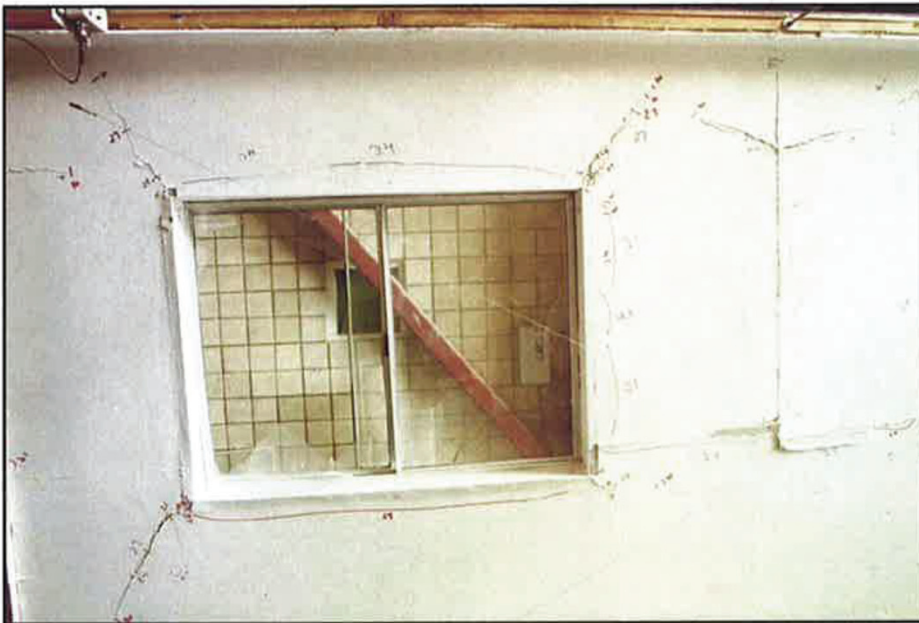

(b) Southern Window

Figure D-28 Photos of characteristic cracking at 1.5% drift (from Arnold, Uang and Filiatrault, 2003).

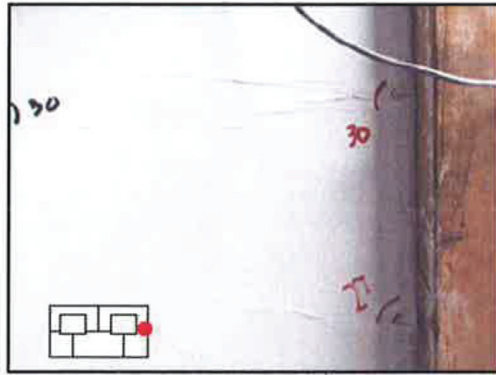

(a) Wallboard Ridging at Panel Boundary

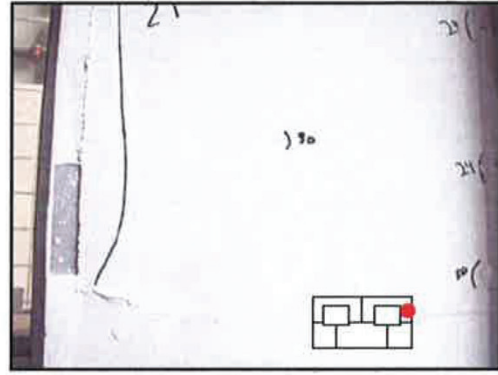

(b) Corner Bead Finish Flaking

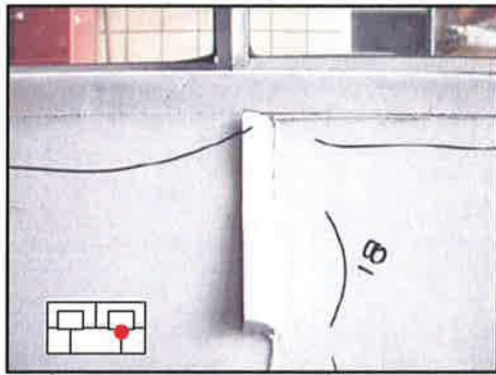

(c) Joint Tape Bulging

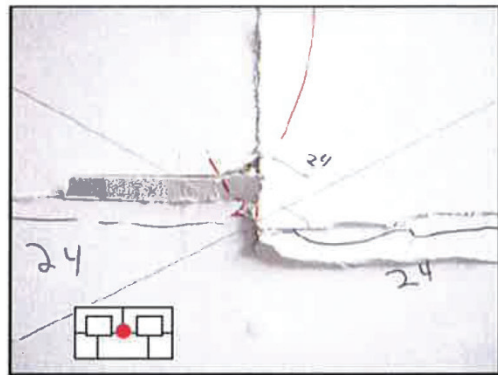

(d) Joint Tape Tearing

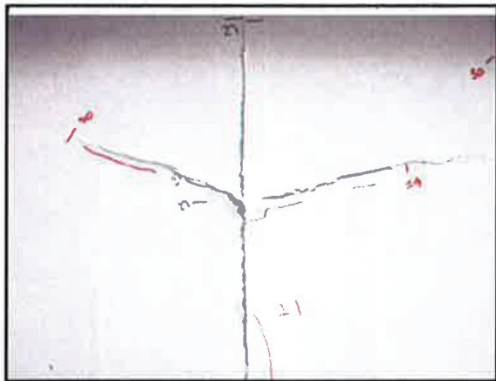

(e) Wallboard Cracking/Joint Tape Tearing

Figure D-29 Detailed photos of characteristic wall cracking at 1.5% drift (from Arnold, Uang and Filiatrault, 2003).

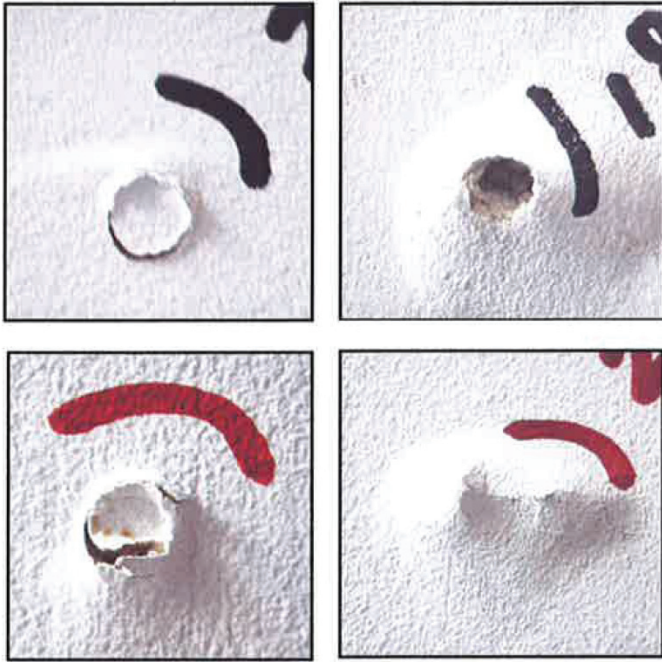
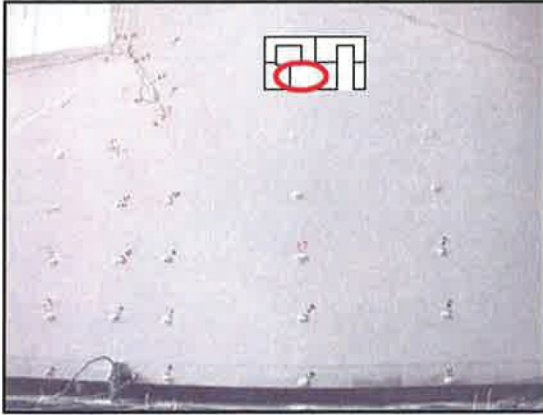

Figure D-30 Photos of characteristic cracking at 1.5% drift showing wallboard fastener popping (from Arnold, Uang and Filiatrault, 2003).

Table D-16 Descriptions of Damage States and Drifts (from McMullin and Merrick, 2002).

Damage State	Wall Drift (inches) ¹					
	Test 6 Front	Test 6 Back	Test 7 Front	Test 7 Back	Test 11 Front	Test 11 Back
Cracking of Paint over Fastener Head	0.34 034 (-25)	0.18 0.24 (-23)	0.250 0.250 (+25)	0.250 0.250 (+25)	0.524 0.524 (+32)	0.472 0.472 (+29)
Cracking of Wallboard at Wall Penetration	0.24 0.24 (+21)	0.24 0.24 (+21)	0.090 0.120 (+17)	0.090 0.120 (+17)	0.121 0.121 (-14)	0.258 0.258 (+21)
Crushing of Wallboard at Perimeter	2.00 2.00 (+41)	1.25 1.25 (+38)	0.777 0.777 (+32)	NR	2.376 2.376 (+41)	N/A
Cracking of Vertical Butt Joint	N/A	0.75 0.75 (+32)	0.301 0.419 (+27)	0.301 0.419 (+27)	0.357 0.472 (+31)	0.268 0.394 (-28)
Cracking of Horizontal Wall Joint	N/A	N/A	N/A	N/A	0.660 0.660 (-32)	N/A
Cracking of Vertical out-of-Plane Joint	0.25 0.36 (+29)	0.25 0.25 (-25)	0.301 0.419 (+27)	0.359 0.359 (-25)	0.785 0.785 (+32)	N/A
Local Buckling of Panel at Wall Penetration	0.75 0.75 (-32)	Note A	0.419 0.419 (+25)	0.359 0.359 (-25)	0.130 0.130 (+14)	0.258 0.258 (+21)
Global Buckling of Panel	1.94 1.94 (+41)	4.17 4.17 (+50)	N/A	1.710 1.710 (+38)	N/A	N/A

Notes:

1: First row of data in each data set is the drift at which the damage threshold was observed; second row of data is the maximum drift in the same direction that the wall had sustained when the damage threshold was identified; the third row of data is the loading excursion number when the damage threshold was observed.

A: Local buckling was not seen as a distinct damage state; instead, all re-entrant corners at wall openings showed initial cracking at low levels of drift.

N/A: not applicable.

NR: not recorded (assumed meaning, as meaning not provided in reference)

McMullin and Merrick (2002)

A series of damage states and associated drifts for the cyclic tests conducted by McMullin and Merrick (2002), as documented in Table 10 of their report, is provided in Table D-16. The three test specimens described were gypsum wallboard with screws at 16 inches on center, tested cyclically. The walls reached peak capacity between 0.7% and 1% drift. Note that between test walls there was significant variability in the drift at which damage states occurred.

Forest Products Laboratory (1956)

Figure D-31 provides illustrations of the damage condition of two tested walls with plaster and wood lath. The photos are assumed to have been taken



Figure D-31 Photos of characteristic cracking at completion of Forest Products Lab testing (from Trayer, 1956).

at the conclusion of testing. Based on limited notes provided in the test report, it is estimated that cracking on the upper panel initiated at approximately 0.5% drift, and the photo was taken after testing to 0.7% drift. Similarly it is estimated for the bottom panel that cracking initiated at 0.1% drift and the photo was taken after testing to 0.9% drift. These panels were loaded monotonically, and post-peak capacity behavior was not investigated.

Discussion of Research Results

Based on the combination of the descriptions and photos provided by Merrick and McMullin (2002) and Arnold, Uang and Filiatrault (2003), for gypsum wallboard, it appears that breaking down of the taped joints, resulting in panels being able to rotate individually, are key behaviors relating to declining strength of gypsum wallboard sheathing. Regardless of this performance similarity, photos appear to indicate that visible damage in the Arnold, Uang and Filiatrault (2003) testing was primarily at taped joints and window and door openings, while prominent visible damage in the McMullin and Merrick (2002) testing was cracking initiating at opening corners.

D.10 Recommended Future Research

Efforts to characterize upper-story strength and stiffness for these *Guidelines* pointed out a number of areas in which additional information would help provide more reliable predictions, allowing better optimization of retrofit designs. The steps selected for characterization for these *Guidelines* involved identifying material load-deflection behavior, combining material behavior, establishing wall lines for analysis, adjusting wall line capacity for wall openings and overturning restraint, and combining wall lines to describe story behavior. At each step, limitations were encountered due to lack of substantial relevant data and lack of quantified full building behavior to provide validation of modeling. Future research is needed to better quantify the characteristics of upper-story bracing, whether using this same step by step process or a more integrated approach. Adequate characterization of the upper stories is critical to providing the widest range of optimized retrofit designs and better understanding of the performance of the retrofitted building.

As a minimum the following are recommended as high priority for future research:

- Component testing with archaic materials to better establish the range of anticipated material behavior. Significant attention is needed to establishing realistic boundary conditions for the testing.
- Evaluation and incorporation of data from in-plane testing of brick veneer.
- Component testing for individual materials and differing materials used in combination, to better establish how common combinations of materials perform.
- Analysis and data sets for validation of models converting individual wall pier behaviors to full building behavior, accounting for openings and overturning restraint.
- Additional testing correlating visual damage to peak sustained drifts and anticipated load-deflection properties.

As additional testing is conducted, the following are important:

- Use of a consistent loading protocol or additional data to allow conversion between protocols.
- Testing to drift levels that result in collapse mechanisms.
- Realistic bracing material boundary conditions.
- Attention to loading beam stiffness and interaction with components being tested.

Appendix E

Detailed Analytical Background

E.1 Purpose

The purpose of this appendix is to provide a link between the recommendations in Chapters 3 through 7 and the underlying analytical work.

E.2 General

E.2.1 Overview and Limitations

The main goals of the analysis work done to support the *Guidelines* are as follows:

- Estimate the seismic performance of existing structures with weak-story vulnerabilities;
- Explore the applicability of the first-story retrofit and validate its effectiveness;
- Quantify the first-story retrofit strength that optimizes seismic performance for a stipulated set performance criteria; and
- Take into account the effect of torsion.

The focus of the *Guidelines* is wood-framed structures between two and four stories with lateral resistance from stud walls with various sheathing materials. Buildings with varied weak-story vulnerabilities were analyzed.

E.2.2 Building Characterization

The approach to understand the seismic performance of both the existing and retrofitted structures relies on a large breadth of nonlinear response-history analyses performed on simplified building models. There are three main characteristics that vary among the many permutations of model buildings, and each has a corresponding parameter in the *Guidelines*:

- Residual strength, parameterized by the strength degradation ratio, C_D ,
- Base-normalized, upper-story strength, parameterized by A_U ,
- Ratio of first-to-upper-story strength (i.e., weak-story ratio), parameterized by, A_W .

The suite of analyses covers a large range of variations among these three parameters to form a reliable basis for recommendations.

E.2.3 IDA Approach

The *Guidelines* accommodate a range of building configurations and seismic hazards. This is achieved in the analysis by running a range of increasing seismic intensities on every building model permutation. This Incremental Dynamic Analysis (IDA) approach (Vamratsikos and Cornell, 2002) is useful in part because it lends itself to a probabilistic treatment of both seismic hazard and seismic performance. Thus, all results really boil down to probabilistic statements, e.g., the probability of exceeding a particular drift ratio, D , is P for a given seismic hazard, H , which is, in turn, defined by the probability of that hazard being exceeded in Y years.

The results of the IDA can be analyzed by counting the number of response-history records in which a specified set of performance (e.g., interstory drift) criteria were exceeded for each earthquake intensity. The probability of exceedance at each intensity is computed by dividing the number of time-histories causing exceedance by the total number of time-histories. Generally, as the earthquake intensity increases, so does the probability of exceedance, and the data may be fit with good agreement using a log-normal cumulative density function (CDF). The log-normal CDF is defined by two parameters: the mean and the log-normal standard deviation, β . These curves are commonly referred to as *fragility curves*.

Quantifying seismic performance from IDA results requires two input parameters. The general problem statement may be framed as follows: given,

- A building model,
- Seismic performance (e.g., interstory drift) criteria, and
- Seismic intensity (corresponding to some site-specific hazard),

What is the probability that the performance criteria will be exceeded? See Figure E-1.

Conversely the problem statement could flow in the opposite direction: instead of specifying the seismic intensity and asking for the probability of exceedance, one could specify the probability and find the corresponding seismic intensity.

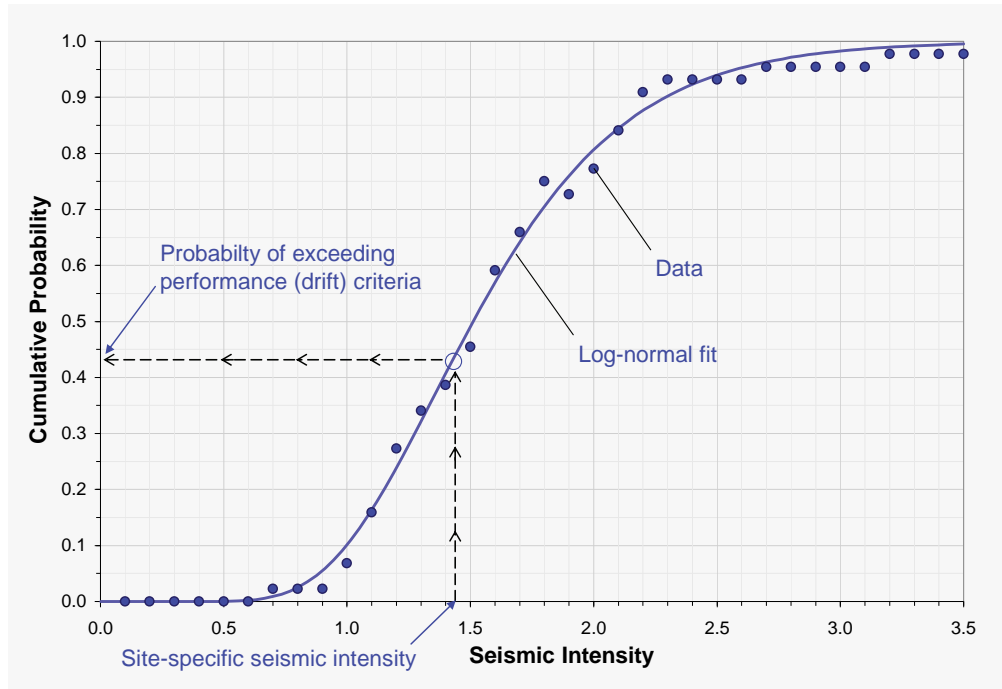

Figure E-1 Illustration of solution flow for Incremental Dynamic Analysis results.

E.2.4 Material Characterization

The *Guidelines* document load-drift data for sixteen different sheathing material types; about one-quarter of those are archaic sheathing materials: lath and plaster, horizontal and diagonal wood sheathing. Among the other materials commonly used today, several are finish materials not often considered to provide lateral bracing in design of new buildings in areas of high seismicity. It is recognized that all sheathing materials provide lateral bracing strength and stiffness, but quantifying that, especially for archaic materials is not trivial. There are two basic hurdles that the *Guidelines* attempt to overcome:

- Quantifying load-drift behavior of a large set of materials, and
- Addressing the fact that these sheathing materials may be combined into a large number of different assemblies.

In order to provide a more accurate evaluation and a better optimized retrofit, it was deemed appropriate to consider each material and its unique load-drift curve. As a simplification, if one assumes that a story level translates without twisting, then all sheathing materials would react to the movement according to their load-drift (backbone) curves. Extending this idea, the *Guidelines* consider that the load-drift curves for sheathing layers on the same wall may be added with some reduction based on limited test evidence.

Median unit load-drift curves were compiled from available test data and are summarized in detail in Appendix D. Where data was limited, gaps were filled for expected values based on extrapolation and judgment. These materials have been organized for convenience into two general categories: low-displacement capacity (Figure E-2) or relatively high-displacement capacity (Figure E-3). The criterion distinguishing the two material types is the story drift ratio at which the material exhibits no residual strength. The low-displacement capacity (Ld) materials have no residual strength at less than 3% interstory drift, the high-displacement capacity (Hd) materials have residual strength that go beyond 3% to about 4% or 5%.

It should be noted here that, given the limited testing for the low-displacement capacity (Ld) materials, there may be more actual displacement capacity than that considered in these analyses. It is difficult to imagine that a structure with these types of materials would become laterally unstable at a drift ratio of around 2%, corresponding to perhaps 2.5 inches of lateral displacement, despite the loss of strength demonstrated in tests. More testing of these materials is needed to improve expectations for the seismic performance of these structures.

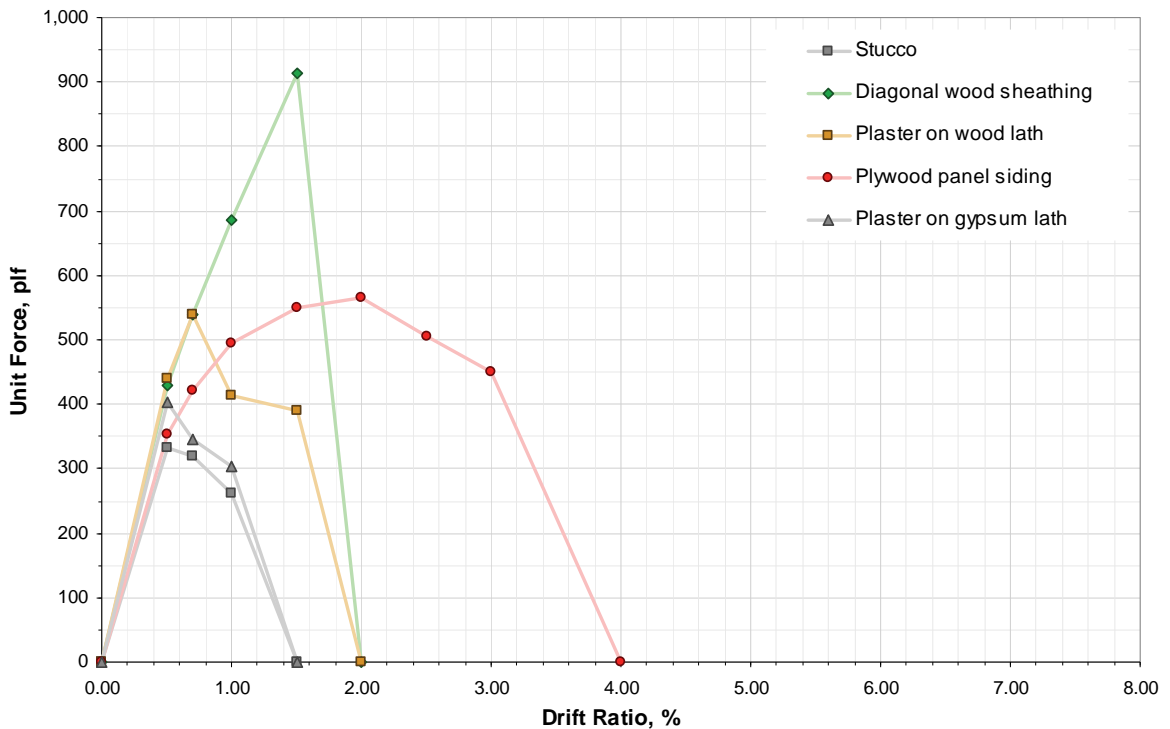

Figure E-2 Unit load-drift curves for materials with low-displacement capacity.

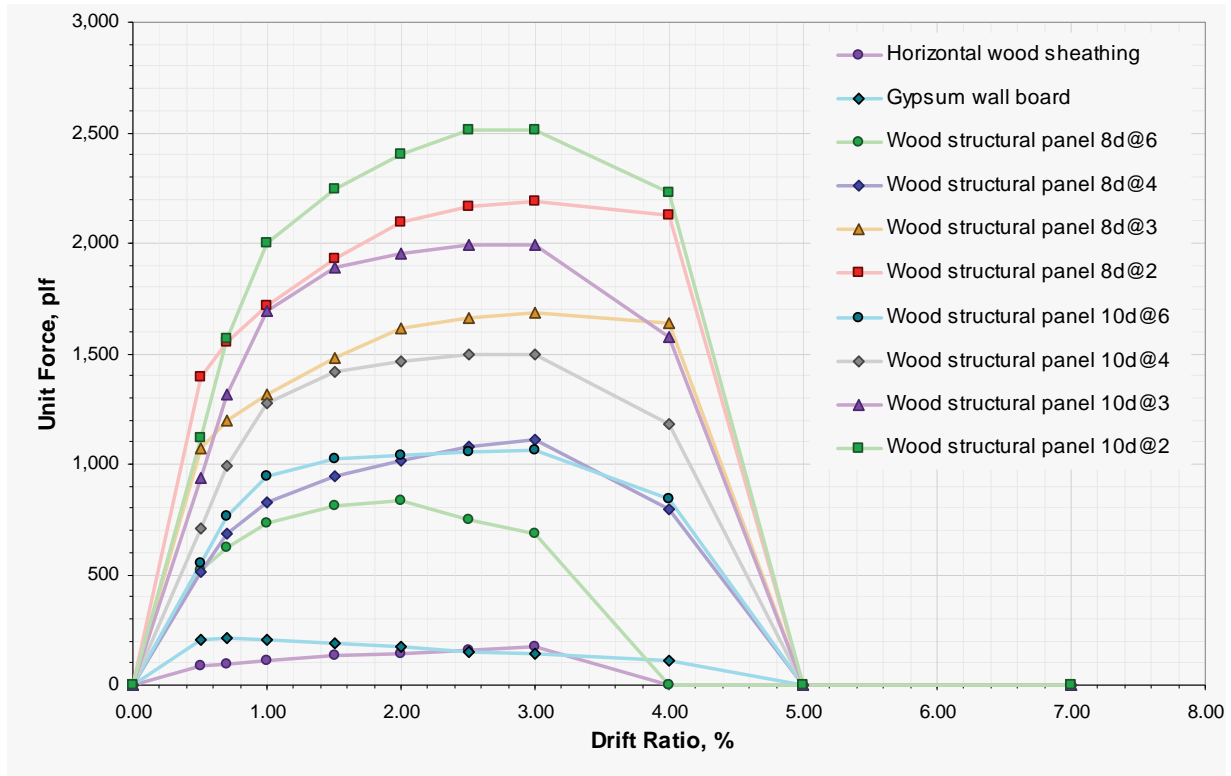

Figure E-3 Unit load-drift curves for materials with high-displacement capacity. Wall panel nailing notation: nail size (e.g., 8d) @ distance between center of nails in inches.

To achieve the analysis objective of modeling a large breadth of buildings, these two categories of materials were simplified into two archetypical forms that were actually modeled (see Figure E-4). These forms, termed low-displacement capacity and high-displacement capacity, are composites of typical assemblies that might be present in the existing buildings of interest. The low-displacement capacity archetype approximately corresponds to a story with a strength degradation ratio, C_D , of 0.0. The high-displacement capacity archetype approximately corresponds to a story with a strength degradation ratio, C_D , of 0.0. Note that low-displacement capacity can be characterized as similar to one layer of stucco and one layer of lath and plaster, and that high-displacement capacity can be characterized as plywood structural panels with edge nailing 8d at 4" on center finished with stucco.

E.2.5 Performance Criteria

To draw useful conclusions from the IDA results, one must specify a set of performance criteria against which a building model will be tested for each response-history, at each intensity increment. One widely used measure of seismic performance is interstory drift ratio. The *Guidelines* optimize performance against collapse by limiting drift on the basis of material

displacement capacity. For this reason, the *Onset of Strength Loss (OSL)* was selected for the drift criteria for each material form. These terms are indicative of the expected state of the wall elements at each level. At *Onset of Strength Loss*, the sheathing material is on the verge of losing capacity to resist lateral forces.

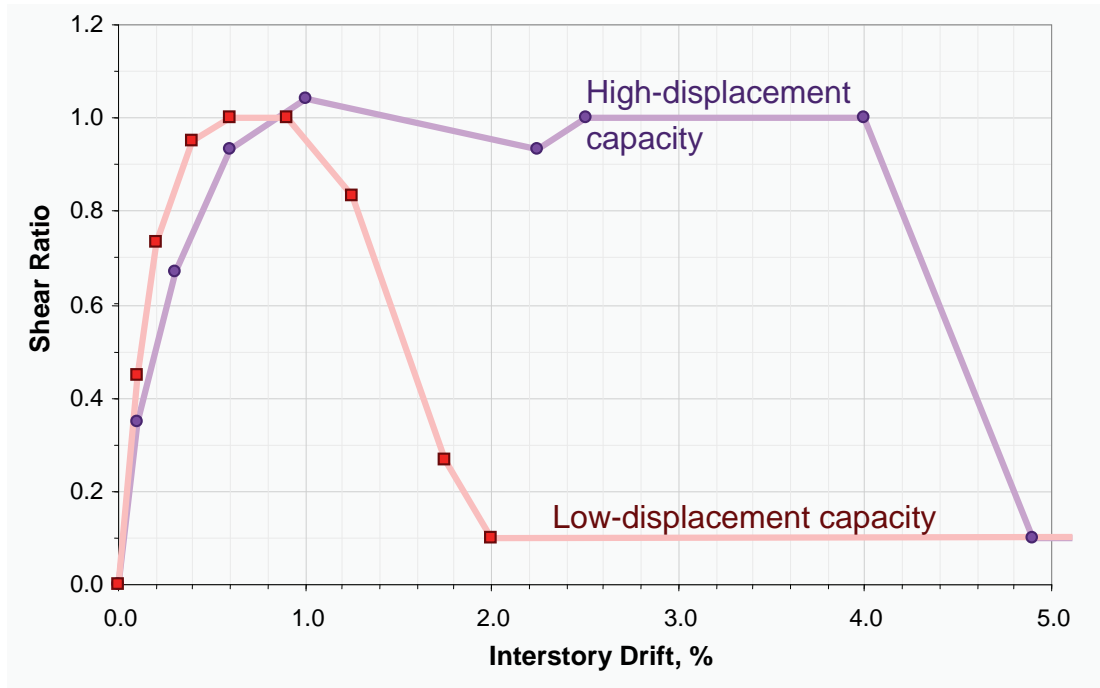

Figure E-4 Load-drift curves for archetypical material forms.

The interstory drift criteria used in quantifying seismic performance are tabulated in Table E-1. For the un-retrofitted archetype building that has high-displacement capacity the *OSL* drift limits are 4% for both the upper structure and the first story. Retrofitting the first story with frames or walls with high-displacement capacity does not change these limits. For the un-retrofitted archetype building that has low-displacement capacity the *OSL* drift limits are 1.25% for both the upper stories and the first story. Retrofitting the first story with frames or walls with high-displacement capacity has the effect of improving the displacement capacity of the entire story. For this reason, the retrofitted first story is given a displacement limit of 4%. The drift limit for the unimproved upper stories remains at 1.25% after retrofit. This is the set of conditions illustrated in Figure E-4.

Table E-1 Drift Criteria, Interstory Drift Ratios in Percent

Name	High-Displacement Capacity (Hd)		Low-Displacement Capacity (Ld)	
	First Story	Upper Stories	First Story	Upper Stories
<i>Onset of Strength Loss, Original Condition</i>	4.0	4.0	1.25	1.25
<i>Onset of Strength Loss, Retrofitted</i>	4.0	4.0	4.0	1.25

E.3 Modeling Details

E.3.1 Software

Perform 3D (Version 4, CSI, 2006), a software package suited for nonlinear response-history analysis was used for the majority of the analysis work. It has an extensive library of nonlinear capabilities mostly built upon the concept of piece-wise linear backbone curves and event-to-event analysis.

Perform 3D does not have elements in its library ready-made to model the types of walls under consideration. The approach taken was to use bar elements (axial load/deformation only) forming cross-struts from floor to floor. These bar elements were assigned material properties calibrated as illustrated in Figure E-5 to achieve the desired hysteretic behavior.

Early in the study, only one pair of compression strut elements were used as illustrated in Figure E-5. Because the elements in Perform 3D are trilinear, there is an elastic portion of the load-drift curve over which no energy would be dissipated. The analysis was refined to account for hysteretic damping at low-drift ratios. This was done by adding another pair of cross-struts to each story making four per story. The yield deflections for each pair of cross-struts are staggered so one pair yields at low levels of drift, the other at larger drift. The composite effect is hysteretic damping at low levels of drift (see Section E.3.3 for additional information on hysteretic damping).

E.3.2 Typical Building Model

The typical building model had four levels at which the cross-struts were vertically restrained. For the translation models, all degrees of freedom except translation were restrained at each floor. The base was fixed. See Figure E-6. The width of each building model was 50 in. and the floor-to-floor was 100 in. At each level, there was one-quarter of the weight, 0.25 kips, so that the total building weight was 1 kip. Thus, the material properties for each strut were normalized to the unit weight of the building.

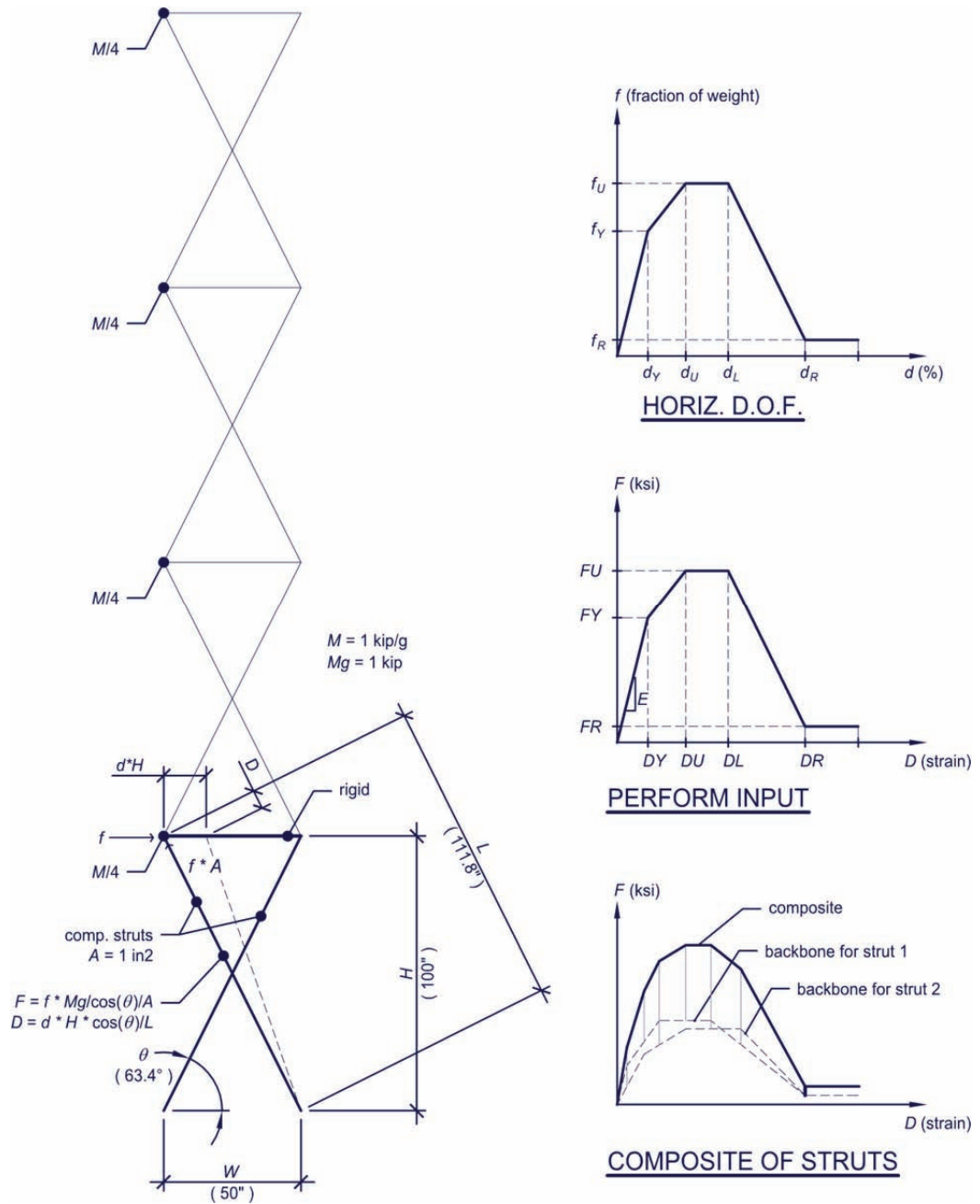

Figure E-5 Schematics illustrating simplified building model bar elements.

To model the first-story retrofit with ductility characteristics of a steel moment frame, a diagonal inelastic bar element was added. This element was calibrated so that the yield drift corresponds to that expected in a typical moment frame used for this type of application. Plywood retrofit options were also modeled. The plywood retrofit options had slightly better performance than those with moment frames. Because the difference in performance was small, both options were treated equally. This study is described in Section E.5.5

E.3.3 Hysteretic Damping

The building models were capable of modeling energy dissipation by inelastic hysteresis. The true hysteretic behavior of these walls was not adequately characterized by full hysteresis loops characteristic of high-displacement capacity steel hysteresis. Rather, the bottom-right and top-left quadrants of the hysteresis loops were relatively vacant, as illustrated in Figure E-7 and Figure E-8.

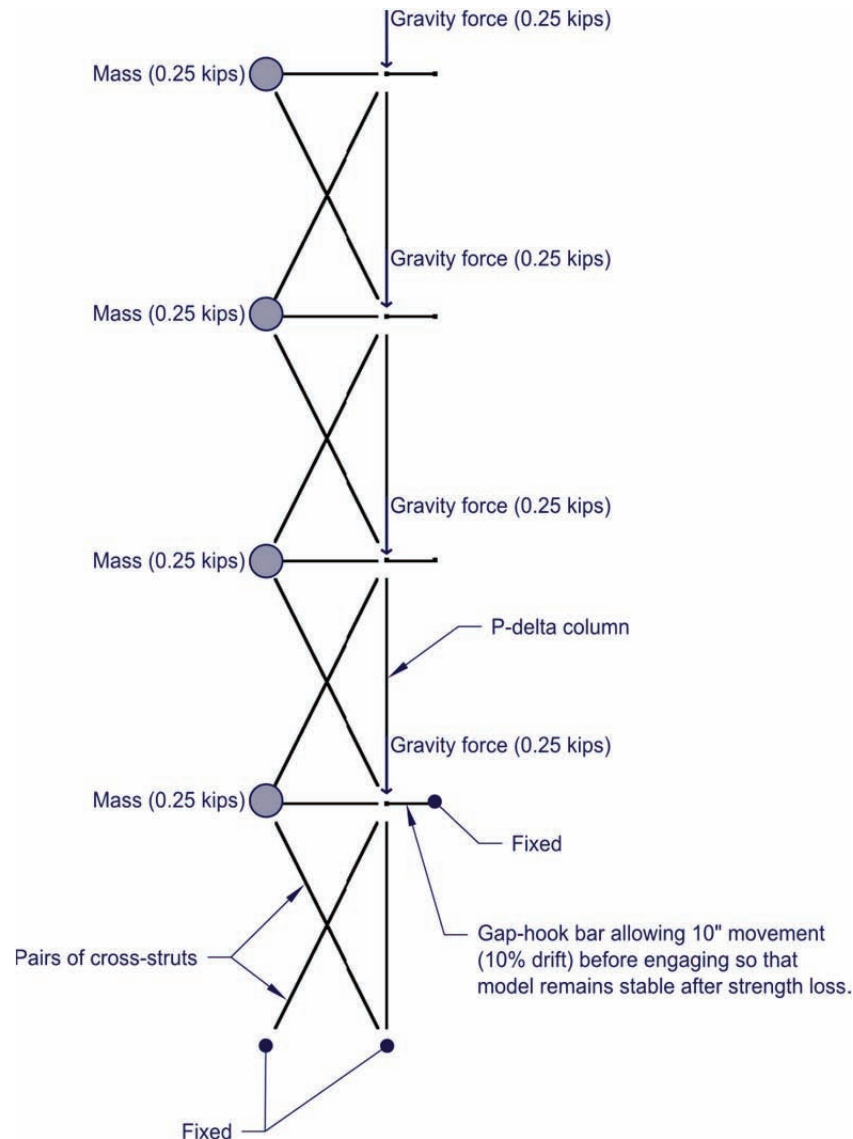

Figure E-6 Screen-snapshot of typical four-story simplified building model in Perform 3D. Typically, twelve simplified buildings were analyzed simultaneously in one model file. The support conditions are shown at each node. The four-level vertical element on the right of each model is the leaning column used to capture P-delta effects.

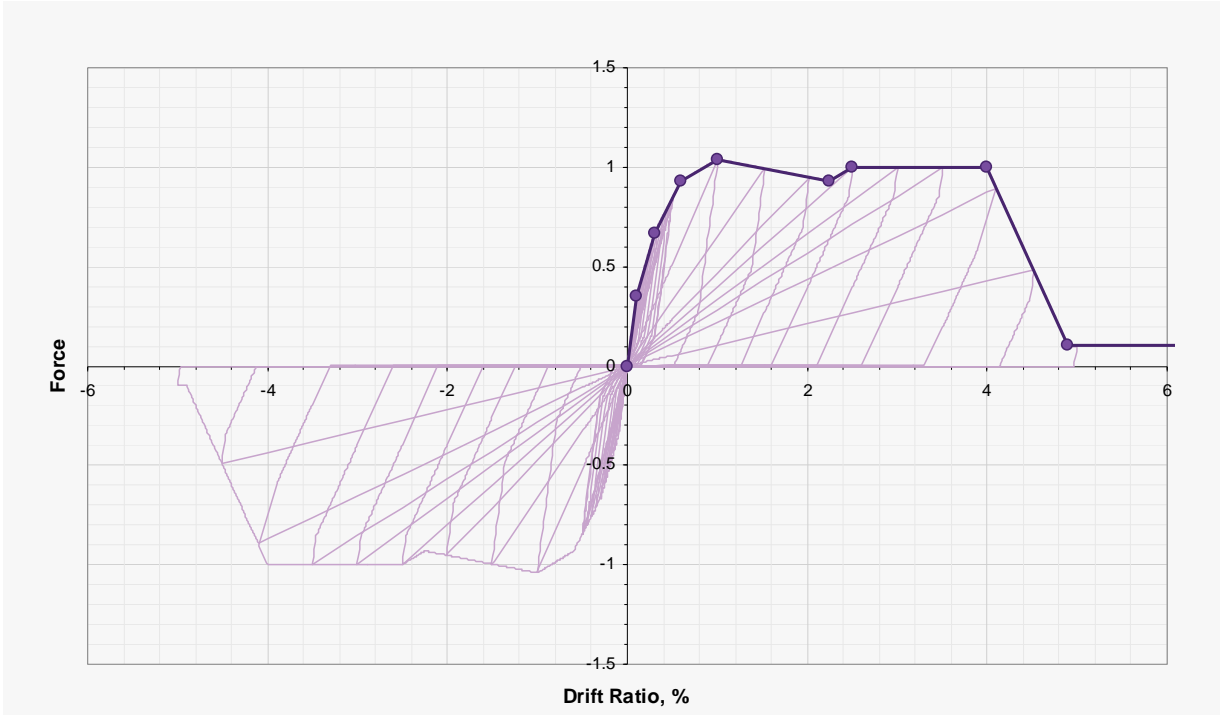

Figure E-7 Plot showing hysteretic behavior of simplified structure models constrained by the backbone curve for the high-displacement capacity material form.

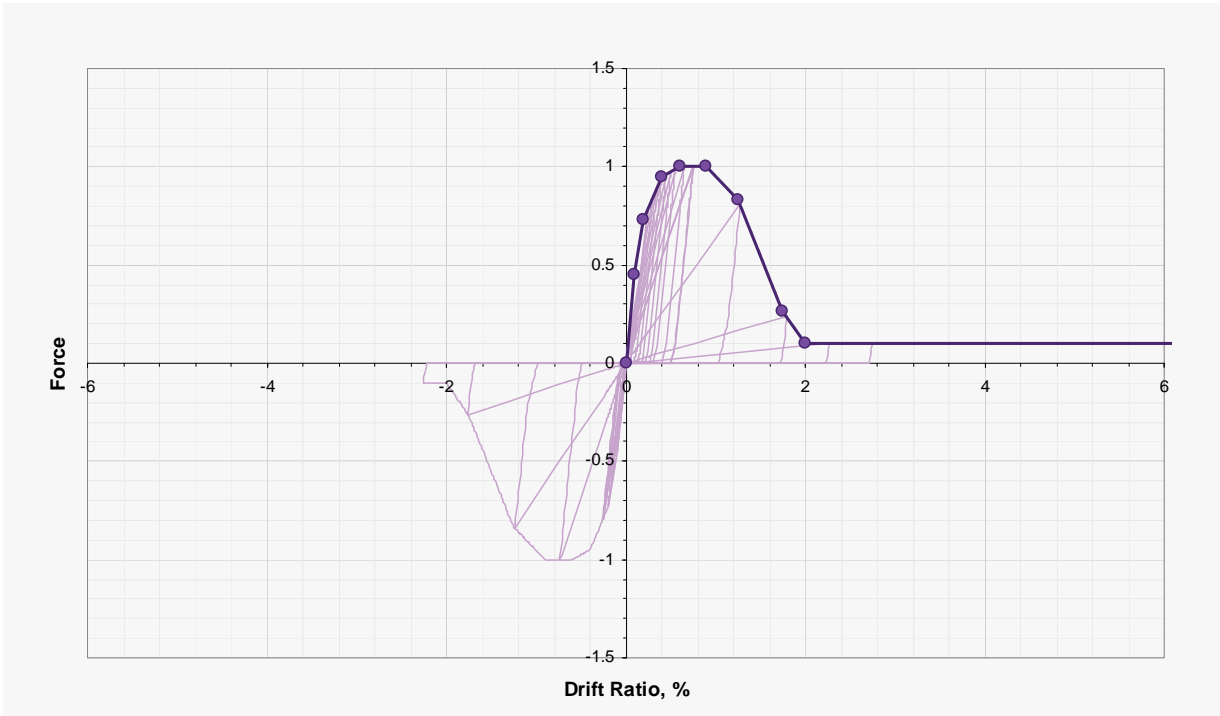

Figure E-8 Plot showing hysteretic behavior of simplified structure models constrained by the backbone curve for the low-displacement capacity material form.

E.3.4 Viscous Damping

All models implemented modal viscous damping of 2% for each mode. This value was deemed to be reasonable when considering large-displacement actions near collapse. It may be somewhat large for estimating small-displacement performance, as hysteretic damping at small displacements was modeled directly.

E.3.5 P-Delta

P-delta effects were modeled in the translational models by adding to each building a “leaning” column loaded axially with 0.25 kips per floor (see Figure E-6). In the torsional models, two “leaning” columns were added, one in each opposing corner, each loaded axially with 0.1 kips at each floor. Perform 3D calculates the P-delta lateral force during the response-history analyses.

Early in the study, the modeling did not take P-delta effects into account. It was determined that P-delta should be addressed, so the models of retrofits were modified to include the P-delta effect. The translational models used to determine the magnitude of retrofit strength needed to optimize seismic performance did not include the P-delta effect. However, once the optimal retrofit strength was determined, the optimally retrofitted models were re-analyzed considering P-delta so that the performance reported in the *Guidelines* takes the effect into account. There is not much variation in the strength of the optimal retrofit, so it is assumed that a model optimally retrofitted not considering P-delta will still be optimally retrofitted if P-delta is considered. Thus, re-analyzing the whole set of models was assumed to be unnecessary.

E.3.6 Accounting for Overturning Effects

The resistance to overturning in the upper stories is complex and difficult to account for on a wall-by-wall basis. Overturning resistance is from dead-load, coupling benefits at perforations, and the so-called “shell effects” due to the interaction between perpendicular walls and floors. To quantify the overall effect, a Perform 3D model was created for a structure similar to the example structure with tuck-under parking shown in Chapter 1, Figure 1-2. The model was modified to have four stories. The model included dead-load effects and all interconnected walls, headers and sills at openings and floor framing. The walls were modeled with fiber elements capable of both shear deformations and overturning. No discrete elements such as straps or hold downs were included. When the overturning resistance, such as from dead load is present, the wall segments roughly follow the load deformation

pattern of a shear model as shown at the lower right of Figure E-9. When overturning restraint is limited, the tension ends of the walls uplift. This reduces the capacity and roughly follows the load-deformation pattern of the fiber model as shown in the upper right of Figure E-9.

The overturning adjustment factor, Q_{ot} , was determined by isolating each story and creating a load-drift curve from a pushover. For the baseline cases, the model was constrained to resist overturning by imposing vertical constraints at the ends of the walls. These constrained models were compared to models free to uplift at the ends of walls. For each pushover, the floor below the story under consideration was laterally fixed. Thus, fixing the second floor tests the second story in shear. The models were tested in both the transverse and longitudinal directions. Results that compare story shear strength for the longitudinal direction are shown in Figure E-10. The reduction for the lack of overturning restraint decreases for lower stories due to the increased dead load. The reduction is also lower when the direction under consideration is perpendicular to the floor or roof framing. Table 4-2 captures these effects. When the floor framing is unknown or mixed, the greater reduction is recommended.

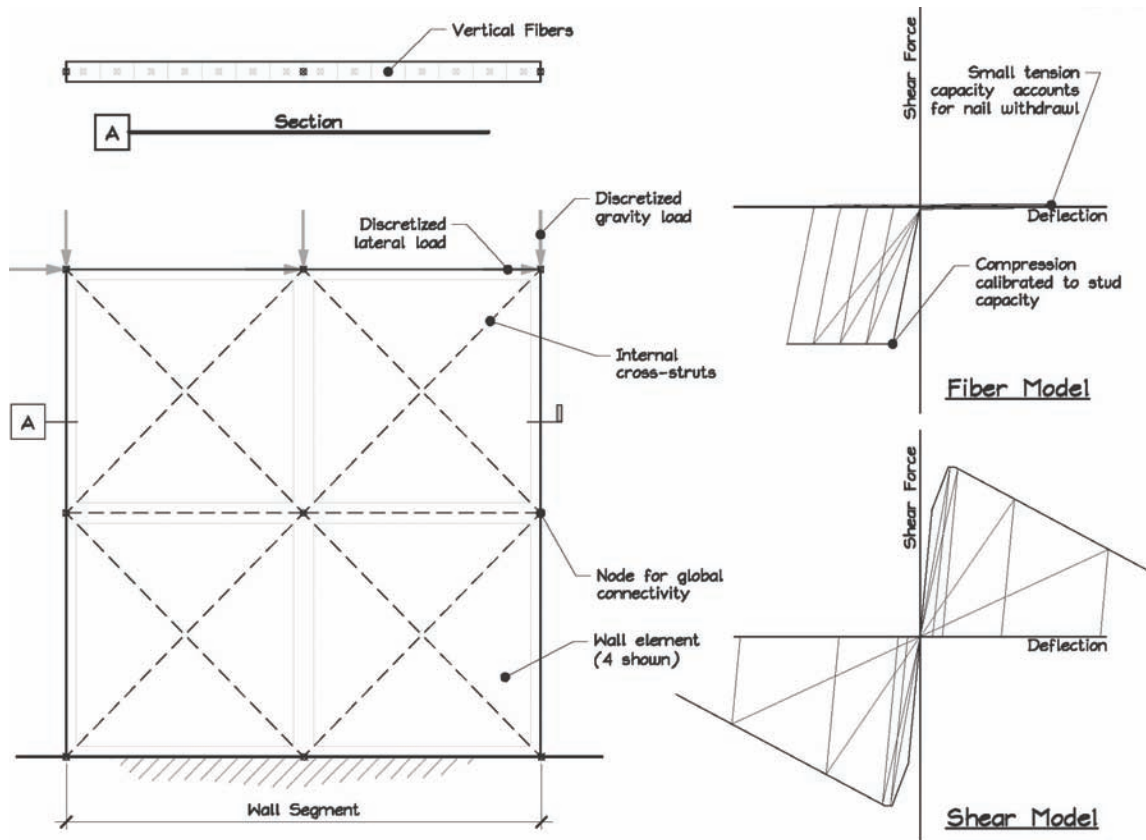
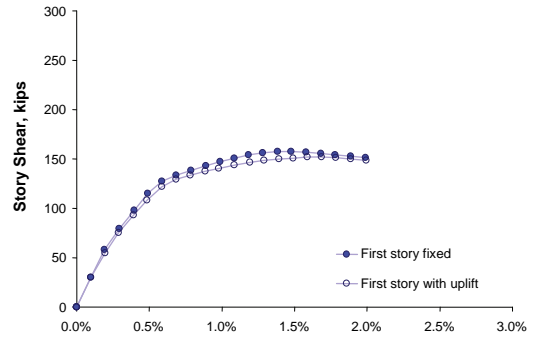
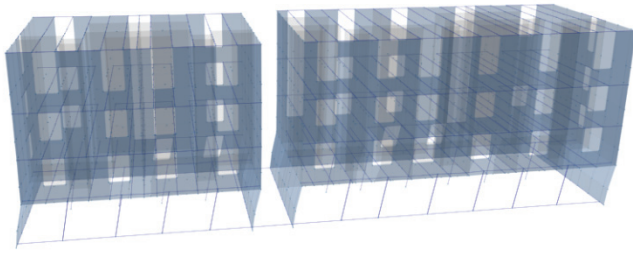
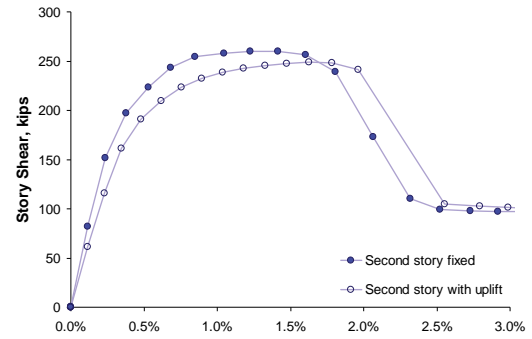
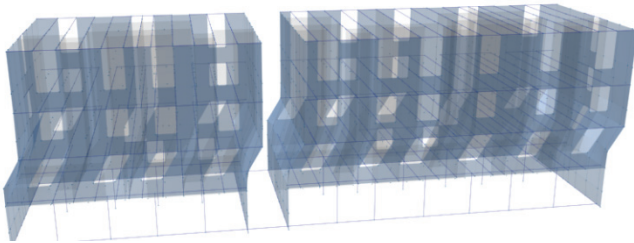

Figure E-9 Schematic of fiber model showing how wall elements were modeled to capture overturning restraint and allow uplift.



a. Pushover fixed at ground level.



b. Pushover fixed at second level.

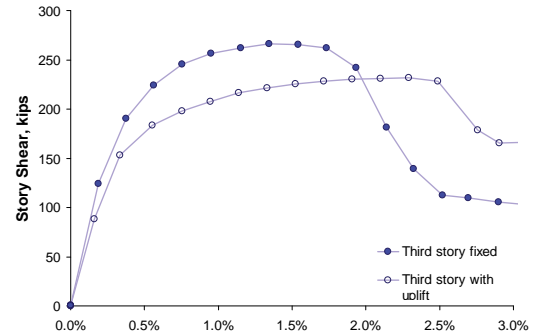
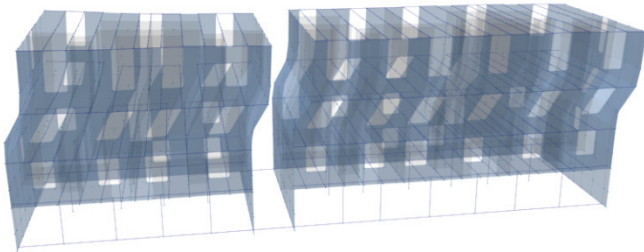

c. Pushover fixed at third level.

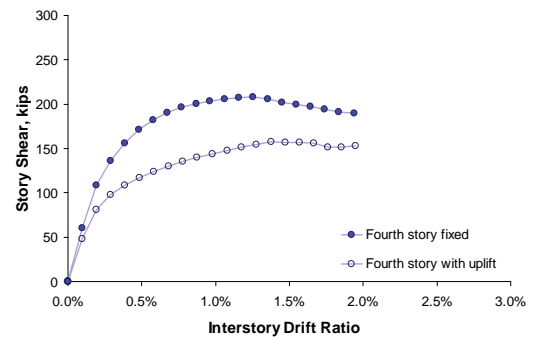
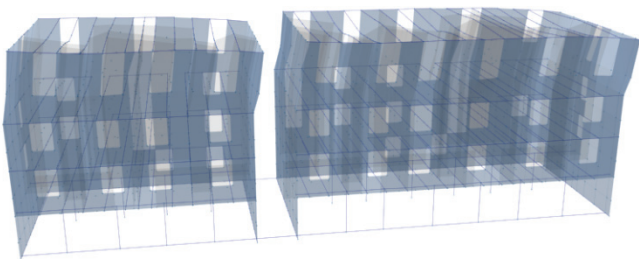

d. Pushover fixed at fourth level.

Figure E-10 Schematic of building displaced shapes and related pushover curves used in study to determine overturning adjustment factor, Q_{ot} .

E.4 Ground Acceleration Records

A suite of 22 ground acceleration records used in the development of the FEMA P-695 Report, *Quantification of Building Seismic Performance Factors* (FEMA, 2009), were selected for these analyses. Each record has two horizontal components that were considered independently for the translational analyses, making 44 records total. All were strong-motion records without near-field effects. They were first scaled so that the geomean of the spectral acceleration of the 44 records equaled 1g at a period of 0.3 seconds. This period was selected as the target, consistent with (1) the period expected for four-story structures and (2) values computed by simplified estimates in common evaluation codes. For the IDA, the set of records were then re-scaled consistently to values ranging from 0.1g to 3.5g, 35 scale factors total (see Figure E-11).

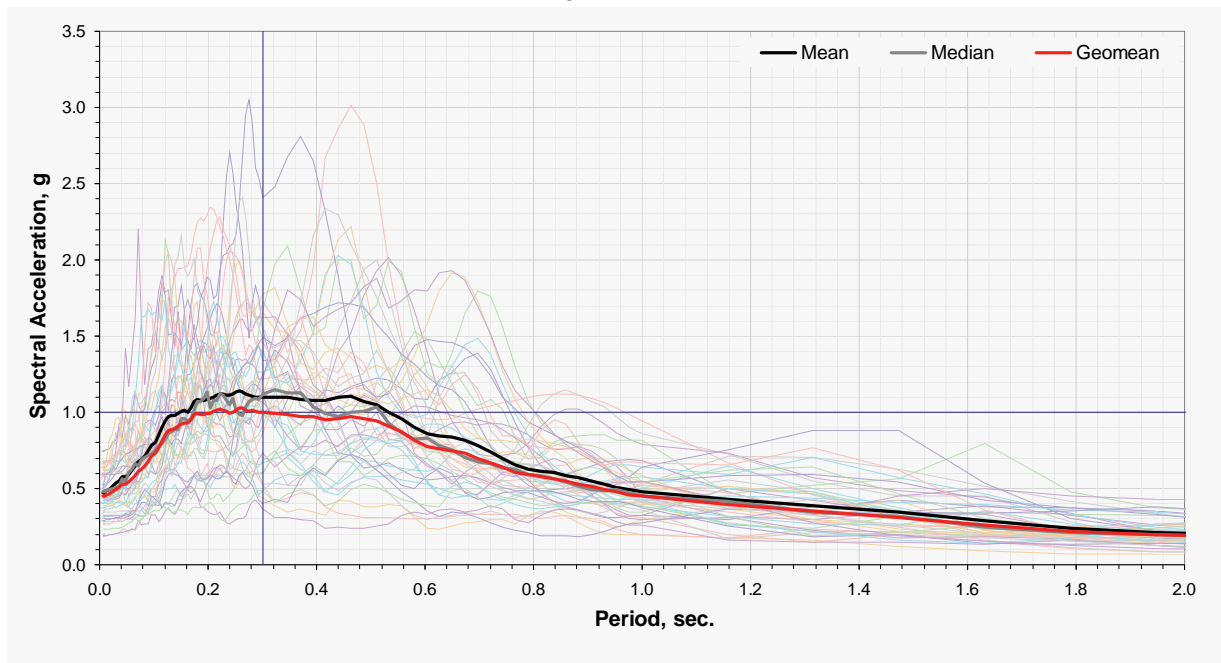

Figure E-11 Plots of acceleration spectra for selected response-history records.

E.5 Translational Analyses

E.5.1 Analysis Flow

The main set of analyses was translational, done with 2-dimensional building models as illustrated in Figure E-6. In this set of analyses, a range of values were assigned to the three parameters of interest (see Section E.2.2) and many combinations were considered.

The objective was both to quantify the response of a range of existing buildings and also to find the first-story retrofit that optimizes seismic

performance. This implied that many existing building archetypes needed to be analyzed to develop a good understanding of the trends of seismic performance for this class of buildings. It also implied that many potential retrofit strengths needed to be considered to find which retrofit strength optimizes seismic performance for each building form.

Figure E-12 illustrates the analysis tree for the translational analyses. The two main branches from which all the building permutations flow were the two material forms. For each material form, there were four base-normalized upper-story strengths considered relative to the total building. For each base-normalized upper-story strength, six weak-story ratios (defined as first-story strength divided by upper-story strength) were considered. For each weak-story ratio, the existing condition was analyzed. A high-displacement capacity first-story retrofit was then added with strength increasing so that the ratio of total retrofitted first-story strength divided by the upper-story strength ranged from the existing weak-story ratio (zero retrofit) to 1.6, a total of (51) building models per base-normalized upper-story strength.

E.5.2 Median Performance

Peak drift values were recovered from the IDA results for all of the building models, each of which is defined by material form, base-normalized upper-story strength, and weak-story ratio. Given a set of drift criteria for the first and upper stories, the IDA drift results were analyzed probabilistically, assuming a lognormal distribution. The median earthquake spectral acceleration response and lognormal standard deviation were computed so that the lognormal Cumulative Distribution Function (CDF) minimizes the error relative to the results under a given set of drift criteria. This median represents the value at which the probability of exceedance of the drift criteria is 50%. Because the ground acceleration records were scaled to a spectral acceleration response of 1g at a period of 0.3 seconds, this median earthquake spectral acceleration was taken to be the median “spectral acceleration capacity,” S_{μ} , of the structure for the drift criteria under consideration. Thus, at the median spectral acceleration capacity, S_{μ} , the probability of exceedance of the specified drift criteria is 50%.

In Chapter 5 of the *Guidelines* a set of drift criteria is defined to represent the onset of significant strength loss. Using these criteria, the median spectral acceleration capacities of all the building models were computed and curve-fitted as illustrated in Figure E-13 and Figure E-14. Linear curve-fitting was considered inadequate in terms of accuracy at fitting the data. Given the basic form of the curve,

$$S_{\mu} = (\alpha_U + \alpha_W A_{W,x}) A_U^{\gamma_U} \quad (E-1)$$

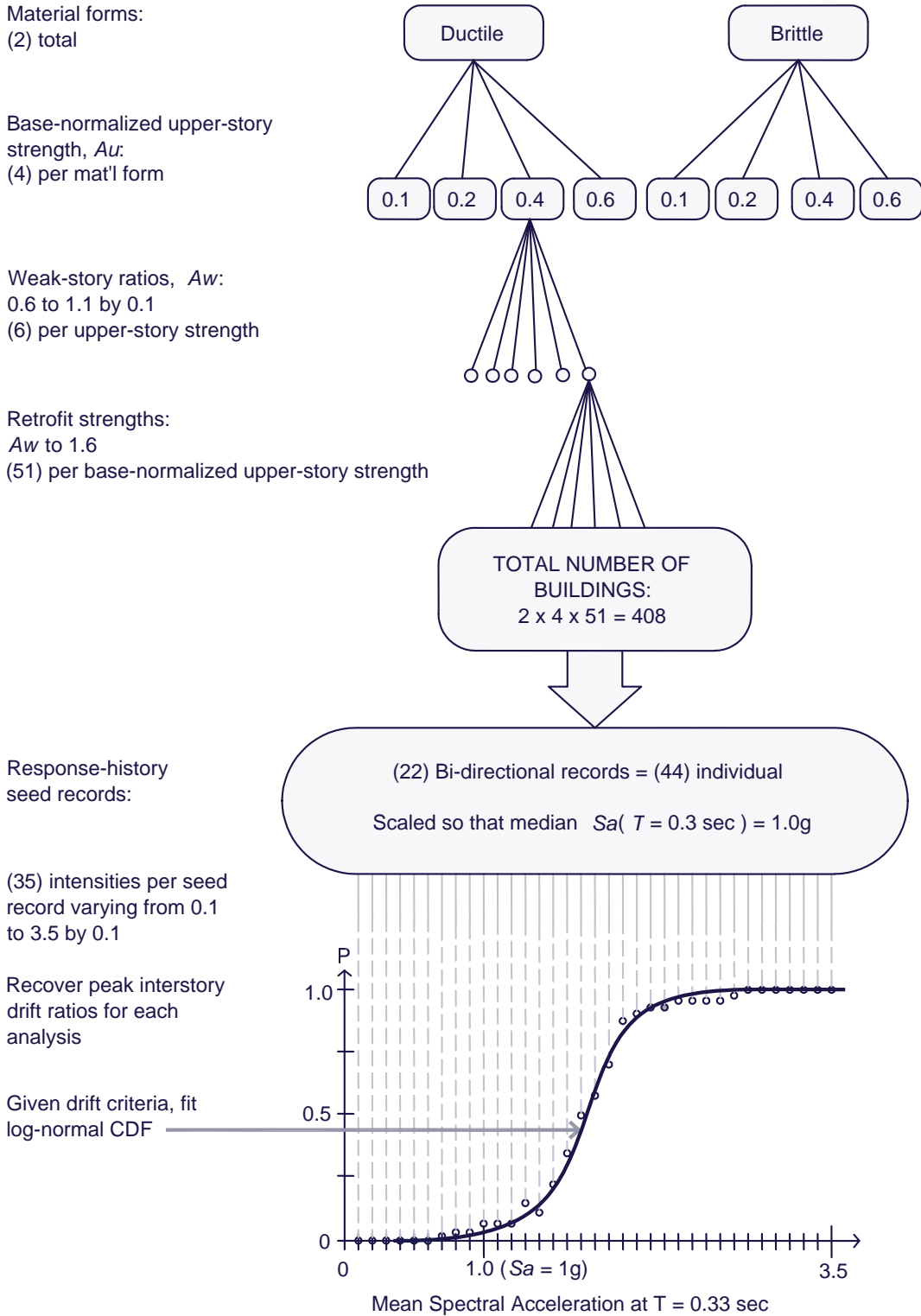

Figure E-12 Flow chart used in translational analyses to optimize retrofit. Ductile materials are those with high-displacement capacity; brittle materials are those with low-displacement capacity. CDF = Cumulative Distribution Function. S_a = spectral acceleration. T = period of oscillation. P = probability of not being exceeded.

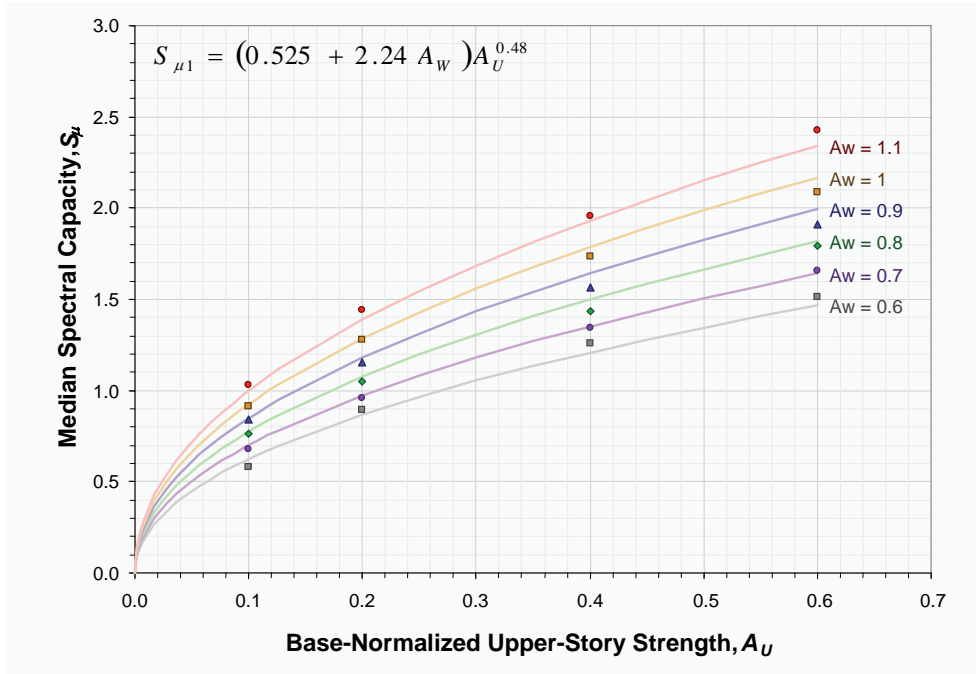

Figure E-13 Curve fits for IDA results relating median spectral acceleration capacity (considering *Onset of Strength Loss* drift criteria) to base-normalized upper-story strength, A_U for various weak-story ratios A_w . Strength degradation ratio, $C_D = 1.0$, and torsion coefficient $C_T = 0.0$.

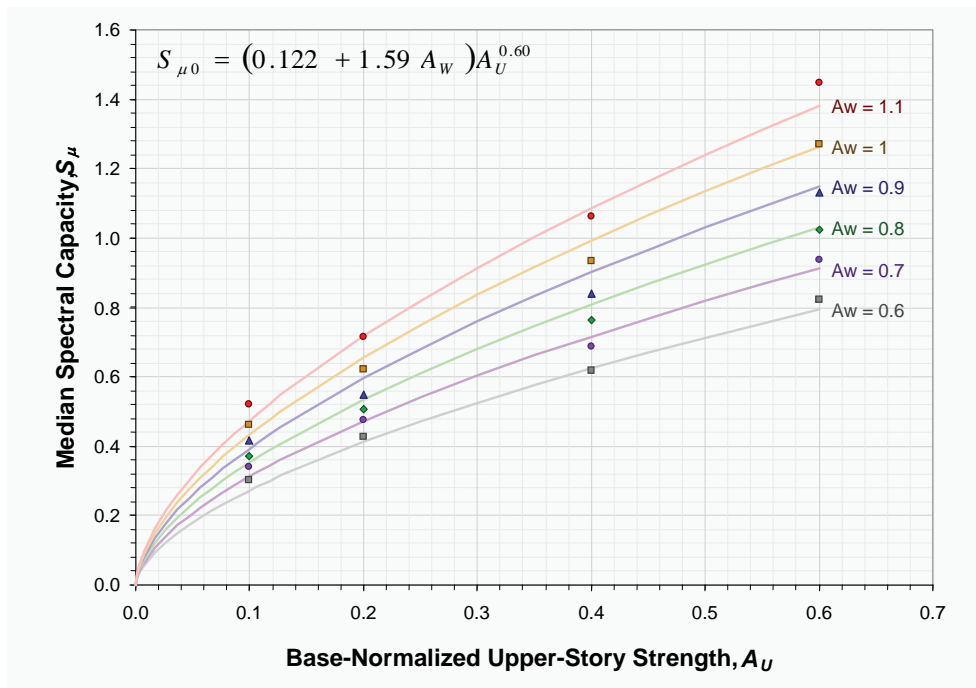

Figure E-14 Curve fits for IDA results relating median spectral acceleration capacity (considering *Onset of Strength Loss* drift criteria) to base-normalized upper-story strength, A_U for various weak-story ratios A_w . Strength degradation ratio, $C_D = 0.0$, and torsion coefficient, $C_T = 0.0$.

the coefficients α_U , α_W , and γ_U were computed to minimize the error relative to the entire field of the analysis results. Thus, the curve may fit certain values of A_W better than others or certain ranges of A_U better than others, but the error on the whole was minimized. There exist many other choices for the basic form of the curve, but given all of the uncertainties inherent in the problem under consideration and the mandate for *Guidelines* that are simple yet effective, the chosen form was deemed to be an adequate balance.

E.5.3 Interpolation for Intermediate Values of C_D

As is discussed in the following sections, the first-story strength was varied to represent adding new retrofit strength. If the unretrofitted condition initially has a strength degradation ratio, C_D of zero, adding retrofit elements with a C_D of one causes the C_D value of the retrofitted condition to be between zero and one. The spectral acceleration capacity of these models provides the basis for interpolating between C_D values of zero and one.

Initially, it was assumed that linear interpolation on C_D would be adequate. However, that assumption proved overly unconservative when the curve fit was plotted against the analytical results, as illustrated in Figure E-15. The results in the graph are from buildings with initial C_D ratios of zero and A_W ratios varying from 0.6 to 1.1. The retrofitted A_W ratio is approximately 1.3

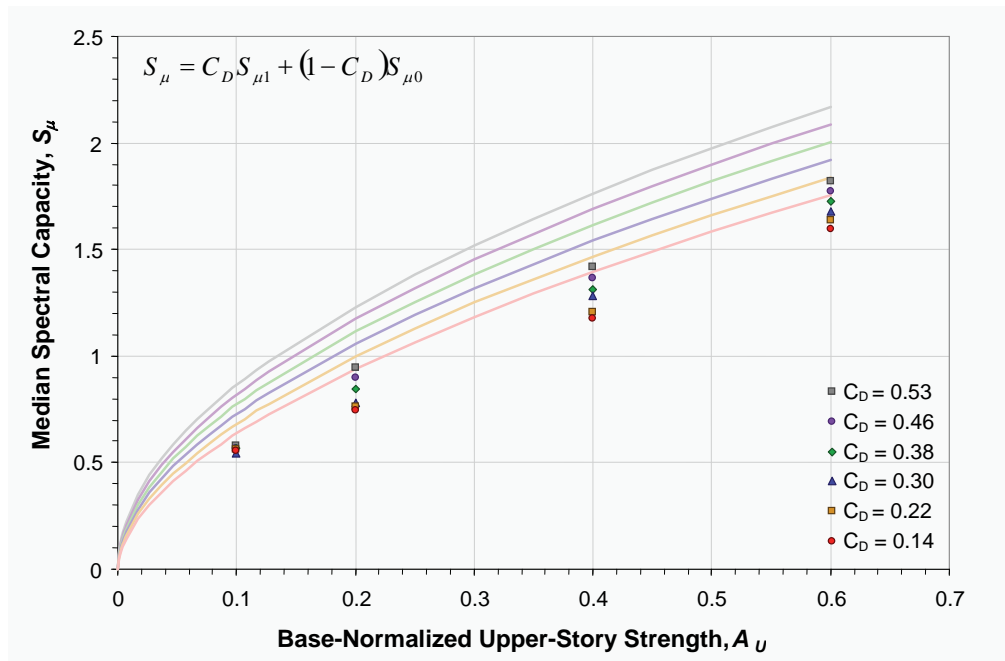

Figure E-15 Curve fits for IDA results using *linear* interpolation model for C_D relating median spectral acceleration capacity (considering *Onset of Strength Loss* drift criteria) to base-normalized upper-story strength, A_U for various values of strength degradation ratio, C_D , and torsion coefficient, $C_T = 0.0$.

for reasons discussed in the following sections that explore the optimal retrofitted first-story strength. Figure E-15 shows that, for the intermediate values of C_D studied, the median spectral acceleration capacity predicted using linear interpolation was consistently larger, and often significantly larger than the analytical results would indicate. Physically, this means that starting with a structure with a low C_D ratio and increasing it by some amount does not lead to a performance enhancement proportional to the change in C_D . A different model for interpolation was clearly needed.

The interpolation on C_D was assumed to be of the form:

$$S_\mu = C_D^x S_{\mu 1} + (1 - C_D^x) S_{\mu 0} \quad (\text{E-2})$$

where S_μ and $S_{\mu 0}$ are the two extreme values of spectral acceleration capacity for $C_D = 1$ and $C_D = 0$, respectively.

Choosing the value for the exponent, $x = 3$ adequately reduced the error over the field of data (see Figure E-16). For simplicity, a more precise number was not used. Figure E-17 illustrates the error between the analytical results and the linear and cubic interpolation assumptions. For each assumption, the

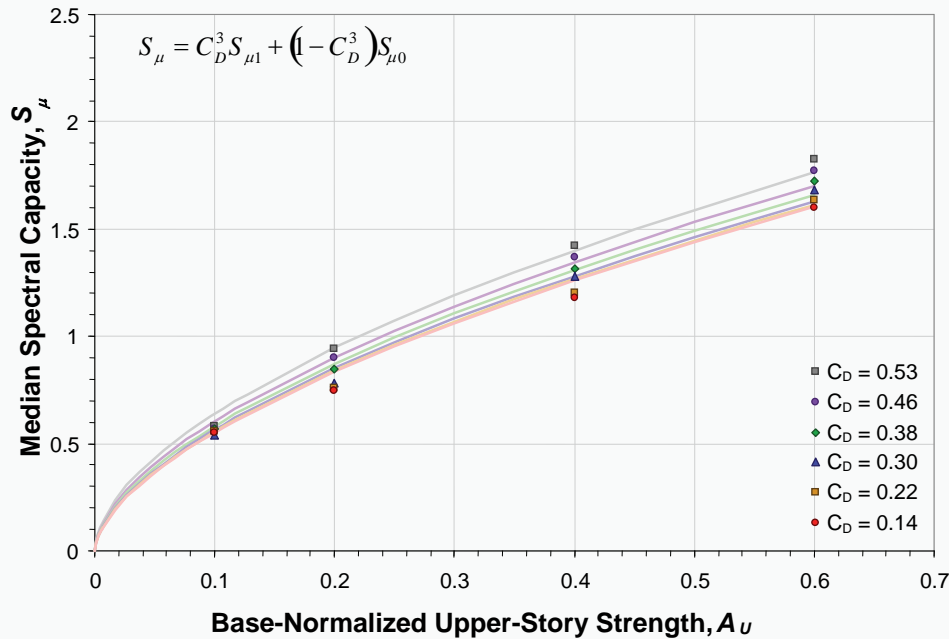

Figure E-16 Curve fit for IDA results using cubic interpolation model for C_D relating median spectral acceleration capacity (considering *Onset of Strength Loss* drift criteria) to base-normalized upper-story strength, A_U , for various values of strength degradation ratio, C_D , and torsion coefficient, $C_T = 0.0$.

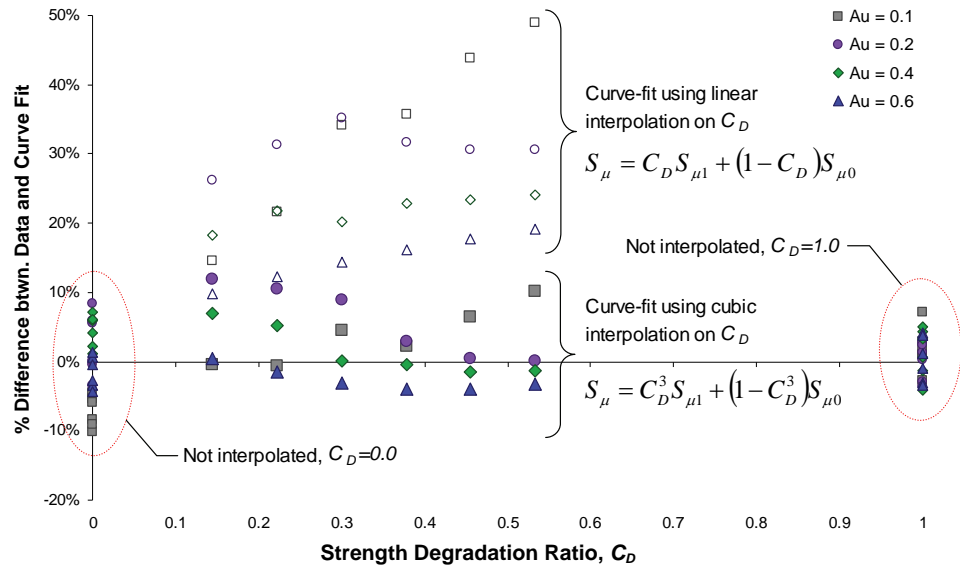

Figure E-17 Plots of error data, as a function of strength degradation ratio, C_D , and base-normalized upper-story strength, A_U , for linear and cubic interpolation models for estimating median spectral acceleration capacity, S_μ .

percent difference is plotted (vertical axis) against the strength degradation ratio, C_D (horizontal axis). Whereas linear interpolation shows error that is generally large (between 10% and 50%) and always positive (i.e. over-predicting spectral capacity), the cubic assumption shows error less than 10% and has some balance between positive and negative error.

E.5.4 Adjustment for Uncertainty

Given a particular building model and set of drift criteria, the number of response-history records that cause exceedance generally increases as the earthquake ground shaking increases. The probability distribution will center about the median earthquake spectral acceleration response found by performing a log-normal curve fit. The dispersion around the median spectral acceleration response is characterized by the log-normal standard deviation of the curve-fit, quantifying uncertainty in the structural response due to the variability of the ground-motion time-histories. There are other uncertainties that exist and may be taken into account by adjusting the standard deviation.

For this study, three parameters of uncertainty were considered:

- Initial stiffness, K ,
- Peak strength, F_U , and
- Drift ratio at strength loss, D_L .

By varying each parameter independently and running the IDA on the variations, partial derivatives (or gradients) were computed relating the change in the natural logarithm of the median spectral acceleration response, μ , to the change in the natural logarithm of the parameter. This was done for building models with several uniform strength ratios (0.1, 0.2, 0.4) for each material form. The variations are illustrated in Figure E-18, Figure E-19, and Figure E-20.

Using the gradients, one can compute a new value for the log-normal standard deviation, β_{total} , adjusted to account for material uncertainties in the parameters of interest. This is given by:

$$\beta_{total} = \sqrt{\sum_{i=1}^3 \sum_{j=1}^3 \left(\frac{\partial \ln(\mu)}{\partial \ln(X_i)} \frac{\partial \ln(\mu)}{\partial \ln(X_j)} \rho_{ij} \beta_i \beta_j \right)} + \beta_{TH}^2 \quad (E-3)$$

where:

- β_{total} = Log-normal standard deviation adjusted to account for material uncertainties,
- X_i = Parameter, i , either K , F_U , or D_L ,
- μ = Median earthquake spectral acceleration response satisfying log-normal curve-fit,
- ρ_{ij} = Correlation coefficient of $\ln(X_i)$ and $\ln(X_j)$ from material testing,
- β_i = Standard deviation of natural logarithm parameter X_i from material testing, and
- β_{TH} = Log-normal standard deviation resulting from curve fit to IDA results using median material properties.

The material statistics tabulated in Table E-2 were computed from the tests considered for these *Guidelines* as documented in Appendix D. Little experimental data of sheathing materials exists that was useful in the current context. The data set from which the statistics were computed is small, especially for materials like stucco and lath and plaster. Thus, the statistics for the expected behavior of these materials may not be very accurate. Further research and testing to more thoroughly understand the median behavior and variability of the finish materials is therefore warranted.

Adjustments were made to convert the wood structural panel test data from multiple sources onto a basis consistent with the current context, as documented in Appendix D. These adjustments may have artificially decreased the variability of the backbone. In addition, it is noteworthy that the sizes of the data sets were not very large: four or more for the various 8d nailing configurations and two for the 10d nailing configurations.

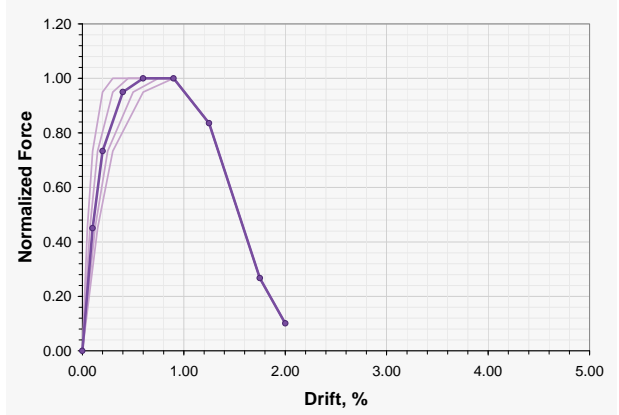
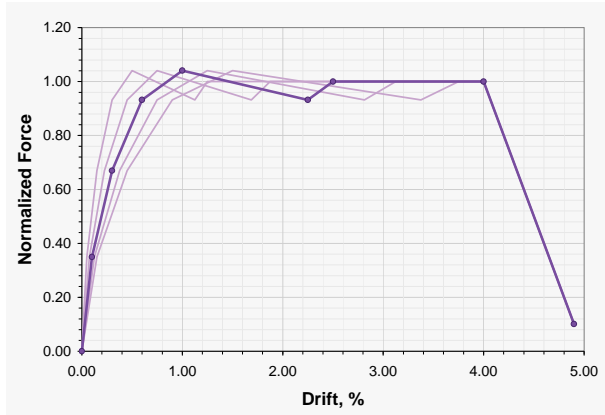

Figure E-18 Plots showing stiffness variations in high-displacement capacity materials (left) and low-displacement capacity materials (right) as a function of normalized force (acceleration response) and drift ratio.

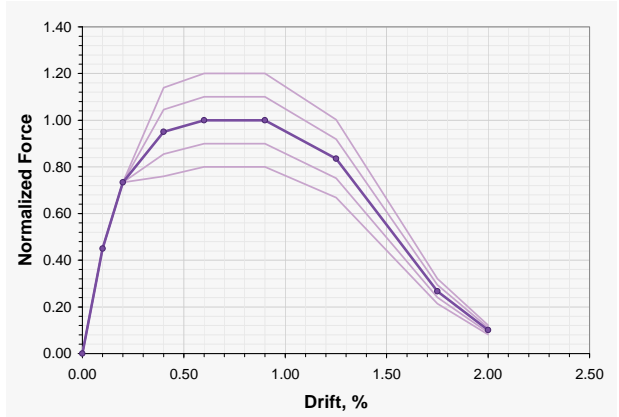
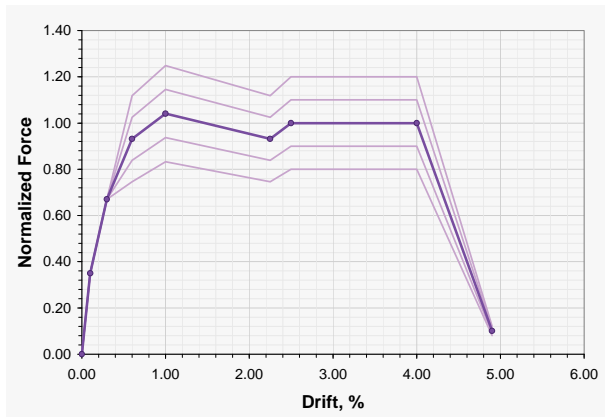

Figure E-19 Plots showing strength variations in high-displacement capacity materials (left) and low-displacement capacity materials (right) as a function of normalized force (acceleration response) and drift ratio.

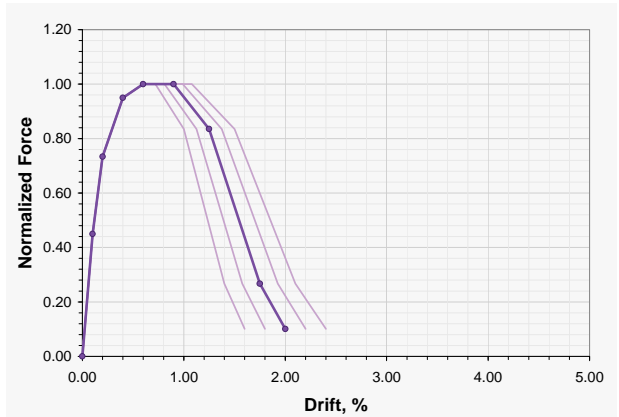
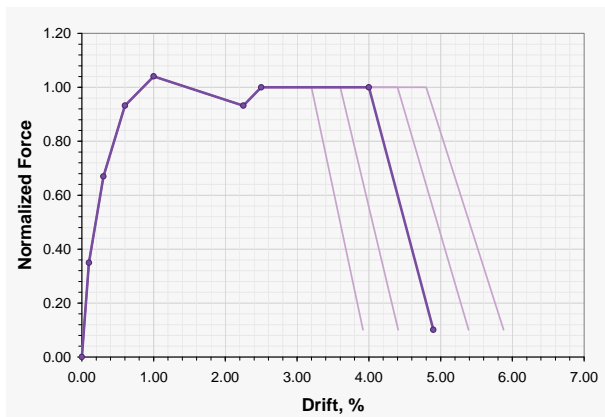

Figure E-20 Plots showing variations in drift at loss of strength in high-displacement capacity materials (left) and low-displacement capacity materials (right) as a function of normalized force (acceleration response) and drift ratio.

Table E-2 Computed Material Statistics: β_x = Log-Normal Standard Deviation of Variable x , and ρ_{xy} = Correlation Coefficient of the Natural Logarithm of Variable x and y . K = Initial Stiffness; F_U = Peak Strength, and D_L = Drift Ratio at Strength Loss

	Low-Displacement Capacity	High-Displacement Capacity
β_K	0.260	0.158
β_{F_U}	0.214	0.075
β_{D_L}	0.259	0.076
ρ_{K,F_U}	0.975	0.823
ρ_{K,D_L}	-0.234	-0.306
ρ_{F_U,D_L}	-0.180	0.050

Gradients plots showing changes in initial stiffness, K , peak strength, F_U , and drift ratio at strength loss, D_L , for different materials, as a function of earthquake shaking intensity, are plotted for the onset of strength loss set of drift criteria in Figure E-21, Figure E-22, and Figure E-23, respectively. Similar gradients were computed for the other drift criteria but are not shown here. Clearly from these figures, the parameter with the largest gradient is peak strength.

Curve-fitting the IDA results, the value of β_{TH} varies from 0.32 to 0.45 for the models with the low-displacement capacity (Ld) material and 0.32 to 0.40 for the high-displacement capacity (Hd). The first term in Equation E-3 is the contribution of the material to the total uncertainty, defined as β_M^2 . Combining the material statistics in Table E-2 with the gradients shown in Figure E-21, Figure E-22, and Figure E-23, the adjustment for material uncertainty, β_M^2 , is computed to be only 0.0196 for the models with the low-displacement capacity (Ld) material and 0.0009 for the high-displacement capacity (Hd). This causes the range of β_{total} to become 0.35 to 0.47 for the models with the low-displacement capacity (Ld) material and 0.32 to 0.41 for the high-displacement capacity (Hd), a nearly negligible change.

It was considered that the low β values in the material statistics might be inaccurate, so the material statistics were modified as tabulated in Table E-3. This caused computed β_M^2 to become 0.04 for the models with the low-displacement capacity (Ld) material and 0.0144 for the high-displacement capacity (Hd). This had a very minor effect on β_{total} , causing the range to become 0.38 to 0.49 for the models with the low-displacement capacity (Ld) material and 0.34 to 0.42 for the high-displacement capacity (Hd), still a very small change.

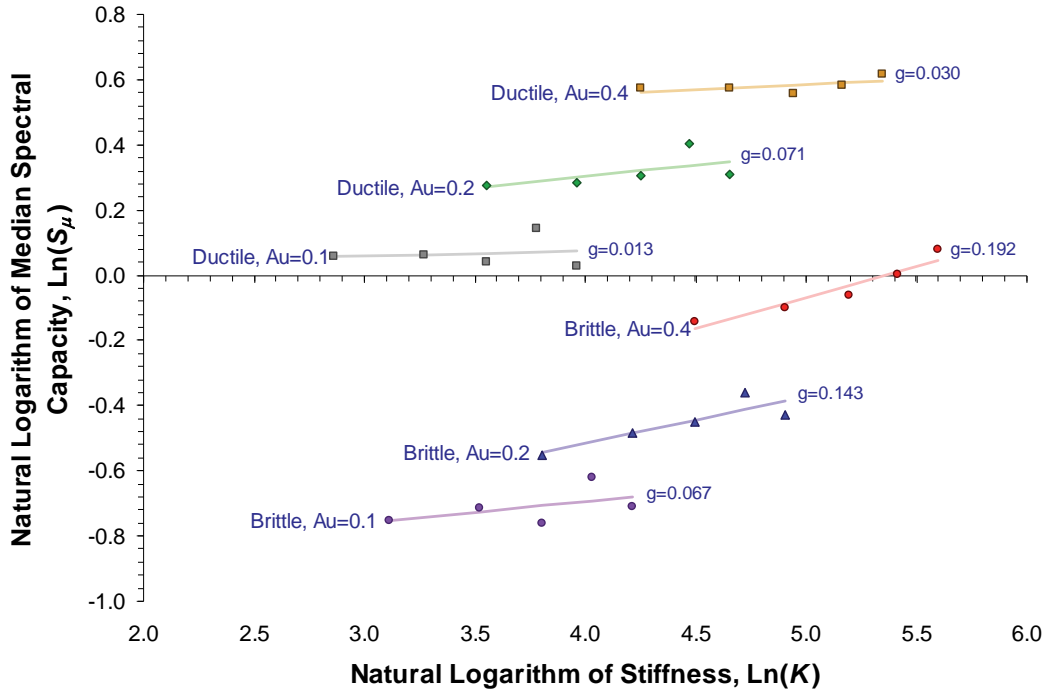

Figure E-21 Plot showing effect of variation in stiffness, K , on median spectral capacity, S_{μ} , for various configurations of material form and upper-story strength ratio, A_U . The median spectral capacity is determined using the Onset of Strength Loss (OSL) set of drift criteria. Ductile materials are those with high-displacement capacity ($C_D=1.0$). Brittle materials are those with low-displacement capacity ($C_D=0.0$). The value, g , is the gradient (slope) quantifying the effect of the variation.

Table E-3 Modified Material Statistics: β_x = Log-Normal Standard Deviation of Variable x , and ρ_{xy} = Correlation Coefficient of the Natural Logarithm of Variable x and y . K = Initial Stiffness; F_U = Peak Strength, and D_L = Drift Ratio at Strength Loss

	Low-Displacement Capacity	High-Displacement Capacity
β_K	0.4	0.4
β_{F_U}	0.4	0.4
β_{D_L}	0.4	0.4
ρ_{K,F_U}	0.5	0.5
ρ_{K,D_L}	-0.5	-0.5
ρ_{F_U,D_L}	-0.5	-0.5

Regardless of the uncertainty in the material properties, the gradients in the seismic response relative to material variations are not large enough to cause significantly more overall uncertainty. Other sources of uncertainty and important issues not evident from the tests include:

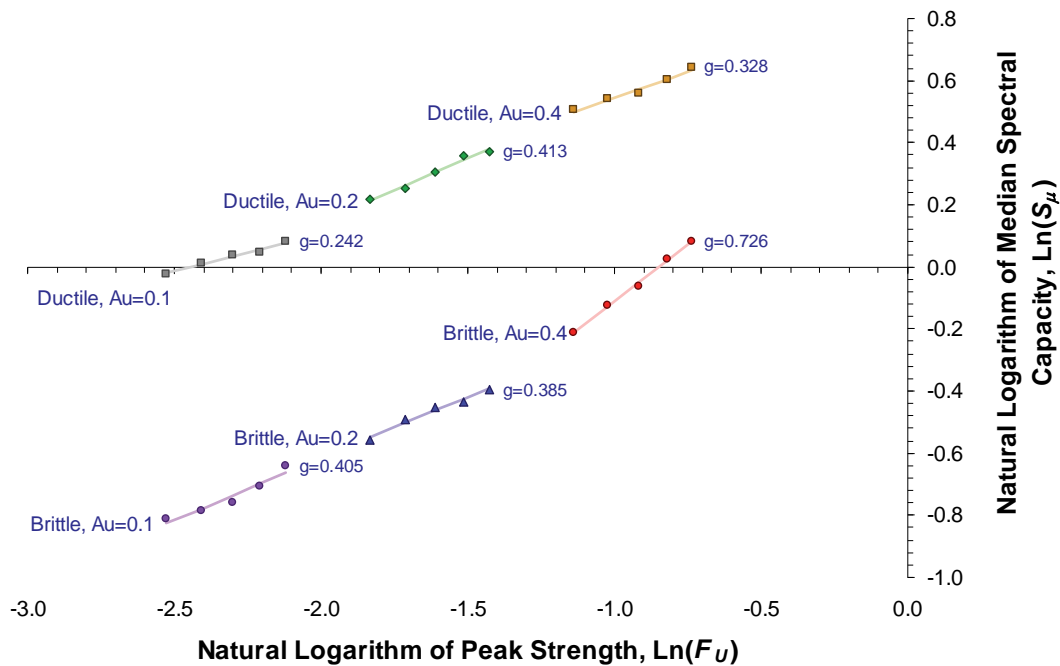

Figure E-22 Plot showing effect of variation in peak strength, F_U , on median spectral capacity, S_{μ} for various configurations of material form and upper-story strength ratio, A_U . The median spectral capacity is determined using the Onset of Strength Loss (OSL) set of drift criteria. Ductile materials are those with high-displacement capacity ($C_D=1.0$). Brittle materials are those with low-displacement capacity ($C_D=0.0$). The value, g , is the gradient (slope) quantifying the effect of the variation.

- Inherent uncertainties in the process of surveying the existing building like measurements and identification of sheathing materials;
- Workmanship in test specimens, which is likely to be better quality and uniformity than that found in the field; and
- There may be damage potential that cannot be identified by selectively surveying material properties.

Table E-4 summarizes the conclusions regarding the treatment of uncertainty. Because of the factors identified above, the values for β_{total} , which are denoted as β , were artificially inflated to 0.6 for low-displacement capacity materials and 0.5 for high-displacement capacity materials. All results dependent on β are based on these values unless noted otherwise.

Variations in β do not affect the median response (Probability = 0.5), by definition, of the log-normal CDF. Figure E-24 illustrates the effect of increasing β from 0.4 to 0.5 and 0.6. The effect becomes more pronounced further from the median and for higher values of spectral acceleration response.

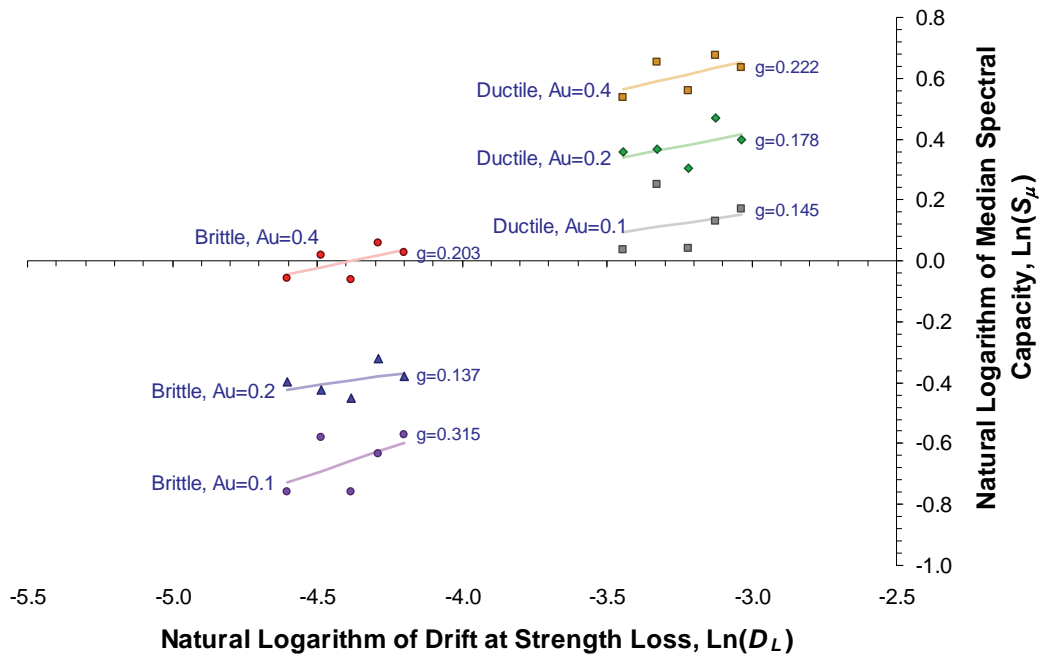

Figure E-23 Plot showing effect of variation in drift at strength loss, D_L , on median spectral capacity, S_{μ} , for various configurations of material form and upper-story strength ratio, A_U . The median spectral capacity is determined using the Onset of Strength Loss (OSL) set of drift criteria. Ductile materials are those with high-displacement capacity ($C_D=1.0$). Brittle materials are those with low-displacement capacity ($C_D=0.0$). The value, g , is the gradient (slope) quantifying the effect of the variation.

Table E-4 Summary of Composite Log-Normal Standard Deviation, β_{total} (also known as β)

	Low-Displacement Capacity	High-Displacement Capacity
From Time-Histories without adjustment for material uncertainties	0.32 to 0.45	0.32 to 0.45
Based on material statistics	0.35 to 0.47	0.32 to 0.40
Based on modified material statistics	0.38 to 0.49	0.34 to 0.42
Selected for Guidelines	0.6	0.5

E.5.5 Assessment and Probability of Exceedance

Given the median spectral acceleration capacity, S_{μ} , and dispersion, β , the spectral capacity, S_c , at any desired drift-limit probability of exceedance, POE , may be recovered from the log-normal Cumulative Distribution Function (CDF). As discussed in the previous section, it is deemed

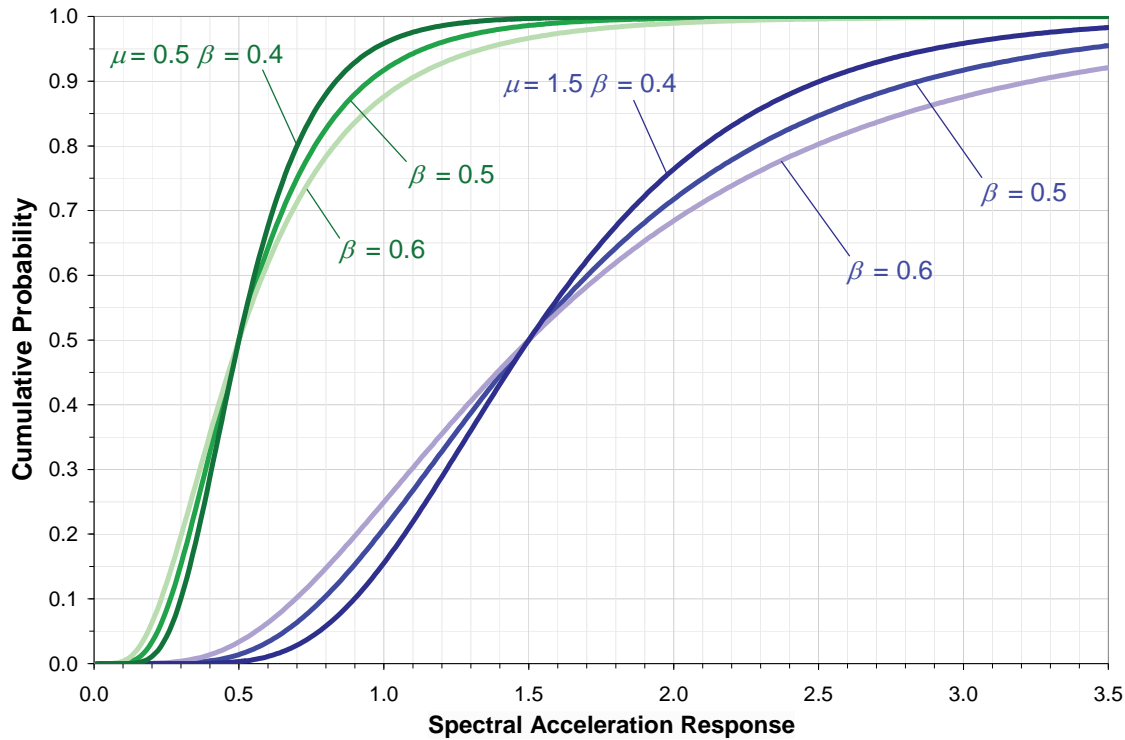

Figure E-24 Cumulative Distribution Function plots showing effect of increasing log-normal standard deviation, β , as a function of spectral acceleration response.

appropriate to simplify the dispersion to just two values depending on the strength degradation ratio, C_D . For a given value of β , the log-normal distribution has the property that the ratio, S_c / S_μ for a specified drift limit POE is constant with respect to varying values of S_μ as illustrated in Figure E-25. In other words, for a drift limit $POE = 0.2$ and $\beta = 0.5$, the ratio of S_c / S_μ is 0.66 for any value of S_μ . This implies that for a specified drift limit POE , an adjustment factor can be identified to convert the median spectral acceleration capacity to the spectral acceleration capacity with the specified drift limit POE . Taking advantage of this property of the log-normal distribution, the evaluation equations in Chapter 5 and the retrofit equations in Chapter 6 can accommodate any drift limit POE through the drift limit POE modification factors, $\alpha_{POE,0}$ and $\alpha_{POE,1}$.

It is presumed that most practicing engineers do not have a working knowledge of the log-normal distribution, and it is not a closed-form equation that can be manipulated with a hand calculator. For a given median spectral acceleration capacity, S_μ and dispersion, β , Microsoft Excel has a function for computing the drift limit POE at a specified value of S_c :

$$POE = \text{LognormDist}(S_c, \ln(S_\mu), \beta) \quad (\text{E-4})$$

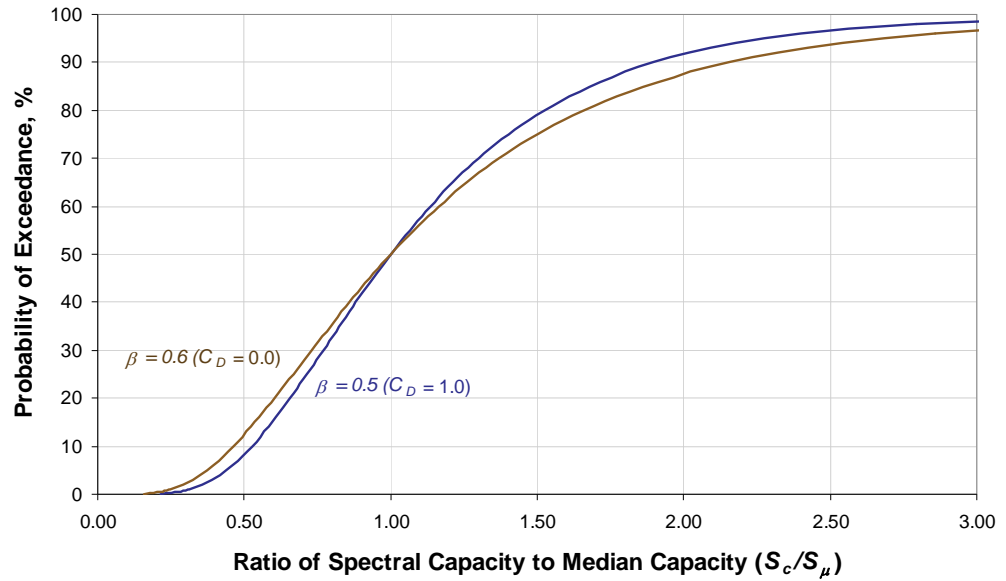

Figure E-25 Plots of ratio of spectral acceleration capacity, S_c , at varying values of drift limit POE to median spectral capacity.

and conversely the value S_c at a specified drift limit POE , given the median and dispersion:

$$S_c = \text{LogInv}(POE, \ln(S_\mu), \beta) \quad (\text{E-5})$$

The *Guidelines* could define the drift limit POE modification factor, α_{POE} , in terms of these black-box functions, but this complicates the *Guidelines* somewhat and could lead to confusion and user error. It was deemed to be an adequate and reasonable compromise to linearize the log-normal distribution focusing on a limited range of probabilities and the two selected values for the dispersion, β :

$$\alpha_{POE,1} = 0.0119POE + 0.4102, \text{ for } C_D = 1.0 \quad (\text{E-6})$$

$$\alpha_{POE,0} = 0.0133POE + 0.3298, \text{ for } C_D = 0.0 \quad (\text{E-7})$$

where:

POE = probability of exceedance represented as a percentage. For example, for a 20% probability of exceedance, the drift limit $POE = 20$.

As illustrated in Figure E-26, the error relative to the linear approximation is less than 10% over the range of probabilities of exceedance from 5% to 70% and is less than 5% over a range of probabilities from 6% to 65%. This range of probabilities encompasses the range of interest in the *Guidelines*, so the simplification comes with no cost in terms of the applicability of the evaluation and retrofit methods.

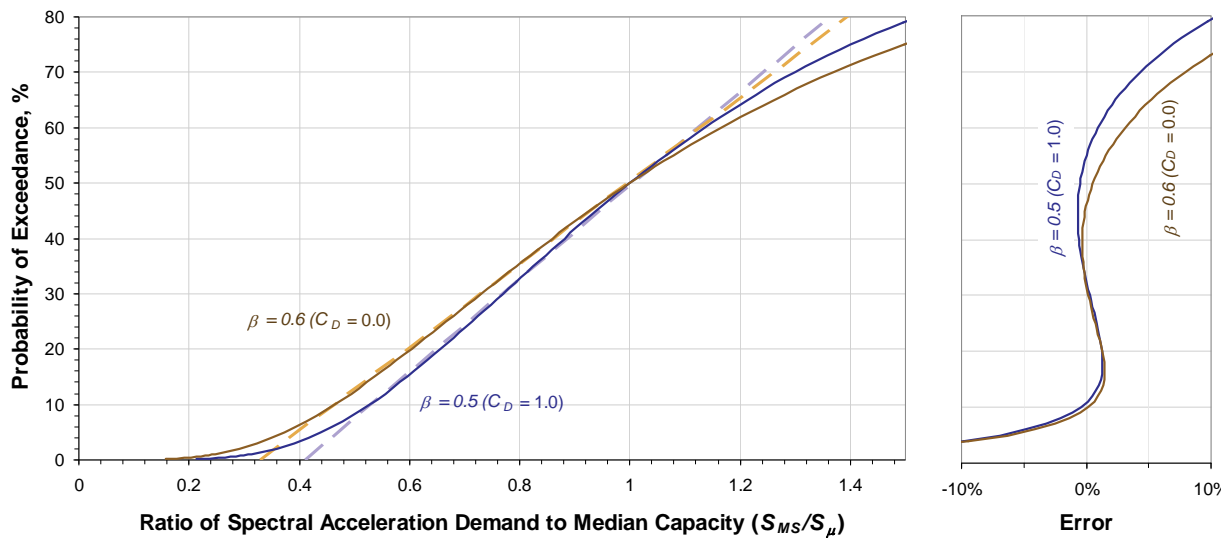

Figure E-26 Lognormal distribution for standard deviations, $\beta = 0.5$ and 0.6 , for ratio of spectral acceleration demand to mean spectral acceleration capacity, over range of probabilities of exceedance, with linear fit (left) and the error (% difference) relative to the linear fit (right).

E.5.6 Retrofit Analyses

For the building models representing the range of potential existing weak-story buildings under consideration, new elements were modeled to represent adding new strength to the first story as retrofitted. As discussed in the following section, the retrofit strength was varied in discrete increments to discover the right amount of strength to add given the characteristics (A_U , A_W , and C_D) of the existing structure. For each retrofit strength increment, the form of the backbone curve for the new elements was set with constant yield and ultimate drift values of 1% and 5%, respectively, and constant ratio of yield-to-ultimate strength of 1.33. The backbone curve is illustrated in Figure E-27 for various strength increments relative to the upper-story shear strength, V_U . The hysteretic behavior of the retrofit elements is full-loop as illustrated in Figure E-28. This backbone curve form is deemed to represent retrofits comprising ductile steel moment resisting frames that may be commonly used in the structures considered. Retrofits comprising structural wood panels are also considered, as described in Section E.5.9, and the form and hysteretic backbone curve for those analyses is based on the wood structural panel backbone curves in the table of commonly used sheathing materials.

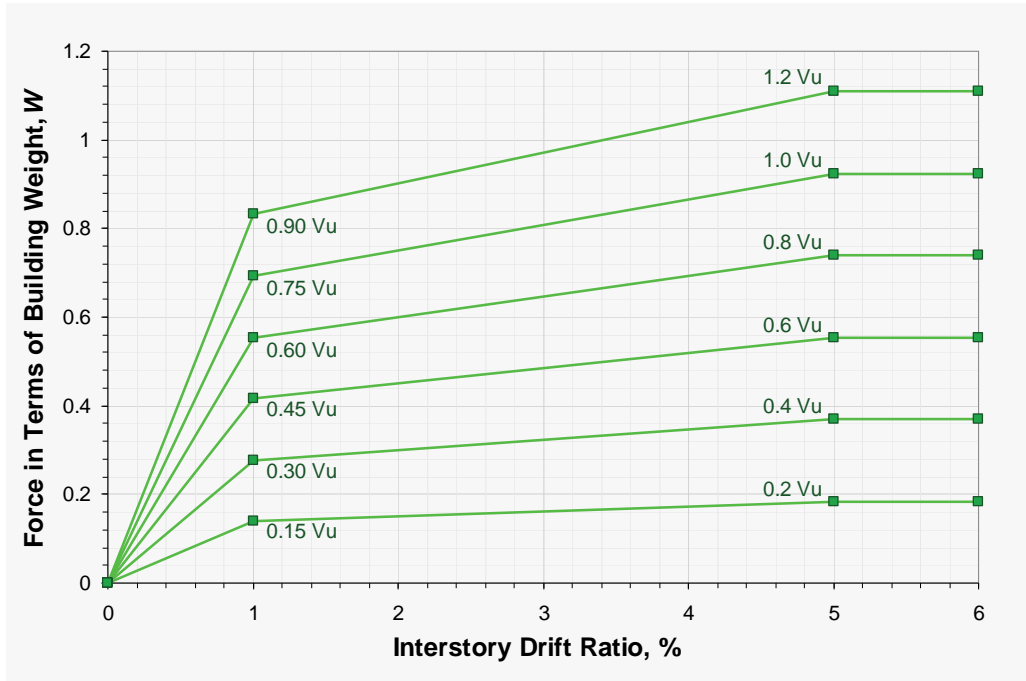

Figure E-27 Retrofit backbone curves for various strength increments relative to the upper-story shear strength, V_u .

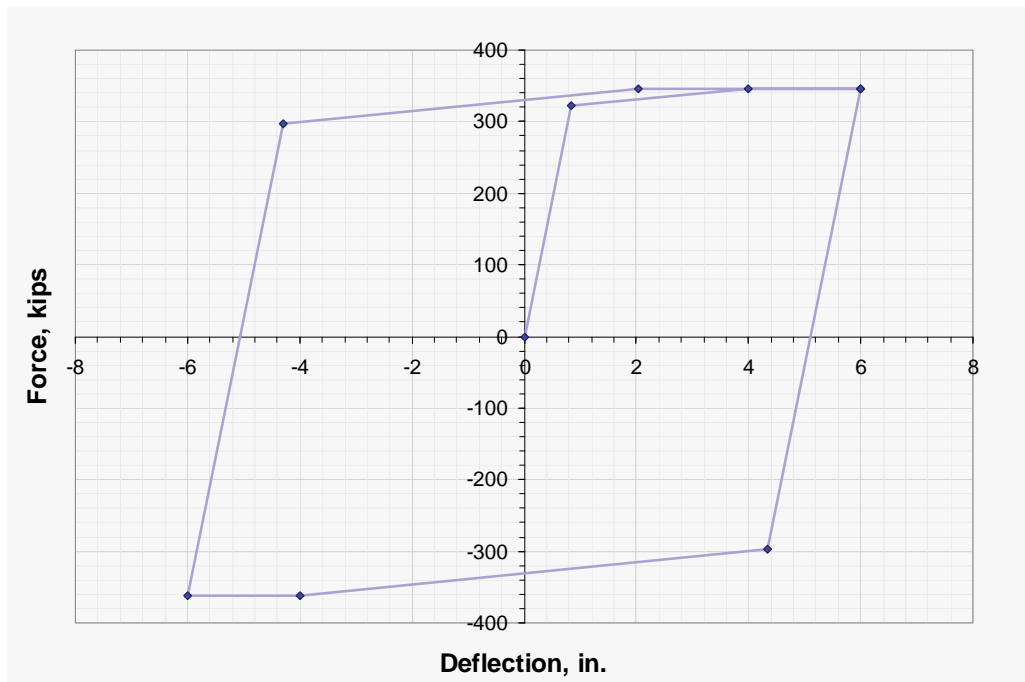

Figure E-28 Plot illustrating hysteretic behavior of moment frame retrofit elements.

E.5.7 Effect of First-Story Retrofit

Adding some retrofit strength in the first story of a building with significant weak-story deficiency generally improves expected seismic performance. The improvement attained by adding first-story strength can be quantified in terms of spectral acceleration capacity relative to a set of drift criteria as illustrated in Figure E-29 and Figure E-30, which show that increasing first-story retrofit strength increases spectral capacity to a point. Thus, flowing from the constraint of retrofitting only the first story is a limit on the best achievable or optimal seismic performance. The plots in figures E-29 and E-30 show four levels of strength (A_U), each with three initial weak-story ratios (A_W). Figure E-29 is for buildings with original construction capable of high displacement ($C_D = 1.0$) and Figure E-30 is for buildings with original construction only capable of low displacement ($C_D = 0.0$). It is noteworthy that, with little regard for the value of A_U and unretrofitted value of A_W , the value of A_W after retrofit (i.e., along the horizontal axis) that leads to the largest spectral capacity occurs consistently between 1.2 and 1.3.

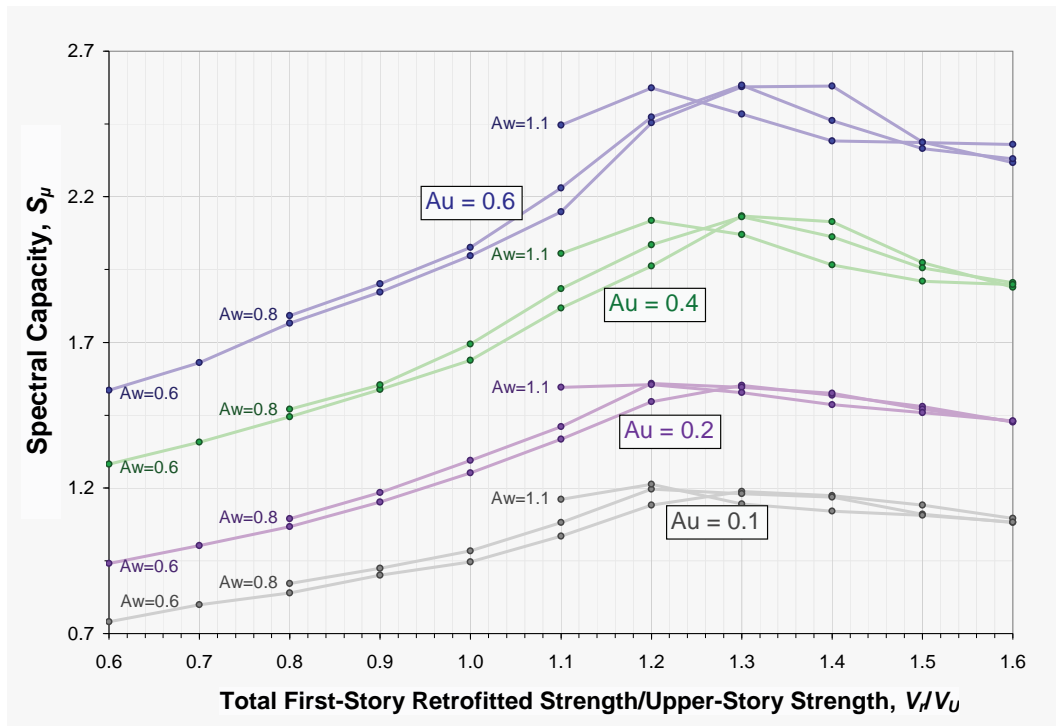

Figure E-29 Plots of spectral acceleration capacity (spectral capacity) as a function of total first-story retrofitted strength, V_r , divided by upper-story strength, V_U , for four levels of base-normalized upper-story strength, A_U , varying initial pre-retrofit weak-story ratios, A_W , original construction having high-displacement capacity ($C_D = 1.0$), and *Onset of Strength* set of drift limits.

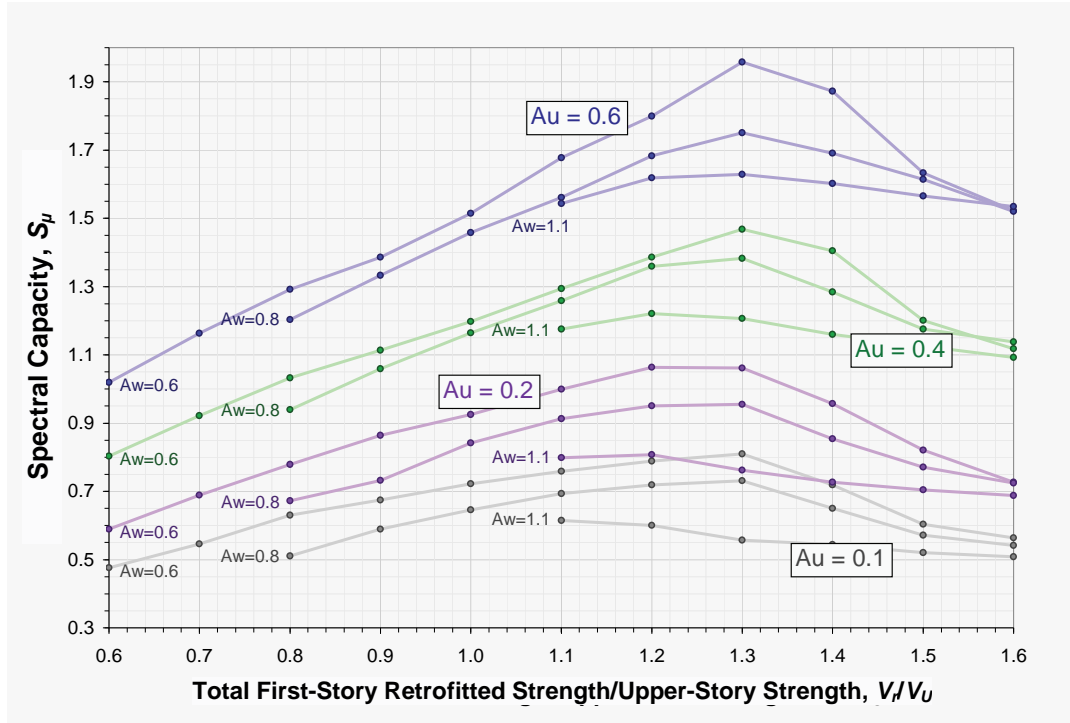

Figure E-30 Plots of spectral acceleration capacity (spectral capacity) as a function of total first-story retrofitted strength, V_r , divided by upper-story strength, V_U , for four levels of base-normalized upper-story strength, A_U , varying initial pre-retrofit weak-story ratios, A_W , original construction having low-displacement capacity ($C_D = 0.0$), and *Onset of Strength* set of drift limits.

The performance-optimal strength of the retrofitted first-story to upper-story strength ratio (termed weak-story ratio) was either 1.2 or 1.3 for 16 of 18 conditions examined. Thus, it seems reasonable to create a nearly-constant linear approximation of the optimal retrofit strength that is close to 1.25 irrespective of weak-story ratio. Plots of the analytical results and linear fit approximation (an equation used in Chapter 6) are shown in Figure E-31.

The retrofit strength equations in Chapter 6 allow for the range of retrofit scenarios that limit the drift in both the first and upper stories to acceptable levels. In many cases, a building with a weak-story vulnerability can be retrofitted to a performance level meeting *Onset of Strength Loss* drift limits at the Maximum Considered Earthquake (MCE) for the selected drift limit probability of exceedance. This condition is discussed in Section 6.2.2 and illustrated in Figure 6-2. The strength of the upper stories is the key to whether this condition can be met. The equations in Chapter 6 are meant to estimate the strength of the first-story at which this condition might be expected.

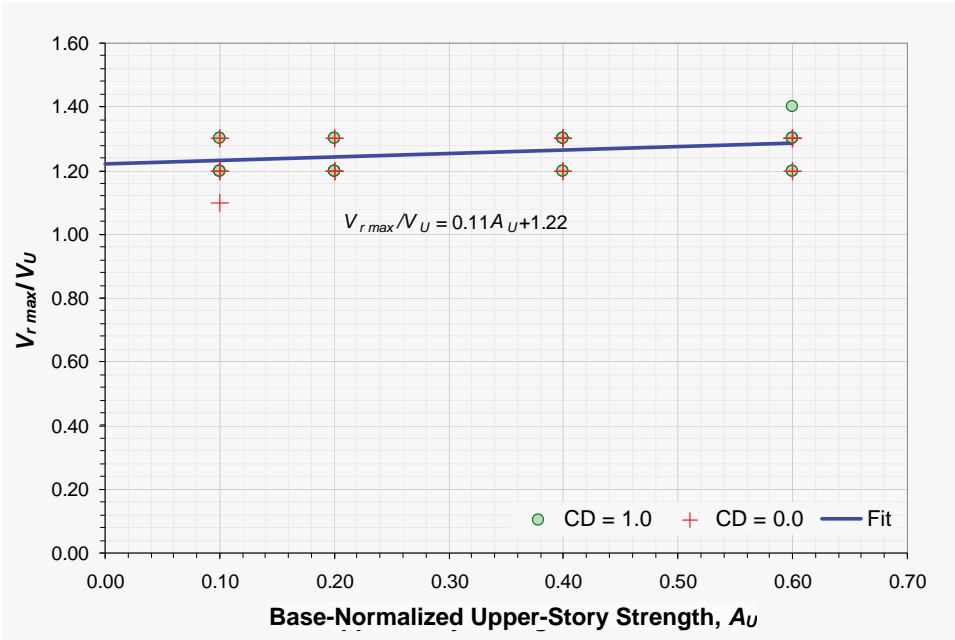

Figure E-31 Plot of maximum strength of total retrofitted first-story, $V_{r,max}$, divided by upper-story strength, V_U , as a function of base-normalized upper-story strength, along with a plot of a linear-fit equation.

E.5.8 Estimating the Minimum Retrofit for Achieving Desired Performance

As discussed in the previous section, a weak-story building may have upper-story strength that is sufficient for a first-story retrofit to achieve the desired seismic performance; i.e., one may not need to retrofit to the point that yields the peak spectral capacity. The minimum target strength of the retrofitted first-story would lead to a spectral capacity (for the specified drift criteria and POE) that is equal to the spectral demand, S_{MS} . In this section, the evaluation equations are manipulated to derive an estimate of the minimum retrofitted strength of the first-story that leads to the desired spectral capacity.

The evaluation equation in Chapter 5 has the general form:

$$S_c = \alpha_{POE} (\alpha_U + \alpha_W A_{W,x}) (1 - 0.5C_T) Q_s A_{U,x}^{\gamma_U} \quad (E-8)$$

where the coefficients α_U , α_W , and γ_U are computed to minimize the error of the fit to the analytical results. Equation E-8 can be rewritten for strength degradation ratios, C_D , of one and zero as:

$$S_{c1} = X_1 A_W + X_2 \text{ for } C_D = 1.0, \text{ and} \quad (E-9)$$

$$S_{c0} = Y_1 A_W + Y_2 \text{ for } C_D = 0.0. \quad (E-10)$$

where:

$$X_0 = \alpha_{POE,1} A_U^{0.48} Q_s (1 - 0.5C_T) \quad (E-11)$$

$$X_1 = 2.24X_0, \text{ and } X_2 = 0.525X_0. \quad (E-12)$$

$$Y_0 = \alpha_{POE,0} A_U^{0.6} Q_s (1 - 0.5C_T) \quad (E-13)$$

$$Y_1 = 1.59Y_0, \text{ and } Y_2 = 0.122Y_0 \quad (E-14)$$

As discussed in previous sections, a cubic model is deemed appropriate for interpolating for intermediate values of C_D , so the final relation for spectral capacity becomes:

$$S_c = C_D^3 (X_1 A_W + X_2) + (1 - C_D^3) (Y_1 A_W + Y_2) \quad (E-15)$$

Substituting S_{MS} for S_c in Equation E-15 and solving for A_W leads to an estimate of the strength ratio, A_W , that achieves the desired seismic performance:

$$A_W = \frac{S_{MS} - X_2 C_D^3 - Y_2 (1 - C_D^3)}{X_1 C_D^3 + Y_1 (1 - C_D^3)} \quad (E-16)$$

The strength of the retrofitted first story follows as $V_r = A_W V_U$, where V_U is the limiting strength of the upper stories.

In the above derivation, it is implied that A_W changes independently of the other coefficients, particularly C_T and C_D ; this is not true in general. In order to change A_W , one must add strength to the first-story, and doing so will almost always affect the torsion coefficient, C_T and will often affect the strength degradation ratio, C_D . Thus, the value of A_W recovered from Equation E-16 will not be the exact value that causes the spectral capacity, S_c to equal the spectral acceleration demand, S_{MS} . In fact, Equation E-16 will over-predict the amount of retrofit strength needed. It provides an estimate of the target retrofit strength, and the estimate converges with iteration. Thus, Chapter 6 refers to these retrofit strength values as estimates and calls for confirmation of the final retrofit design using the evaluation equations of Chapter 5.

E.5.9 Wood-sheathed walls versus Moment Frame Retrofit

Two types of load-drift curves were considered for retrofit elements: a full hysteretic loop that might come from a moment frame and wood-sheathed walls that would have behavior similar to the high-displacement capacity material form. The method used to model the plywood retrofit scenarios

mimics the modeling of the high-displacement capacity material form (see Section E.2.4).

The optimal retrofit strength is determined using the moment frame assumption, and then the performance of the structure with plywood retrofit is compared to that with the moment frame retrofit. Typically, the difference in performance is small; Figure E-32 illustrates what might be the largest discrepancy. Thus, the *Guidelines* make no distinction between using plywood or moment frames as retrofitting elements.

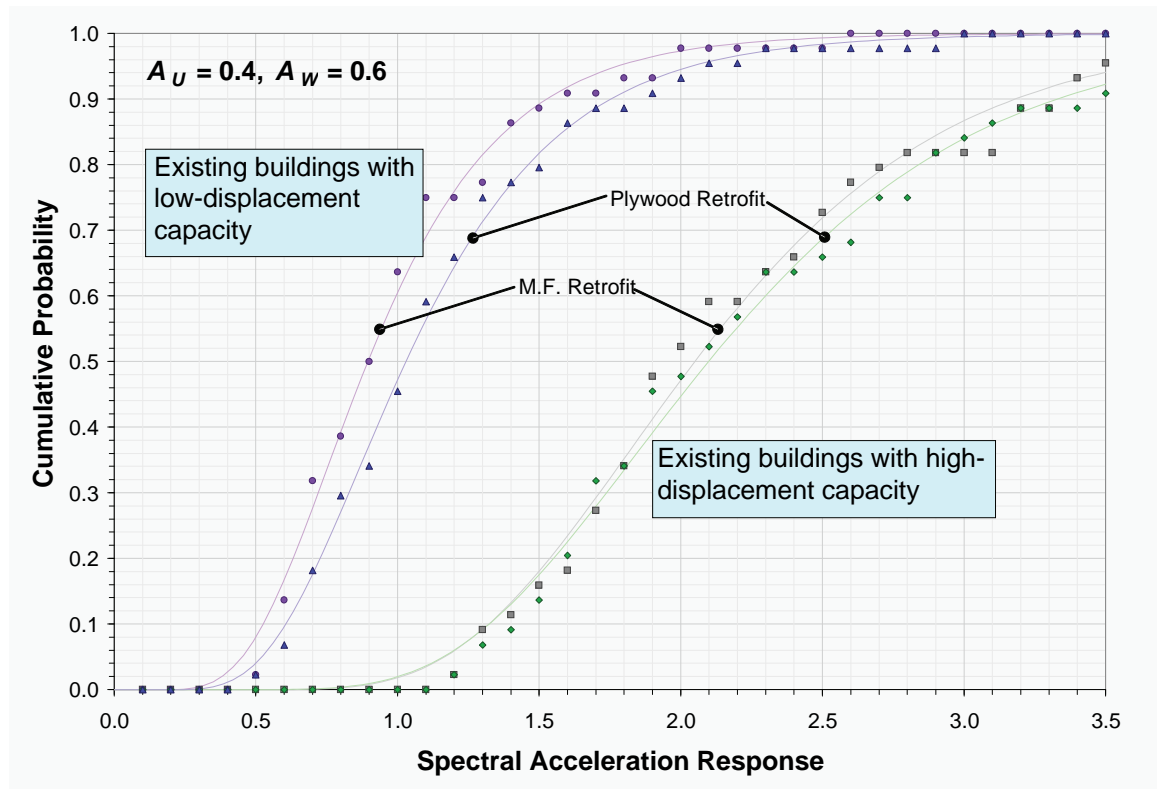

Figure E-32 Plots comparing retrofit performance for moment frame (M.F.) versus plywood wall retrofit, as a function of earthquake shaking intensity, for base-normalized upper-story strength, $A_U = 0.4$, and weak-story ratio, $A_W = 0.6$.

It is somewhat surprising that the plywood retrofit behaves better in some cases than the moment frame retrofit, and further study into this comparison is warranted. It should be noted that the plywood retrofit does not give better results in every case, but in those cases the performance is essentially equivalent. The reason may be that the moment frame is significantly softer than the plywood elastically, so the structure must move farther before the moment frame reaches its peak strength. For the low-displacement materials, the implication is that the existing materials would have lost strength by that point.

E.5.10 First-Story Height

The seismic performance of a weak-story building will depend on the height of the first story. Given two buildings that are identical with the exception of different first-story heights, the building with the shorter first story will have worse seismic performance. A small analytical study was done to verify and explore this effect. For this study, a simple building model was selected ($A_U = 0.4$, $A_W = 0.6$) for each material form, with and without optimal retrofit: four models, total. The first-story height was varied from 15 inches (1'-3") to 200 inches (16'-8"). The backbone curves were kept *constant* relative to *interstory drift*.

Figure E-33 shows the median spectral acceleration capacity plotted against first-story height for each model. Clearly, the median spectral acceleration capacity increases for increasing first-story height. In Figure E-34, the median spectral acceleration capacity is normalized by dividing the median spectral acceleration capacity for a building of given first-story height by that of the building with 100-inch first-story height. This implies that a linear fit might adequately represent the trend irrespective of retrofit and strength degradation ratio, C_D . Figure E-35 shows the normalized median spectral acceleration capacities with a linear fit based on a first-story height of 100 inches. Chapters 3 and 4 use a similar equation, adjusted slightly to be based on a first-story height of 8 ft.

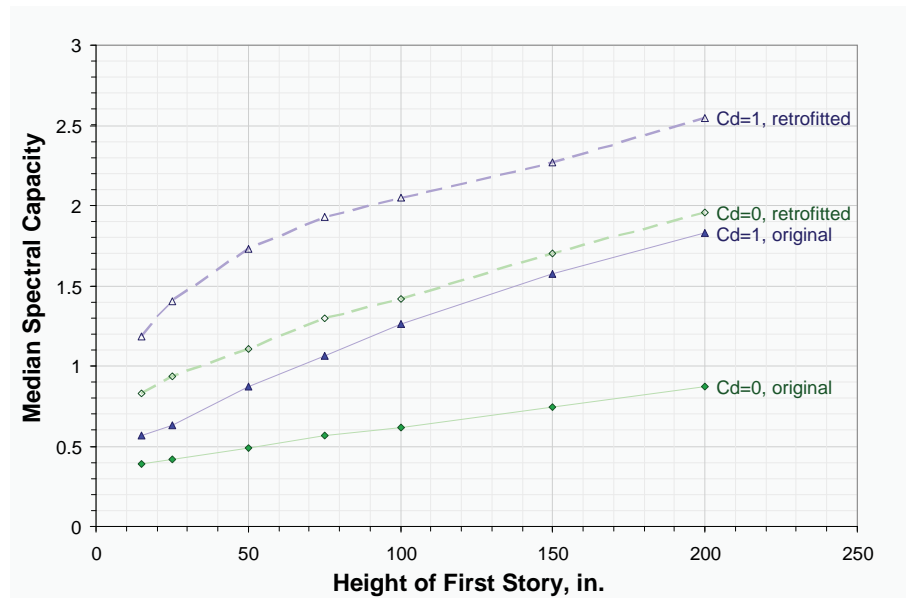

Figure E-33 Plots of median spectral acceleration capacity (spectral capacity) versus first-story height for four building models considered. C_D = strength degradation ratio.

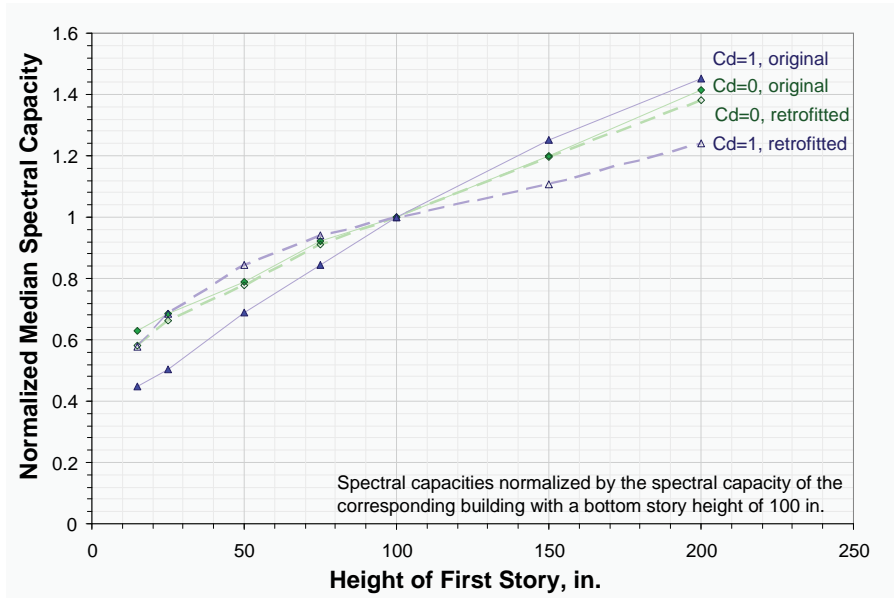

Figure E-34 Plots of normalized median spectral acceleration capacity (spectral capacity) versus first-story height for four buildings considered. Spectral capacity is normalized by dividing spectral capacity at a given height by the spectral capacity of the building with a 100-inch height. C_D = strength degradation ratio.

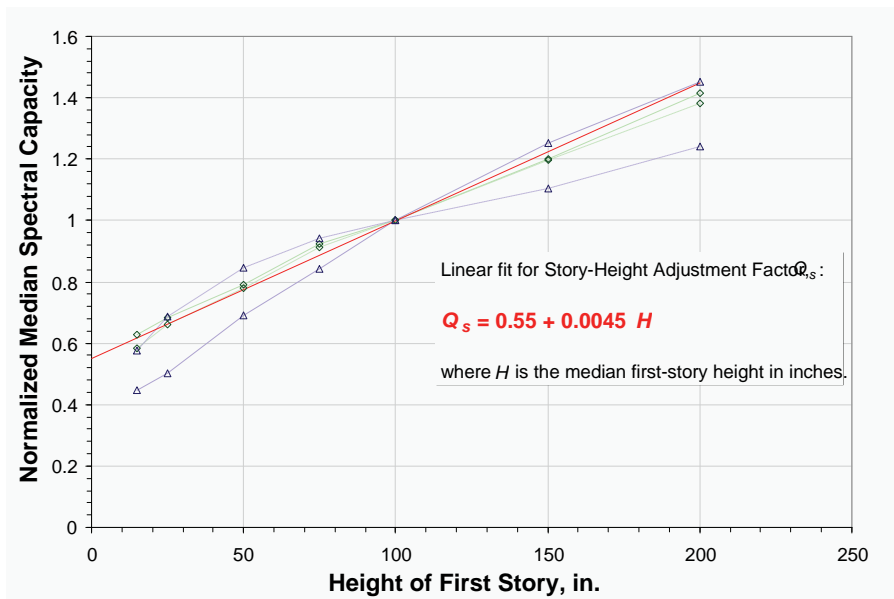

Figure E-35 Plots of normalized median spectral acceleration capacity (spectral capacity) versus first-story height for four buildings considered with linear fit. Spectral capacity is normalized by dividing spectral capacity at a given height by the spectral capacity of the building with a 100-inch height. C_D = strength degradation ratio.

E.6 Torsional Analyses

E.6.1 Discussion on Torsional Behavior

Torsional behavior is distinctly more complicated than translational behavior because the two directions of motion are coupled. Thus, even if the center of strength aligns with the center of mass (the center of the seismic inertial loading), in one direction, the spectral acceleration capacity in that direction will be affected by eccentricity in the other direction. Torsional behavior is also coupled with translational force input. Earthquakes do not deliver torsional moment to the base of the building (assuming the buildings are small), but it is the eccentricity that exists between the centers of strength and mass that causes twisting to occur. Because of these complexities, a comprehensive treatment of torsional behavior would probably require more study. Because a limited treatment of torsion is presented and incorporated into the *Guidelines*, an engineer designing a retrofit should strive to remove torsion in the first story to the extent practical.

E.6.2 Torsion Coefficient, C_T

Torsional vulnerability is treated as another phenomenon that can be parameterized by a coefficient like the other coefficients used in the *Guidelines*. This approach allows simple recommendations, based on the lateral load-drift characteristics of the existing and retrofitted first story.

The center of strength is, by definition, the point at which the application of lateral force causes no rotation. A simplified understanding of the torsional response would be that there is a translational force imparted from the first-story to the upper stories through the center of strength of the first story. As the force is applied, the upper stories apply an inertial reaction through their center of strength, which is often uniform among the upper stories and coincides near the center of mass. This causes a torsional couple. Assuming the upper stories rotate about the first-story center of strength, the torsional resistance stabilizing the upper stories is characterized by the torsional strength of the first story, T_1 , computed in Chapter 4.

The lateral strength of the first story has two orthogonal components; a force vector that will potentially occur during any response-history as the structure reaches its peak strength and yields in the two directions simultaneously. In general, the relationship between the centers of strength at the first story and the upper stories can be characterized as a position vector with two orthogonal components. Torsional moment is defined to be the cross-product of the eccentricity vector and the force vector. Thus, the definition of the Torsional Demand, τ , emerges in Chapter 4.

The natural next step is to divide the torsional demand by the capacity to arrive at the unitless torsion coefficient, C_T .

E.6.3 Modeling

Building models were devised that vary C_T while holding other parameters constant. Values of C_T considered range from 0.0 (no torsion) to 1.0 (unretrofitted) and 1.58 (retrofitted). The following list summarizes the range of other parameters considered:

- Base-normalized upper-story strength, A_U : 0.4;
- Weak-story ratio, A_W : 0.6, 0.8; and
- Both low-displacement capacity (Ld) and high-displacement (Hd) capacity material forms.

Each building model was also re-analyzed with the optimal retrofit strength placed at the original center of strength. This causes the increase in C_T from 1.5 (unretrofitted) to 1.58 (retrofitted) noted above.

The building models for torsion were analyzed with two translational and one rotational degree of freedom on each level. They comprise four lateral bracing systems similar to what was described in detail in Section E.3.2 representing four wall lines. The weight of the entire building was 1 kip, distributed evenly to each of the four levels (0.25 kips per level). The nodes at each level were constrained by a rigid diaphragm assumption.

In general, the value of C_T depends on many factors including the locations of the walls, the relationship of the lateral strength of walls in one direction versus the other, and the distribution of the wall strengths. Also, the torsional moment of inertia depends upon the geometry of the floors. For these analyses, for a given building model, the strength and weak-story ratio in each horizontal direction was equal. In order to increase C_T , the wall line elements in the longitudinal direction on the front façade on the first story was moved toward the back in four increments, and the transverse walls lines were moved in toward the center. Figure E-36 and Figure E-37 illustrate each building model form for the four increments of C_T considered.

E.6.4 Response-History Input

The response-history input for the torsional analyses differs from that of the translational analyses. It was deemed appropriate to simultaneously run the ground-motion records considering both components of motion. However, since the orientation of the records should be random, the building models

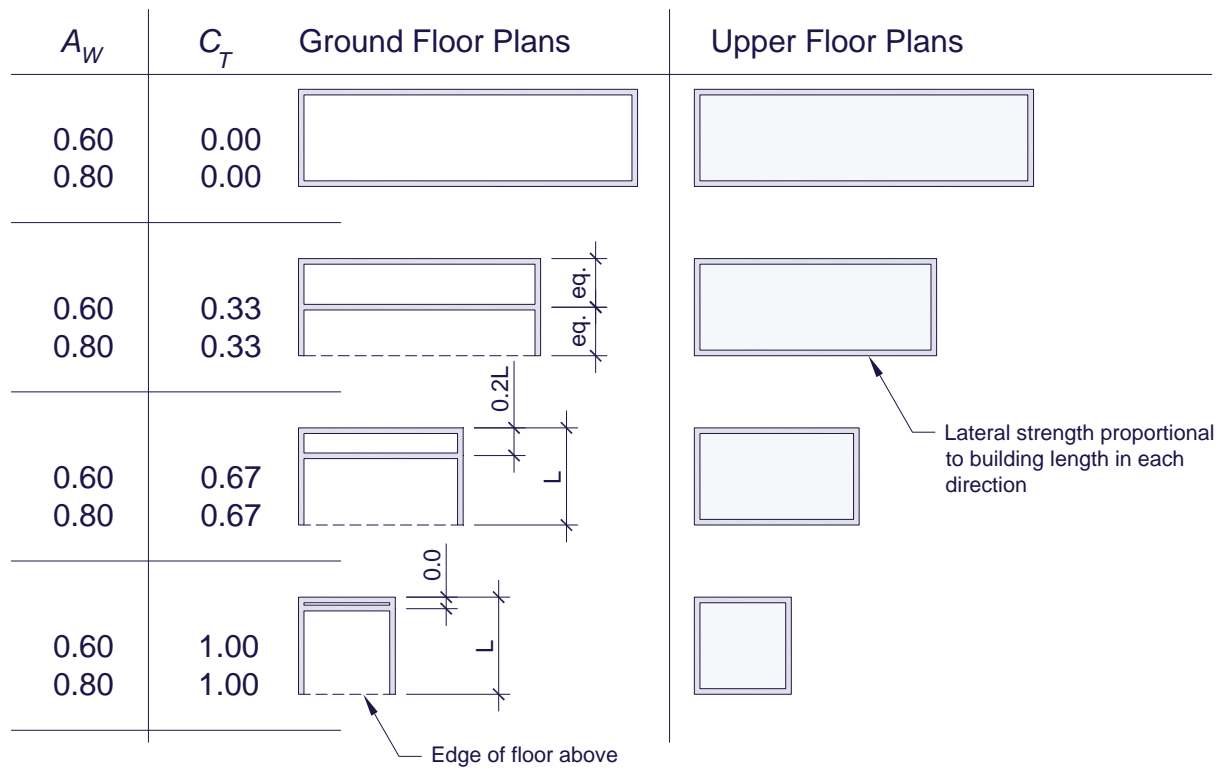

Figure E-36 Schematic illustration of floor plans and values of weak-story ratio, A_W , used in Perform 3D models of unretrofitted buildings for various torsion coefficients, C_T .

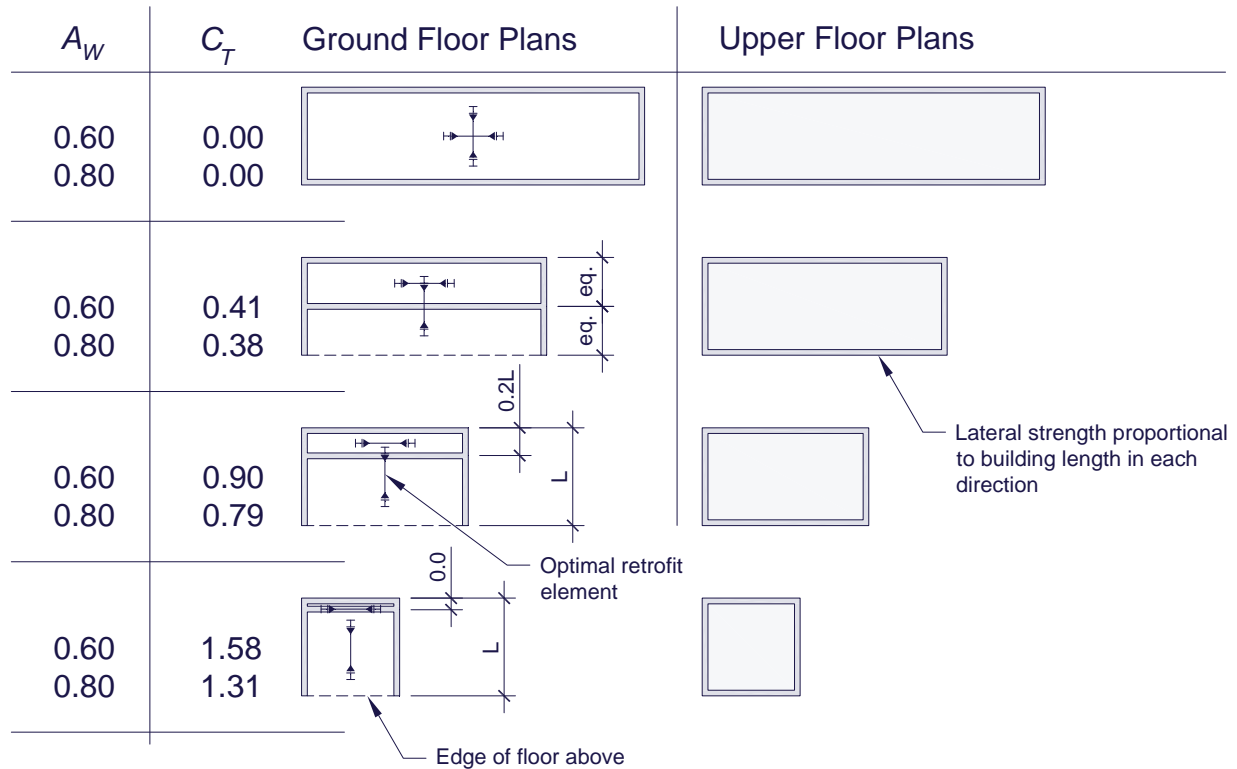

Figure E-37 Schematic illustration of floor plans and values of weak-story ratio, A_W , used in Perform 3D models of retrofitted buildings for various torsion coefficients, C_T .

were analyzed once with an orientation angle of zero degrees and re-analyzed with an orientation angle of 90 degrees. Thus, the total number of records considered in the incremental dynamic analysis (IDA) remained at 44.

E.6.5 Assessing the Effect of Torsion

Analyzing the results of the IDA on the building models for torsion, a correlation was found between increasing C_T and reduction in spectral acceleration capacity for the *Onset of Strength Loss* set of drift criteria, considering the longitudinal direction of the building models, i.e., the direction *perpendicular* to the movement of the front façade wall line. The correlation is characterized fairly well with a simple linear approximation as illustrated in Figure E-38.

The results, considering drift in the transverse direction, also showed a correlation between increasing C_T and reduction in spectral capacity. A somewhat different trend is illustrated in Figure E-39. The reduction starts more steeply and appears to level off at C_T near 1.0.

The load-drift behavior in each direction is exactly the same if torsion is ignored. Because the time-histories are run in two orthogonal orientations as separate analyses, the translational demand on the building is the same in

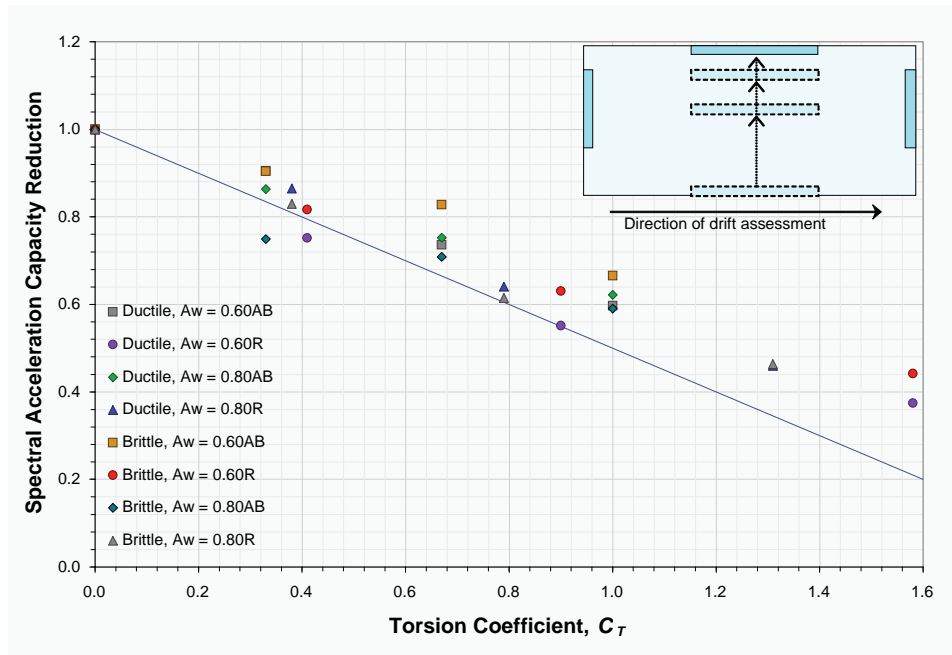

Figure E-38 Plots of spectral acceleration capacity reduction versus torsion coefficient, C_T , for the *Onset of Strength Loss* set of drift criteria, considering the longitudinal direction for various values of weak-story ratio, A_w . “AB” indicates unretrofitted model; “R” indicates model with optimal retrofit.

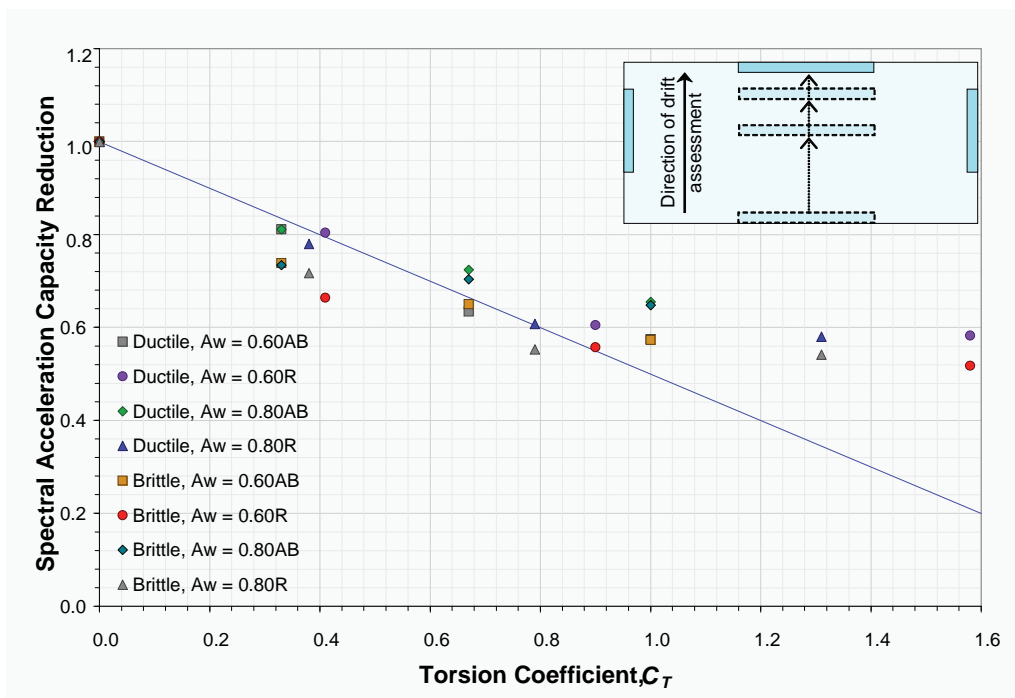

Figure E-39 Plots of spectral acceleration capacity reduction versus C_T , for the *Onset of Strength Loss* set of drift criteria, considering the transverse direction for various values of weak-story ratio, A_w . “AB” indicates expected model; “R” indicates model with optimal retrofit.

each direction. Thus, there appears to be an interesting effect wherein the transverse walls are taxed more heavily than the longitudinal walls due to the torsional demand caused by the forces acting longitudinally. This is because the greatest resistance to rotation comes from the walls the greatest distance from the center of rotation. Thus, for the building plan shown, the transverse walls will carry more of the torsional forces.

E.6.6 Simplified Torsion Coefficient, C_{Ts}

The simplified torsion coefficient, C_{Ts} is derived from the torsion coefficient, C_T by making certain assumptions that are considered appropriate in the context of the simplified evaluation in Chapter 3 of the *Guidelines*. The torsional coefficient, C_T is the ratio of torsional pseudo-demand, τ , to torsional strength of first-story, T_1 , as defined in Chapter 4:

$$C_T = \frac{\tau}{T} ; \text{ need not be greater than 1.4} \quad (\text{E-17})$$

As described in Section 4.6.8, the torsional demand, τ , is calculated by multiplying the translational strength of the ground story by the eccentricity (as illustrated in Figure 4-14). It is given by:

$$\tau = e_x V_{1,y} + e_y V_{1,x} \quad (\text{E-18})$$

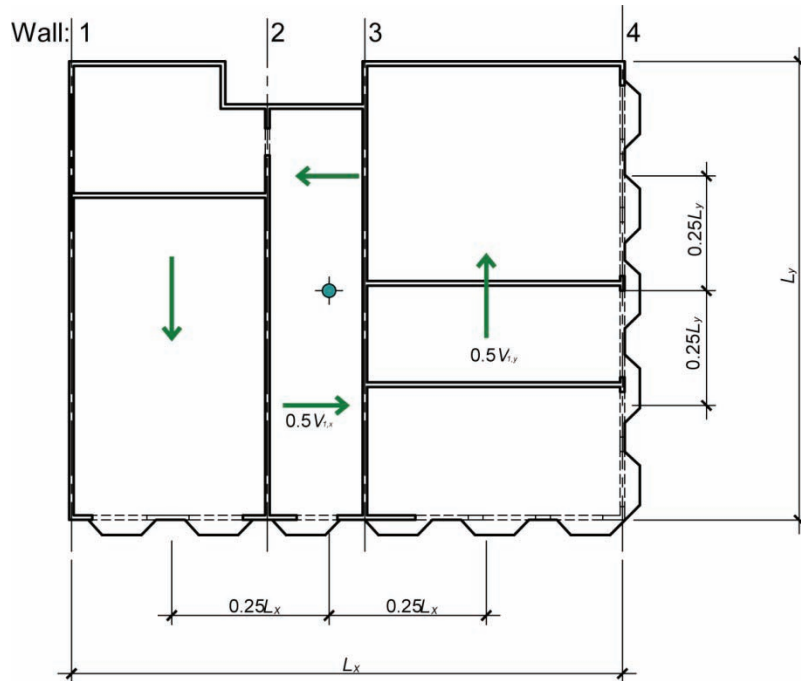

Figure E-40 Illustration of the simplified torsional strength, T_s .

Computing the torsional strength of the first story, T_1 , in accordance with Chapter 4 is not trivial. Therefore, a simplifying assumption is made to estimate the torsional strength, as illustrated in Figure E-40. The torsional strength is computed by applying a twist about the center of strength, and computing the corresponding torque. In this simplified approach, the first story is twisted about the geometrical centroid of the floors above, assuming that the resultant of one-half the wall shear in each direction will act through a point located one-quarter of the building dimension away from the center. With this assumption, the torsional strength becomes:

$$T_s = V_y \left(\frac{L_x}{4} \right) + V_x \left(\frac{L_y}{4} \right) \quad (\text{E-19})$$

A further assumption is made, that $V_x \approx V_y$; Equation E-18 and Equation E-19 become:

$$\tau = V(e_x + e_y) \quad (\text{E-20})$$

$$T_s = \frac{V}{4}(L_x + L_y) \quad (\text{E-21})$$

Thus, the simplified torsion coefficient, C_{Ts} , as used in Chapter 3, becomes:

$$C_{Ts} = 4 \left(\frac{e_x + e_y}{L_x + L_y} \right) \quad (\text{E-22})$$

Appendix F

Validation of Analysis Methods

F.1 Purpose

Early on in the *Guidelines* developmental effort, members of the project team performed preliminary analytical work to verify the concept of the “Relative Strength Method.” The results of that effort are documented in an internal ATC report, “Task 2: Detailed Analytical Verification.” This analysis is referred to herein as the *Task 2 Analysis*. The conclusions of that work support the validity of the concept. The analytical framework described in Appendix E of the *Guidelines* broadened the scope of results by considering a large number of simple idealized buildings. The analysis work described in Appendix E is referred to herein as the *Broad-Scope Analysis*.

The purpose of this appendix is to compare and contrast the results of these two sets of analysis to validate the analysis methods used in Appendix E of the *Guidelines*. The details of each body of work are sufficiently described elsewhere; this appendix supplements those details from the perspective of comparison.

F.2 The Building Under Consideration

The *Task 2 Analysis* focused on a rectangular, wood-framed, three-story apartment building that had been studied previously as part of the CUREE-Caltech Wood-Frame Project (Reitherman et al., 2003), which was carried out by California Universities for Research in Earthquake Engineering (now the Consortium of Universities for Research in Earthquake Engineering) and the California Institute of Technology, with funding from FEMA. This building is referred to herein as the *CUREE Apartment Building*. The building (Figure F-1) is assumed to have been constructed prior to 1970 in Northern or Southern California, designed according to the 1964 edition of the *Uniform Building Code* (ICBO, 1964) and ‘engineered’ to a minimal extent. The floor-to-floor height of the apartment building is about 9’-0”. The total dead load, W , is about 348.5 kips.

The *Task 2 Analysis* focused mainly on response in the long (east-west) direction, which has a greater weak-story character than in the north-south direction. Torsion was eliminated from the analysis because the pushover curves for the east-west direction were not significantly affected by

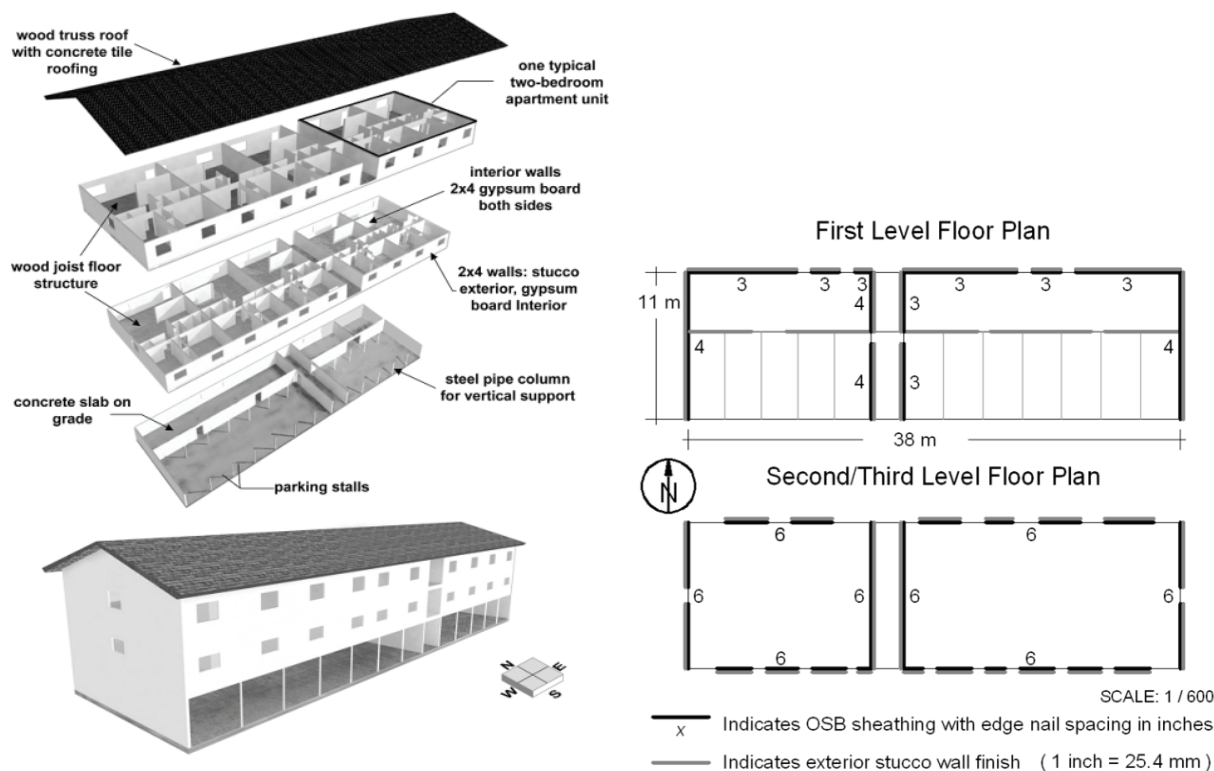

Figure F-1 CUREE Apartment Building used in ATC-71-1 Task 2 Analysis (from Christovasilis et al., 2009).

torsion. Following is a list of the building's characteristics in the east-west direction in terms of the *Guidelines* coefficients:

1. First-story strength, $V_1 = 0.452W$
2. Second-story strength, $V_2 = 0.6W$
3. Base-normalized upper-story strength, $A_U = 0.6$
4. Weak-story ratio, $A_W = 0.75$
5. Strength degradation ratio, $C_D = 0.66$

F.3 Differences in Scope of Analysis

Whereas the *Task 2 Analysis* focused in detail on one particular building, the *Guidelines* cover a broad scope of structures. It was deemed appropriate that the *Broad-Scope Analysis* sufficiently cover the whole range of buildings that could potentially be covered by the requirements of the *Guidelines*. In the following subsections, various characteristics of the buildings under consideration are described, with discussion about how the *Broad-Scope* and *Task 2 Analyses* differ.

F.3.1 Number of Stories

Whereas the *CUREE Apartment Building* is three stories tall, many buildings covered by the *Guidelines* have four stories. For the *Broad-Scope Analysis*, it was assumed that the four-story structure should be modeled and that the results should be applicable to the three-story structure, if the results were normalized by the total building mass.

F.3.2 Sheathing Assemblies

The sheathing materials in the *CUREE Apartment Building* include both structural wood sheathing and finish materials. This leads to load-deflection curves that are a composite of high- and low-deformation capacity materials. In the parlance of the *Guidelines*, the strength degradation ratio, C_D , is between 0.0 and 1.0. For the *Broad-Scope Analysis*, the permutations of building models considered the two extreme possible strength degradation ratios (0.0 and 1.0), but nothing in between. This was done for the practical purpose of limiting the analysis work to what was possible to achieve within the budgetary and time limitations of the project. It is assumed that having the results for the extreme strength degradation ratios, one can adequately estimate for intermediate ratios using linear interpolation.

F.4 Differences in Analytical Methods

The two analysis efforts were done by different teams with distinct perspectives and approaches related to the work involved. The following subsections describe some of the differences related to the analytical methods.

F.4.1 Software

The *Task 2 Analysis* team used SAWS (Seismic Analysis of Wood-frame Structures) computer software (Folz and Filiatrault, 2004a,b) to perform the analyses. SAWS features sophisticated hysteretic behavior tailored for modeling wood-framed structures. One key aspect of this behavior is to dissipate energy at low displacements as opposed to having a range of elastic strength (see Figure F-2). SAWS can also model hysteretic behavior characteristic of ductile moment frames with full hysteretic loops. The backbone for these elements is bilinear with an elastic range and post-yield range with strain hardening (see Figure F-3).

The *Broad-Scope Analysis* was done using CSI (2006) Perform-3D software, a general purpose nonlinear structural analysis application. Because Perform-3D does not have a built-in wood-frame wall element, as SAWS

does, non-linear “concrete” material (a zero-tension material with tri-linear and strength-loss

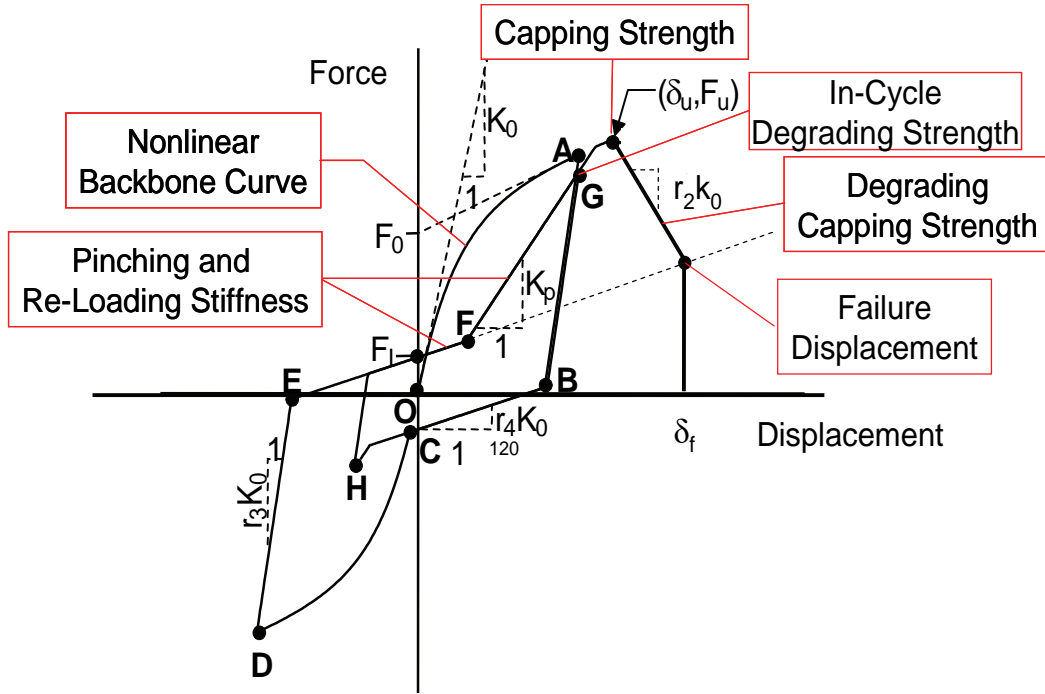

Figure F-2 Hysteretic behavior of wood-framed elements in SAWS (after Folz and Filiatrault (2004a,b). Parameters shown are defined in Folz and Filiatrault (2004a,b).

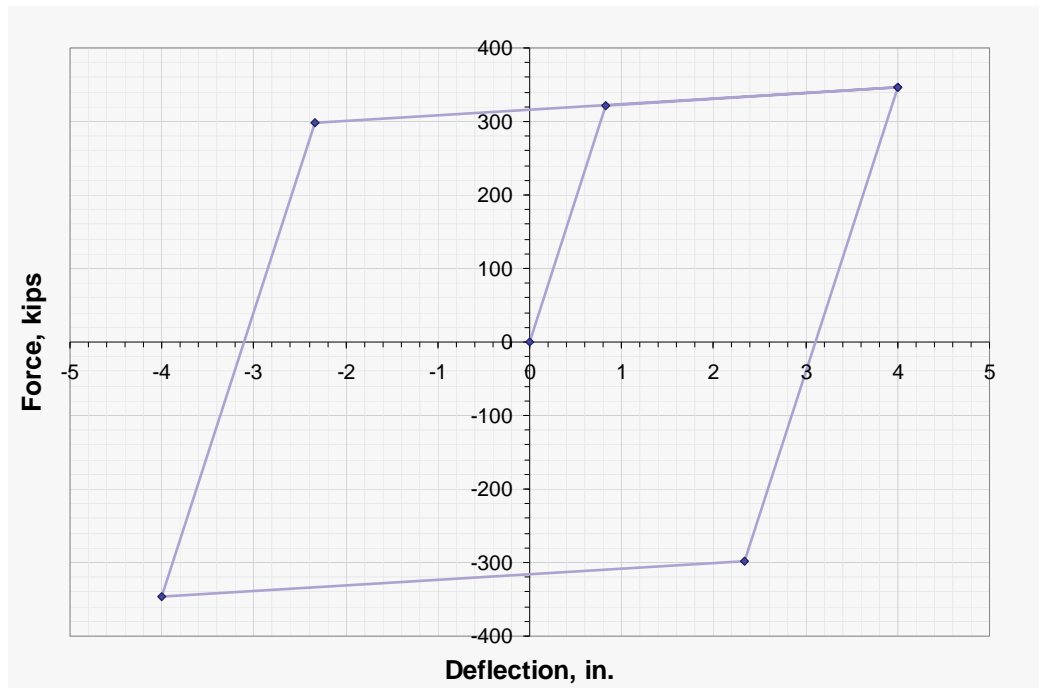

Figure F-3 Hysteretic behavior of moment frame elements in SAWS.

backbone options) was modeled as cross-struts calibrated to emulate the expected hysteretic behavior of wood. Each floor level had four compression-only cross-struts, with staggered yield points (see Figure F-4 and Figure F-5). The ductile moment frames were modeled using inelastic diagonal bar elements with a trilinear backbone curve (see Figure F-6).

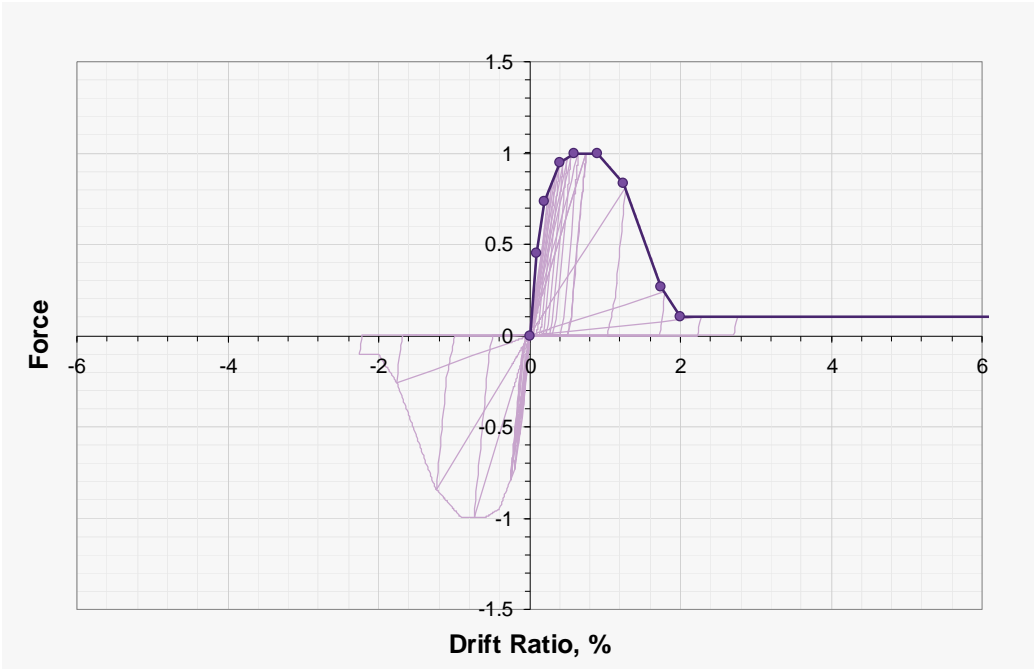

Figure F-4 Hysteretic behavior of elements emulating wood-frame walls in Perform-3D, where the strength degradation ratio, $CD = 0.0$.

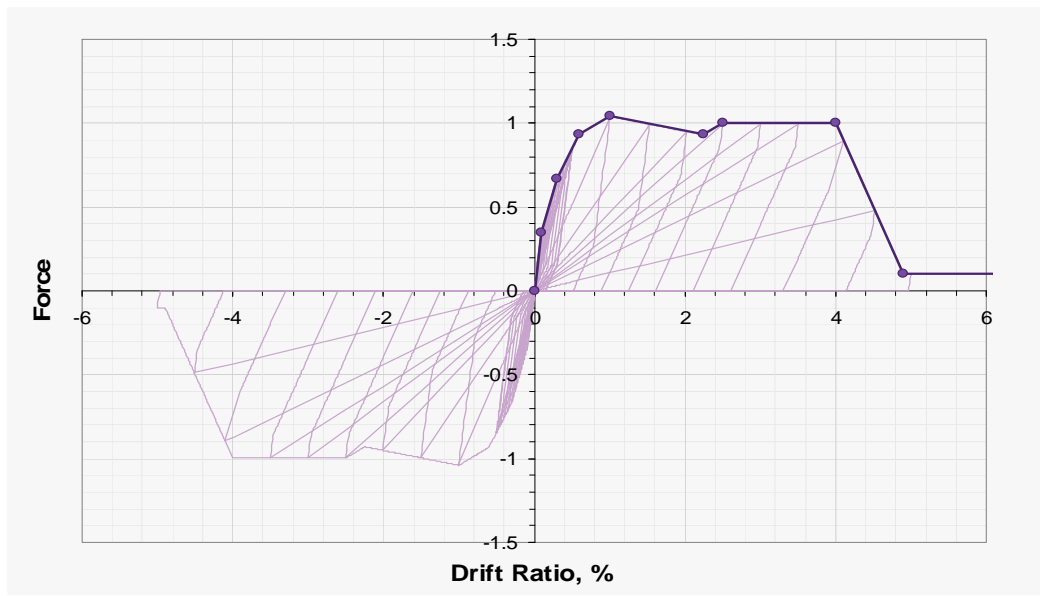

Figure F-5 Hysteretic behavior of elements emulating wood-frame walls in Perform-3D, where the strength degradation ratio, $CD = 1.0$.

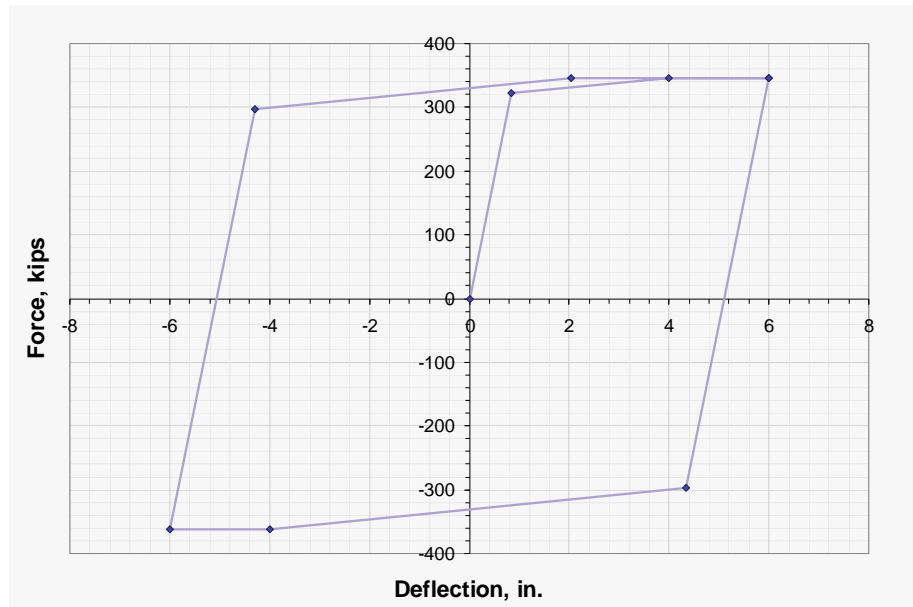

Figure F-6 Hysteretic behavior elements emulating ductile moment frames in Perform-3D.

F.4.2 Viscous Damping

The *Task 2 Analysis* included Rayleigh (also known as alpha-M, beta-K) viscous damping. This models damping as a constant velocity damping matrix composed of adding particular fractions of the mass and elastic stiffness matrices. The user inputs a damping ratio for the first two modes of vibration, and the software determines the corresponding coefficients for each matrix. In the *Task 2 Analysis*, 1% damping was chosen for the first two modes; damping for the third mode was computed to be 1.28% for the existing structure and 1.24% for the retrofitted.

In the *Broad-Scope Analysis*, viscous damping was modeled using modal damping. In this approach the damping matrix was computed by combining the mass matrix in a special way. One can specify the damping ratio to be constant for all modes, as opposed to Rayleigh damping, where only the damping is constant for two modes but varies for all others. In the *Broad-Scope Analysis*, 2% modal damping was used for all modes.

It was decided to not re-run the analysis with a damping model to match the *Task 2 Analysis*. As is shown in later sections of this appendix, the results appear unaffected by the choice between these two damping models when other aspects of the models are constructed to match.

F.4.3 Backbone of Increasing Retrofit

In the *Task 2 Analysis*, the elastic and strain hardening stiffnesses were held constant irrespective of retrofit strength. The elastic stiffness corresponded to four W14×90 cantilevered columns, and the post yield stiffness was set at 0.02 times the elastic stiffness. The base yield strength, V_y , was set at 322 kips ($0.92W$ or $1.6V_2$). There was no plateau modeled. The range of yield strengths modeled varied between $0.2V_y$ ($0.12W$) and $1.2V_y$ ($0.7W$), as shown in Figure F-7.

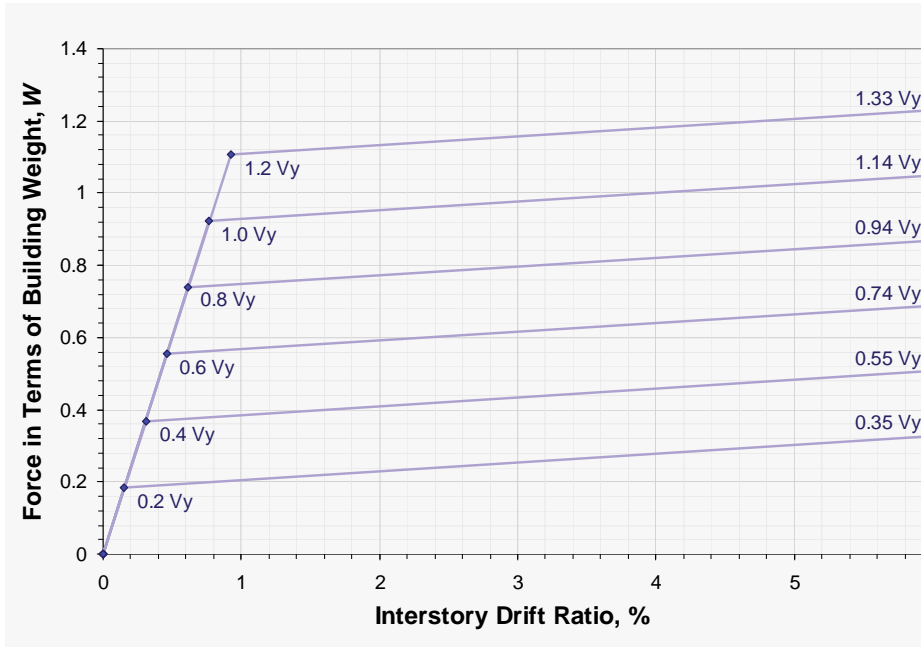

Figure F-7 Backbone curves for varying retrofits modeled in the *Task 2 Analysis*.

In the *Broad-Scope Analysis*, the drift ratio at yield and ultimate plateau were held constant at 1% and 5%, respectively. The ratio of yield to ultimate strength was held constant at 0.75, and the elastic and hardening stiffnesses vary. In the *Task 2 Analysis*, retrofit strength was keyed at the yield strength of the retrofit, but in the *Broad-Scope Analysis*, the retrofit strength was keyed off of the ultimate strength, V_u . Figure F-8 shows the range of retrofit strengths in the *Task 2 Analysis*.

Figure F-9 compares backbone curves for three selected retrofit strengths for each analysis. It is clear that there is a significant distinction between the two analysis approaches, both in terms of what is a reasonable model of the retrofit (constant stiffness versus constant yield drift and ratio V_u/V_y) and how it is described (based on V_y versus V_u). One must be careful when comparing the results that the terms are defined on the same basis.

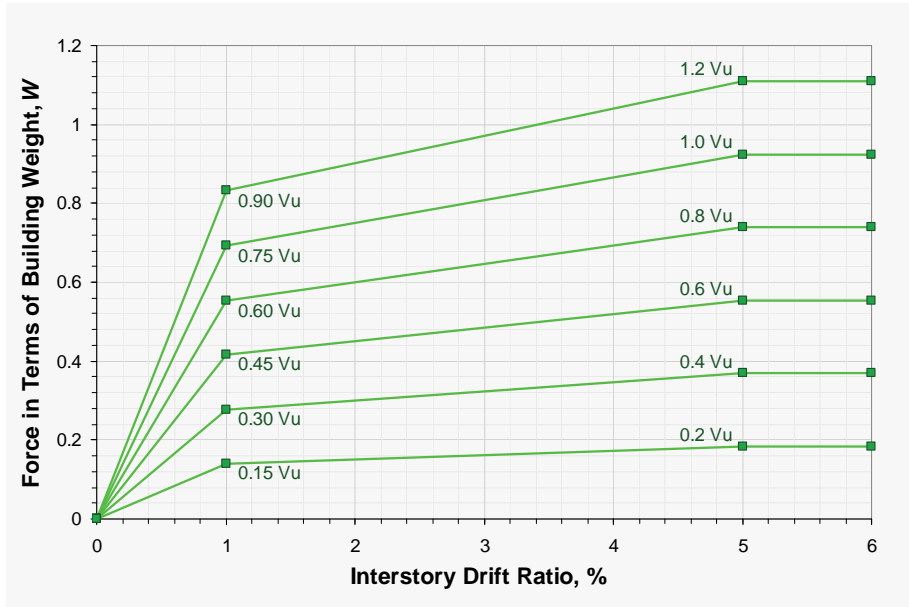

Figure F-8 Backbone curves for varying retrofits modeled in the *Broad-Scope Analysis*.

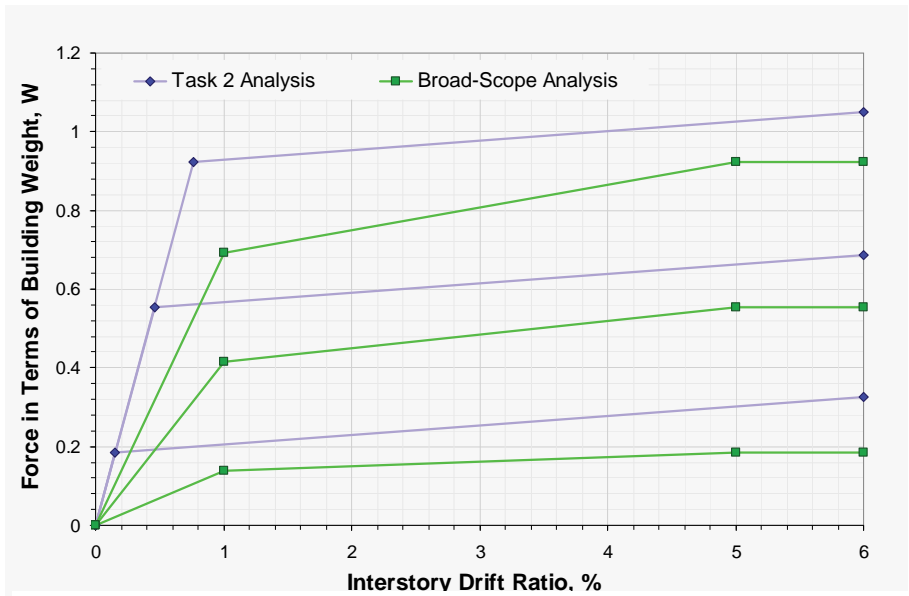

Figure F-9 Comparison of selected backbone curves for varying retrofits modeled.

F.5 Comparison of Results

As noted above there were many differences between the two analysis approaches that may lead to different results. It was decided to build a model in Perform-3D that matches the properties of the building as documented in the *Task 2* report but using the modeling methods of the *Broad-Scope Analysis*. Thus, cross-strut and retrofit elements were calibrated to match the

backbone curves shown in the *Task 2 Report*. The number of stories was set at three. The damping model was left unchanged. The Incremental Dynamic Analysis (IDA) was re-run using the suite of 44 acceleration records, and the median earthquake intensities were recovered and compared with the results documented in the *Task 2 Report* at three drift ratios: 1%, 2% and 3%. This was done for increasing levels of retrofit strength. The same analyses were then re-run for the four-story case, and then both the 3- and 4-story cases were re-run with the retrofit backbones used in the *Broad-Scope Analysis*.

Following is a discussion of differences in the results and the perceived causes.

F.5.1 Existing Building

Given the differences between the *Task 2* and *Broad-Scope Analyses* in viscous damping and hysteretic behavior, one might expect some difference in the results for models of the existing (unretrofitted) building. Figure F-10 shows plots of the results for the three sets of analyses. The variation among the median spectral accelerations is small at 1% or 2% drift ratios and is negligible at 3% drift. Interestingly, there is no discernable difference between the results for the 3- and 4-story buildings.

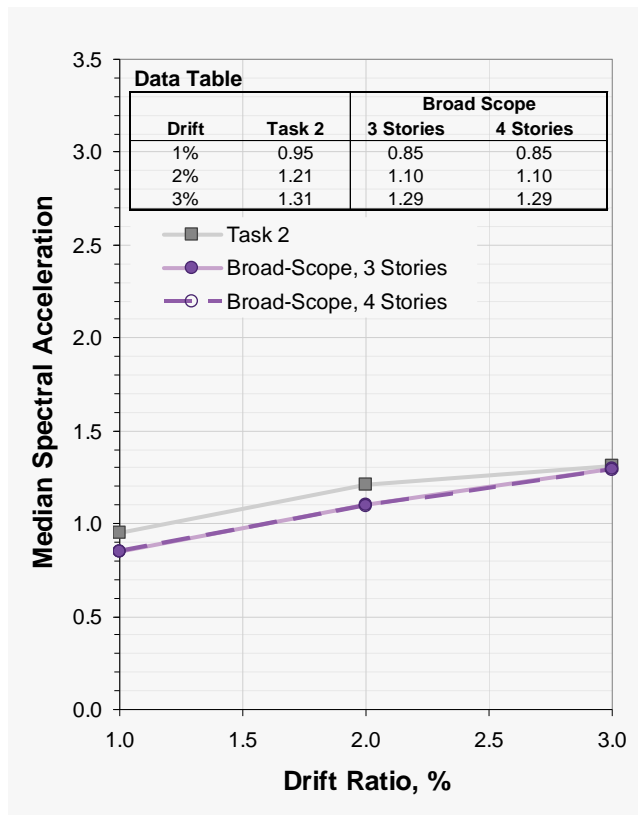

Figure F-10 Comparison of analysis results for the existing building.

F.5.2 Retrofitted Building

As discussed above, there are several significant differences in the backbone curves for the retrofitted building between the *Task 2* and *Broad-Scope Analyses*. The first difference is how the retrofit strength is defined. One would expect a difference in results if the definition of strength in one case is based on yield strength and, in the other case, is based on ultimate strength. Consider the lowest retrofit strength in Figure F-9. The *yield* strength in the *Task 2* backbone and the *ultimate* strength in the *Broad-Scope Analysis* are both equal to $0.18W$. The *Task 2* backbone yields at a larger force and smaller deflection than the corresponding *Broad-Scope* backbone, and though the backbones approach each other post-yield, they remain separated significantly.

Figure F-11 illustrates the difference in performance that arises from the two different retrofit modeling approaches and it verifies that, given equivalent assumptions, the *Task 2* and *Broad-Scope Analyses* lead to the same conclusions. The four curves plotted each represent results from the lowest level of retrofit shown in Figure F-9. The grey, upper-most curve illustrates the results from the *Task 2 Report*. The purple graph labeled *Task 2 Emulation* is the analysis done the same as in the *Broad-Scope Analyses* with

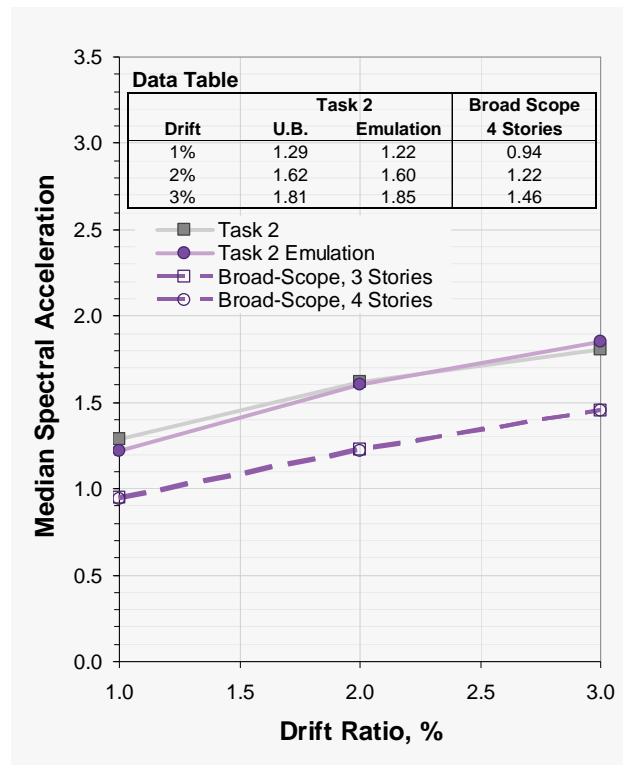

Figure F-11 Comparison of analysis results for the building with retrofit strength of V_y/V_2 of 0.2 for *Task 2* and emulation of *Task 2* and V_y/V_2 of 0.2 for the *Broad-Scope Analysis*.

three stories instead of four and with the retrofit backbone matching the *Task 2 Analysis*. The dashed, bottom-most purple graph illustrates the results using the retrofit as modeled in the *Broad-Scope Analyses*. The fact that the *Task 2* and *Task 2 Emulation* graphs are so close shows that the two analysis methods yield very similar results if the retrofit backbone curves are identical. The difference illustrated by the *Broad-Scope Analysis* model must then arise from the difference in retrofit backbone. Note again the imperceptible difference arising from modeling three versus four stories.

A comparison of the *Task 2* backbone curve for the retrofitted building, with V_y/V_2 equal to 0.2, and the *Broad-Scope Analysis* backbone curve for the retrofitted building, with V_u/V_2 equal to 0.4, is provided in Figure F-12. The performance results are illustrated in Figure F-13. Again, the only difference between the models represented by the dashed and solid lines is the difference in retrofit backbone curves illustrated in Figure F-12. The performance results show better but still not very close agreement, differing by 20% at 1% drift and 10% at 3% drift.



Figure F-12 Comparison of backbone curves for *Task 2* retrofit set with ratio $V_y/V_2 = 0.2$, and *Broad-Scope Analysis* retrofit set at $V_u/V_2 = 0.4$.

F.6 The Optimal Retrofit for Relative Strength

The *Task 2 Report* concludes that the optimal retrofit strength ratio V_y/V_2 is somewhere between 0.4 and 0.6. Beyond that strength, the drift in the upper stories controls the overall performance. To compare with the *Broad-Scope*

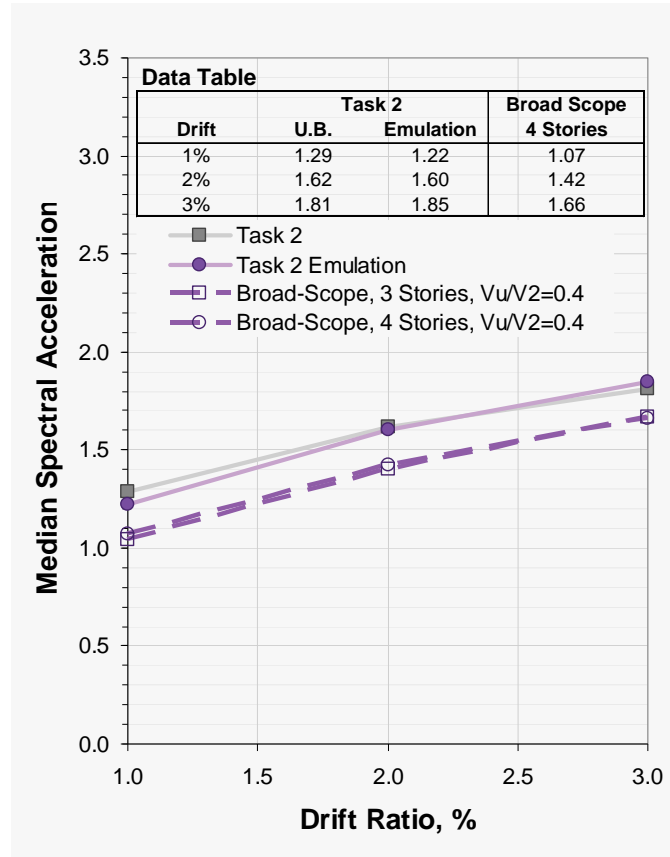

Figure F-13 Comparison of results for *Task 2* retrofit set with ratio $V_u/V_2 = 0.2$, and *Broad-Scope* retrofit set at $V_u/V_2 = 0.4$.

Analyses, consider that $V_u \approx 1.2V_y$, so the range of optimal retrofit strength ratios, V_u/V_2 , becomes 0.48 and 0.72. Because the ratio of the first and second story strength, V_1/V_2 , is equal to 0.75, this leads to a total retrofitted first-story strength, on the basis of V_u , between $1.23V_2$ and $1.47V_2$. Based on the information provided in Appendix E, the total retrofitted ground story strength (new plus existing) for optimal performance is about $1.3V_2$. Thus, the optimal retrofit strength ratio V_u/V_2 should be 0.55. This is within the range predicted by the *Task 2 Report*.

F.7 Conclusions

Though the analysis methods and assumptions used in the *Task 2 Analysis* differ in some significant ways from the *Broad-Scope Analysis*, the two approaches give results in very close agreement when the input parameters are the same. Thus, there is little difference in the results arising from differing software platforms, viscous damping and number of stories. There is also good agreement in regard to the strength of retrofit that optimizes seismic performance in the method of Relative Strength.

However, the predicted performance differs significantly depending on how the strength of the retrofit is defined and the character of the backbone curve. It was not in the scope of the *Task 2 Analysis* to study the effect of initial stiffness of the retrofit, and thus the initial stiffness was held constant for each analysis. It is noted in the *Task 2 Report* that the strength of the W14×90 frame columns can be tuned with little effect on stiffness. While this may be true, it is not likely that an owner will choose to use a large section, and cope the flanges, rather than choosing a lighter section to begin with. In that case, it is probably better to assume that the yield and ultimate drifts and the ratio of ultimate-to-yield strength are invariant for purposes of predicting performance. This is the approach used in the *Broad-Scope Analysis* that forms the basis for the recommendations in the *Guidelines*.

References

- AF&PA, 2008, *Special Design Provisions for Wind and Seismic*, ANSI/AF&PA SDPW S-2008, American Forest and Paper Association, American Wood Council, Washington, D.C.
- AISC, 2005, *Seismic Provisions for Structural Steel Buildings, Including Supplement No. 1*, ANSI/AISC 341-05, ANSI/AISC 341s1-05, American Institute of Steel Construction, Chicago.
- AISC, 2011, *Seismic Provisions for Structural Steel Buildings*, ANSI/AISC 341-10, American Institute of Steel Construction, Chicago, Illinois.
- APA, 1993, *Wood Structural Panel Shear Walls*, APA Report 154, APA – The Engineered Wood Association, Tacoma, Washington.
- APA, 2005, *Preliminary Perforated Shear Wall Testing*, APA Report T2005-83, APA – The Engineered Wood Association, Tacoma, Washington.
- Arnold, A.E., Uang, C.-M., and Filiatrault, Andre, 2003, *Cyclic Behavior and Repair of Stucco and Gypsum Woodframe Walls: Phase I*, CUREE Publication No. EDA-03, Consortium of Universities for Research in Earthquake Engineering, Richmond, California.
- ASCE, 2003, *Seismic Evaluation of Existing Buildings*, ASCE/SEI 31-03, American Society of Civil Engineers, Reston, Virginia.
- ASCE, 2006a, *Minimum Design Loads for Buildings and Other Structures*, ASCE/SEI 7-05, including *Supplement No. 1*, American Society of Civil Engineers, Reston, Virginia.
- ASCE, 2006b, *Seismic Rehabilitation of Existing Buildings*, ASCE/SEI 41-06, American Society of Civil Engineers, Reston, Virginia.
- ASCE, in preparation, *Seismic Rehabilitation of Existing Buildings*, ASCE/SEI 41-13, American Society of Civil Engineers, Reston, Virginia.
- ATC, 1984, *Tentative Provisions for the Development of Seismic Regulations for Buildings*, ATC-3-06 Amended, Second Printing; originally published in 1978, by the Applied Technology Council, Redwood City, California.

- ATC, 2009a, *Here Today – Here Tomorrow: The Road to Earthquake Resilience in San Francisco, Earthquake Safety for Soft-Story Buildings*, ATC-52-3 Report, prepared for the San Francisco Department of Building Inspection by the Applied Technology Council, Redwood City, California.
- ATC, 2009b, *Here Today – Here Tomorrow: The Road to Earthquake Resilience in San Francisco, Earthquake Safety for Soft-Story Buildings: Documentation Appendices*, ATC-52-3A Report, prepared for the San Francisco Department of Building Inspection by the Applied Technology Council, Redwood City, California.
- Bonowitz, D., and Rabinovici, S., 2011, *Soft Story Risk Reduction: Best Practice Analysis of City of Berkeley Data*, in-progress research under a Special Projects and Initiatives grant by the Earthquake Engineering Research Institute, Oakland, California.
- Chai, R., Hutchinson, T., and Vukavich, S., 2002, *Seismic Behavior of Level and Stepped Cripple Walls*, CUREE W-17 Report, Consortium of Universities for Research in Earthquake Engineering, Richmond, California.
- Christovasilis, I., Filiatrault, A., Constantinou, M., and Wanitkorkul, A., 2009, "Incremental Dynamic Analysis of Woodframe Buildings," *Earthquake Engineering & Structural Dynamics*, Vol. 38, No. 4, pp. 477-496.
- CSI, 2006, Perform-3D, Nonlinear Analysis and Performance Assessment for 3D Structures, Version 4, Computers and Structures, Inc., Berkeley, California.
- Dolan, J. D., and Johnson, A. C., 1997a, *Monotonic Tests of Long Shear Walls With Openings*, Report No. TE-1996-001, Brooks Forest Products Research Center, Virginia Polytechnic Institute and State University, Blacksburg, Virginia.
- Dolan, J. D., and Johnson, A. C., 1997b, *Cyclic Tests of Long Shear Walls With Openings*, Report No. TE-1996-002, Brooks Forest Products Research Center, Virginia Polytechnic Institute and State University, Blacksburg, Virginia.
- EERI, 1995, *Northridge Earthquake of January 17, 1994 Reconnaissance Report*, Volume 1, J. Hall, editor, Earthquake Engineering Research Institute, Oakland, California.

- EERI, 1996, *Northridge Earthquake of January 17, 1994 Reconnaissance Report*, Volume 2, W. Holmes and P. Somers, editors., Earthquake Engineering Research Institute, Oakland, California.
- Erickson, E.C.O., 1940, *New England Eastern White Pine as a House Framing Material*, U.S. Department of Agriculture, Forest Products Laboratory.
- FEMA, 2009, *Quantification of Building Seismic Performance Factors*, FEMA P695 Report, prepared by the Applied Technology Council (ATC-63 Project) for the Federal Emergency Management Agency, Washington, DC.
- Folz B, and Filiatrault A., 2004a, “A Seismic Analysis of Woodframe Structures, I.” *ASCE Journal of Structural Engineering*, Vol. 130, No. 8, pp. 1361–1370.
- Folz B, and Filiatrault A., 2004b, “A Seismic Analysis of Woodframe Structures, II: Model Implementation and Verification” *ASCE Journal of Structural Engineering*, Vol. 130, No. 8, pp. 1361–1370.
- Gatto, K., and Uang, C.-M., 2002, *Cyclic Response of Woodframe Shearwalls: Loading Protocol and Rate of Load Effects*, CUREE W-13 Report, Consortium of Universities for Research in Earthquake Engineering, Richmond, California.
- Harris, S. K., and Egan, J. A., 1992, “Effects of Ground Conditions on the Damage to Four-Story Corner Apartment Buildings,” *The Loma Prieta, California, Earthquake of October 17, 1989 – Marina District*, T. D. O’Rourke, editor, United States Government Printing Office, p. F181-F194, Washington, D.C.
- ICBO, 1964, *Uniform Building Code*, 1964 Edition, International Conference of Building Officials, Whittier, California.
- ICBO, 1973, *Uniform Building Code*, 1973 Edition, International Conference of Building Officials, Whittier, California.
- ICBO, 1988, *Uniform Building Code*, 1988 Edition, International Conference of Building Officials, Whittier, California.
- ICC, 2009a, *International Building Code*, International Code Council, Washington, D.C.
- ICC, 2009b, *International Existing Building Code*, International Code Council, Washington, D.C.

- Johnson, A. C., 1997, *Monotonic and Cyclic Performance of Long Shear Walls With Openings*, Virginia Polytechnic Institute and State University, Blacksburg, Virginia.
- Karacabeyli, E., 1997, "Lateral Resistance of Nailed Shear Walls Subjected to Static and Cyclic Displacements," *Earthquake Performance and Safety of Timber Structures*, Forest Products Society, Madison, Wisconsin.
- Kuenzi, E.W., 1951, *Results of Racking Tests of a Few Types of House-Wall Construction*, U.S. Department of Agriculture, Forest Products Laboratory, in cooperation with Housing and Home Finance Agency.
- Luco, N. et al., 2007, "Risk-Targeted Versus Current Seismic Design Maps for the Conterminous United States," *SEAOC 2007 Convention Proceedings*, Structural Engineers Association of California.
- Luxford, R. F., and Bosner, W. E., 1958, *Adequacy of Light Frame-Wall Construction*, Report No. 2137, U.S. Department of Agriculture, Forest Products Laboratory.
- Mahaney, J., and Kehoe, B., 2002, *Anchorage of Woodframe Buildings: Laboratory Test Report*, CUREE W-14 Report, Consortium of Universities for Research in Earthquake Engineering, Richmond, California.
- Maison, B., Bonowitz, D., Kornfield, L., and McCormick, D., 2011. "Adjacency Issues in Soft-Story Wood-Frame Buildings," April. Available at <http://www.seaonc.org/pdfs/AdjacencyIssuesReport.pdf>.
- McMullin, K., and Merrick, D., 2002, *Seismic Performance of Gypsum Walls: Experimental Test Program*, CUREE W-15 Report, Consortium of Universities for Research in Earthquake Engineering, Richmond, California.
- OMC, 2010, *Oakland Municipal Code, Mandatory Seismic Screening of Multiple Story Residential Buildings*, (Chapter 15.26). Published online at <http://library.municode.com/index.aspx?clientId=16308&stateId=5&stateName=California>.
- Pardoen, G., Waltman, A., Kazanjy, R., Freund, E., and Hamilton, C., 2003, *Testing and Analysis of One-Story and Two-Story Shear Walls Under Cyclic Loading*, CUREE W-25 Report, Consortium of Universities for Research in Earthquake Engineering, Richmond, California.

- Rabinovici, S. J. M., 2010, “Engineering Report Law Motivated 1 in 5 Soft-Story Apartment Owners to Retrofit: Findings from an Evaluation of Berkeley’s Approach to Soft-Story Vulnerabilities,” Poster presentation at the NEES/PEER Joint Annual Meeting, San Francisco. See also <http://gspp.berkeley.edu/news/?p=268>.
- Rabinovici, S. J. M., 2012 (forthcoming). *Motivating Private Behaviors with Public Programs: Behavioral Insights from a Local Earthquake Mitigation Ordinance*, (Doctoral Dissertation), University of California, Berkeley
- Reitherman, R., Cobeen, K., and Serban, K., 2003, *Design Documentation of Woodframe Project Index Buildings, Report No. W-29*, Consortium of Universities for Research in Earthquake Engineering, Richmond, California; 258 pages.
- Schierle, G. G., 2001, *Woodframe Project Case Studies*, CUREE W-04 Report, Consortium of Universities for Research in Earthquake Engineering, Richmond, California.
- Schmid, B., 1984, *Shear Test of Existing Wood Lath and Plaster Walls Relative to Division 88*, Ben L. Schmid Consulting Structural Engineer, Pasadena, California.
- SEAOSC, 2001, *Report of a Testing Program of Light-Framed Walls with Wood-Sheathed Shear Panels*, Structural Engineers Association of Southern California, COLA-UCI Light Frame Test Committee, Subcommittee of Research Committee and Department of Civil and Environmental Engineering, University of California, Irvine.
- SPUR, 2009, “The Resilient City, Part I: Before the Disaster,” *Urbanist*, published by San Francisco Planning & Urban Research Association, February, San Francisco, California.
- Sugiyama, H., 1981, *The Evaluation of Shear Strength of Plywood-Sheathed Walls With Openings*, Wood Industry, Vol. 36, No. 7.
- Tissell, J.R., 1993, *Wood Structural Panel Shear Walls, Appendix A*, Report 154, APA – The Engineered Wood Association, Tacoma, Washington.
- Toothman, A.J., 2003, *Monotonic and Cyclic Performance of Light-Frame Shear Walls with Various Sheathing Materials*, Virginia Polytechnic Institute and State University, Blacksburg, Virginia.

Trayer, G.W., 1956, *The Rigidity and Strength of Frame Walls, Information Reviewed and Reaffirmed Report*, No. 896, U.S. Department of Agriculture, Forest Products Laboratory.

Vamvatsikos, D., and Cornell, A. C., 2002, “The Incremental Dynamic Analysis and Its Application to Performance-Based Earthquake Engineering,” *Proceedings, 12th European Conference on Earthquake Engineering*, London, England, Paper No. 479

Project Participants

ATC Management and Oversight

Christopher Rojahn (Project Executive)
Applied Technology Council
201 Redwood Shores Parkway, Suite 240
Redwood City, California 94065

Thomas R. McLane (Project Manager)
Applied Technology Council
2111 Wilson Blvd., Suite 700
Arlington, Virginia 22201

Jon A. Heintz (Project Quality Control Monitor)
Applied Technology Council
201 Redwood Shores Parkway, Suite 240
Redwood City, California 94065

William T. Holmes (Project Technical Monitor)
Rutherford & Chekene
55 Second Street, Suite 600
San Francisco, California 94105

Federal Emergency Management Agency

Michael Mahoney (FEMA Project Officer)
Federal Emergency Management Agency
500 C Street, SW, Room 416
Washington, DC 20472

Daniel Shapiro (FEMA Technical Monitor)
SOHA Engineers
48 Colin P. Kelly Jr. Street
San Francisco, California 94107

Cathleen Carlisle (FEMA Project Monitor)
Federal Emergency Management Agency
500 C Street SW
Washington, DC 20024

Project Management Committee

David Mar (Project Technical Director)
Tipping Mar
1906 Shattuck Ave
Berkeley, California 94704

J. Dan Dolan
Washington State University
Dept. of Civil and Environmental Engineering
405 Spokane Street, Sloan 101
Pullman, Washington 99164-2910

David Bonowitz
Consulting Structural Engineer
605A Baker Street
San Francisco, California 94117

Andre Filiatrault
State University of New York
Dept. of Civil, Structural & Environ. Engineering
134 Ketter Hall
Buffalo, New York 14260-4300

Kelly Cobeen
Wiss, Janney, Elstner Associates
2200 Powell Street, Suite 925
Emeryville, California 94608

H. John Price
Curry Price Court
444 Camino Del Rio South, #201
San Diego, California 92108

Project Review Panel

Chris D. Poland (Chair)
Degenkolb Engineers
235 Montgomery Street, Suite 500
San Francisco, California 94104-2908

Tony DeMascole
Consulting Structural Engineer
3420 Market St., #6
San Francisco, California 94114

Laurence Kornfield
Manager, Earthquake Safety Implementation
Program
City and County of San Francisco
1660 Mission Street
San Francisco, California 94103-2414

Bret Lizundia
Rutherford & Chekene
55 Second Street, Suite 600
San Francisco, California 94105

Joan MacQuarrie
Chief Building Official (Retired)
City of Berkeley
2120 Milvia Street
Berkeley, California 94704

Andrew T. Merovich
A. T. Merovich & Associates, Inc.
1950 Addison Street, Suite 205
Berkeley, California 94704

Thomas Tobin
Tobin & Associates
444 Miller Avenue
Mill Valley, California 94941

Consultants

Maikol Del Carpio (Analysis Consultant)
State University of New York
Dept. of Civil, Structural & Environ. Engineering
Buffalo, New York 14260-4300

Mike Korolyk (Analysis Consultant)
Tipping Mar
1906 Shattuck Ave
Berkeley, California 94704