

Preliminary Low Impact Development Plan (LID) Butterfly Gardens

910 S. Mariposa Street
Burbank, California 91506



Prepared: December 22, 2023
Revised: May 1, 2024; October 3, 2024

Prepared for
Butterfly Gardens, LLC
625 S. Hill Street, Suite 249
Los Angeles, California 90014
(747) 271-3545

Prepared by



Consulting Engineers - Surveyors - Planners
17530 Von Karman Avenue - Suite 200
Irvine, California 92614

Telephone: 949-756-6440

**LOW IMPACT DEVELOPMENT PLAN CERTIFICATION
FOR
Butterfly Gardens**

910 S. Mariposa Street, Burbank, California 91506

I certify under penalty of law that this document and all attachments were prepared under my jurisdiction or supervision in accordance with a system designed to assure that qualified personnel properly gather and evaluate the information submitted. Based on my inquiry of the person or persons who manage the system or those persons directly responsible for the gathered information, to the best of my knowledge and belief, the information submitted is true, accurate, and complete. I am aware that there are significant penalties for submitting false information, including the possibility of fine and imprisonment for knowing violations.

By: *James H. Kawamura* Date: 10/03/2024
Name: James H. Kawamura
Title: President
Company: KHR Associates
Address: 17530 Von Karman Avenue, Suite 200, Irvine, CA 92614
Phone Number: (949) 756-6440



Table of Contents

Section 1	Project Type and Regulations	1
Section 2	Property Description	2
2.1	Existing Conditions.....	2
2.2	Proposed Conditions	2
2.3	Feasibility of Infiltration.....	2
Section 3	Hydrologic Setting	4
3.1	Watershed (Receiving Water).....	4
3.2	Existing Drainage Patterns.....	5
3.3	Proposed Drainage Patterns	5
Section 4	Best Management Practices (BMPs).....	7
4.1	Project Site Anticipated and Potential Pollutants	7
4.2	Site Design BMPs.....	8
4.3	Source Control BMPs	11
4.4	Treatment Control BMPs.....	13
Section 5	Inspection/Maintenance of BMPs	15
5.1	Inspection and Maintenance Responsibility	15
5.2	Inspection and Maintenance Arrangements.....	15
5.3	Reporting Standards.....	15
5.4	Post-Construction Best Management Practices	16
Appendix 1	Area/Vicinity Map	20
Appendix 2	Design Plans & LID Exhibit.....	23
Appendix 3	Educational Material	24
Appendix 4	LID BMPs	25
Appendix 4.1	MaxWell IV Drywell Information.....	26
Appendix 4.2	Aqua-Swirl Information.....	27
Appendix 4.3	Corrugated Metal Pipe (CMP) Information	28
Appendix 5	Calculations	29
Appendix 6	Operations & Maintenance Documents	33
Appendix 7	Geotechnical Investigation.....	34

Section 1 Project Type and Regulations

Zone: M-1 Limited Industrial (Rancho Master Plan Overlay)

Project Area: 0.88 acres (38,361 square feet) after dedication (43,689 square feet prior)

Priority Project Category: Designated Project (Redevelopment Project where 50 percent or more of the impervious surface of a previously developed site is proposed to be altered and the previous development project was not subject to post-construction stormwater quality control measures, and which are developments that result in creation or addition of 5,000 square feet or more of impervious surface on a site that was previously developed as described in Section 2-1 of County of Los Angeles Department of Public Works of Low Impact Development Standards Manual dated February 2014.)

Assessor's Number: 2443-004-017

Legal Description:

THE LAND REFERRED TO HEREIN BELOW IS SITUATED IN THE CITY OF BURBANK, COUNTY OF LOS ANGELES, STATE OF CALIFORNIA AND IS DESCRIBED AS FOLLOWS:

THAT PORTION OF BLOCK SIXTY-NINE (69) OF THE SUBDIVISION OF RANCHO PROVIDENCIA AND SCOTT TRACT, IN THE CITY OF BURBANK, COUNTY OF LOS ANGELES, STATE OF CALIFORNIA, AS PER MAP RECORDED IN BOOK 43, PAGE 47 AT ET SEQ. OF MISCELLANEOUS RECORDS, IN THE OFFICE OF THE RECORDER OF SAID COUNTY, DESCRIBED AS FOLLOWS:

BEGINNING AT A POINT IN THE WEST LINE OF SAID BLOCK DISTANT NORTH 23° WEST THREE HUNDRED FIFTY-FIVE AND EIGHTEEN HUNDREDTHS (355.18) FEET FROM THE MOST SOUTHERLY CORNER OF SAID BLOCK AS SAID CORNER IS SHOWN ON A MAP OF TRACT NO. 9766, AS PER MAP RECORDED IN BOOK 137, PAGE 84, ET SEQ., OF MAPS; THENCE ALONG THE WEST LINE OF SAID BLOCK NORTH 23° WEST ONE HUNDRED FORTY-FOUR (144) FEET; THENCE NORTH 74° 10' 45" EAST FIVE HUNDRED SEVENTY-SIX AND FIFTY-THREE HUNDREDTHS (576.53) FEET FROM THE MOST SOUTHERLY CORNER OF SAID BLOCK; THENCE ALONG SAID EAST LINE SOUTH 14° 58' 10" WEST ONE HUNDRED SIXTY-SIX AND TEN HUNDREDTHS (166.10) FEET; THENCE SOUTH 74° 08' 17" WEST TWO HUNDRED FIFTY-FOUR AND FORTY-NINE HUNDREDTHS (254.49) FEET TO THE POINT OF BEGINNING.

Rain Season: October 1st through April 15th

Watershed: Los Angeles River Watershed

Regulations: National Pollution Discharge Elimination System (NPDES) Municipal Separate Storm Sewer System (MS4) Permit (CAS004001, Order No. R4-2012-0175); Los Angeles County Code Title 12, Chapter 84

Regulatory Agents: City of Burbank Director of Public Works, their authorized deputy, agent, representative or inspector (including other county departments); U.S. Environmental Protection Agency; State Water Resources Control Board; Los Angeles County Flood Control District; and Los Angeles Regional Water Quality Control Board

Section 2 Property Description

2.1 Existing Conditions

The proposed project is located at 910 S. Mariposa Street, in the City of Burbank, California. The project site is bounded by a commercial site to the north, a powerline easement then Los Angeles Equestrian Center to the east, a horse corral structure, horse trail, and then Los Angeles River to the south, and Mariposa Street and single family residential to the west. **Appendix 1** illustrates the project vicinity and provides an aerial perspective of the project site and immediate surroundings

The project site is currently developed with covered stables, horse corrals, several single story structures, and natural ground. The project site's existing conditions prior to dedication include approximately 16,355 square feet (0.37 acres) of impervious surfaces (37%) and 27,334 square feet (0.63 acres) of pervious surfaces (63%) on a 43,689 square feet (1.00 acres) site. The project site's existing conditions excluding the dedication area include approximately 15,679 square feet (0.36 acres) of impervious surfaces (41%) and 22,682 square feet (0.52 acres) of pervious surfaces (63%) on a 38,361 square feet (0.88 acres) site.

2.2 Proposed Conditions

The proposed *Butterfly Gardens* residential development project entails the construction of a 5-story multi-family residential building with 40 condominium units and a 47 space partially subterranean parking garage on a 0.88-acre (38,361 square feet) site. Stormwater mitigation calculations for the proposed site conditions assumed 37,861 square feet (0.87 acres) of impervious area (99%) and 500 square feet (0.01 acres) of landscaping as a worst case scenario. The project will also include miscellaneous improvements including sidewalks, curb, gutter, utilities, and storm drains.

2.3 Feasibility of Infiltration

According to the information taken from the Geotechnical Investigation by Geocon West, Inc., dated January 10, 2023 (see **Appendix 7**), the site contains artificial fill to depths of 9 feet below existing ground surface consisting of sandy silt and silty sand. The alluvium below the fill generally consists of brown to grayish brown, gray, or olive brown interbedded silt and sand with varying amounts of silt and fine to coarse gravel. Borings B1 and B2 encountered very dense poorly graded to well-graded sand at depths below approximately 25 to 26 feet to the bottom of borings. The alluvial soils are characterized as slightly moist to moist and very loose to very dense or very soft to hard. Groundwater was not encountered in any of the borings to the maximum explored depth of 55.5 feet below existing grade. The City of Burbank Safety Element (2013) indicates that groundwater levels are expected to remain deeper than 50 feet.

For infiltration feasibility, the project's subsurface materials shall have a design infiltration rate equal to or greater than 0.3 inches per hour. Geocon's infiltration test performed near the center portion of the site resulted in a measured infiltration rate of 10.62 inches per hour at a depth between 20-30 feet. To determine the design infiltration rate, the soils engineer recommends a test reduction factor (RF_t) of 1.0 and a site variability reduction factor (RF_v) of 1.0 to be applied to the

measured percolation rate with the engineer to determine the appropriate long-term siltation, plugging and maintenance reduction factor (RF_s). KHR (the design engineer) determined a RF_s of 1.0 is appropriate due to site conditions and pretreatment method. The total RF is 3.0 (Total Reduction Factor, $RF = RF_t + RF_v + RF_s$) making a design infiltration rate of 3.54 inches per hour. Due to the feasibility of infiltration on the southerly portion of the site, harvest and use was not considered for the project.

Stormwater infiltration has been determined to be feasible for the project. Stormwater infiltration practices operate by capturing and temporarily storing stormwater, before allowing it to infiltrate into the underlying soil. A solid walled Corrugated Metal Pipe (CMP) is used to store the stormwater mitigation volume captured within the project site for infiltration by a drywell into the underlying soils. The stormwater will be collected throughout the site by a proposed private storm drainage system. The project's stormwater quality design flow (SWQDF) is diverted to an Aqua-Swirl Hydrodynamic Separator unit that will be used for pretreatment prior to infiltration. The infiltration system will drawdown in approximately 30.79 hours, which is under the maximum drawdown rate of 96 hours. A total of 8,900 cubic feet of stormwater can be drawdown by the drywell in a 96 hour period.

Section 3 Hydrologic Setting

3.1 Watershed (Receiving Water)

The project site is located within the 834 square mile Los Angeles River Watershed. The receiving waters directly affected by the proposed development include Los Angeles River (Reaches 4 through 1), Los Angeles River Estuary, and San Pedro Bay. The Final 2020-2022 California Integrated Report (Clean Water Act Section 303(d) list/305(b) Report) has the downstream receiving waters impaired for:

Los Angeles River Reach 4 303d/TMDLs

- Indicator Bacteria
- Nutrients (Algae)
- Toxicity
- Trash

Los Angeles River Reach 3 303d/TMDL

- Ammonia
- Copper
- Indicator Bacteria
- Nutrients (Algae)
- Toxicity
- Trash

Los Angeles River Reach 2 303d/TMDL

- Ammonia
- Copper
- Indicator Bacteria
- Lead
- Nutrients (Algae)
- Oil
- Trash

Los Angeles River Reach 1 303d/TMDL

- Ammonia
- Cadmium
- Copper, Dissolved
- Cyanide
- Indicator Bacteria
- Lead
- Nutrients (Algae)

- pH
- Trash
- Zinc, Dissolved

Los Angeles River Estuary (Queensway Bay)
303d/TMDL

- Chlordane
- DDT (sediment)
- PCBs (Polychlorinated biphenyls) (sediment)
- Toxicity
- Trash

San Pedro Bay/Offshore Zone
303d/TMDL

- Chlordane
- PCBs (Polychlorinated biphenyls)
- Total DDT (sum of 4,4'- and 2,4'- isomers of DDT, DDE, and DDD)
- Toxicity

3.2 Existing Drainage Patterns

Runoff from a majority of the site sheet flows easterly into the adjacent property, and runoff from the remainder of the site sheet flows westerly to Mariposa Street, which flows to a LACFCD maintained catch basin on the westerly side of the street. The catch basin connects to a LACFCD maintained 36-inch reinforced concrete pipe (RCP) that discharges into the Los Angeles River.

3.3 Proposed Drainage Patterns

The proposed project site is comprised of a single Drainage Management Area (DMA). The DMA totals approximately 38,361 square feet (0.88 acres). Stormwater from the DMA will be collected by a private drainage system that diverts the stormwater quality design flow (SWQDF) to an Aqua-Swirl for pretreatment prior to detention by a corrugated metal pipe (CMP) and infiltration into the underlying soils by means of a MaxWell IV drywell. Flows in excess of the stormwater volume to be mitigated will bypass the treatment system and be pumped out through a parkway culvert into Mariposa Street.

Following is a table that summarize the results of the calculations for sizing of the proposed infiltration system, along with the Aqua-Swirl unit used for pretreatment. The volume storage for the infiltration system consists of the 6 foot by 95 foot CMP along with the MaxWell IV drywell chamber and aggregate (see **Appendix 4.1** and **4.3** for manufacture's literature). The treated flow rate for the Aqua-Swirl system is taken from the manufacturer's literature (see **Appendix 4.2**). Calculations are provided in **Appendix 5**.

LID BMP Summary							
DMA	Mitigation Volume/ Flow	Aqua-Swirl Model/ Flow Rate	CMP Size/ Volume	MaxWell IV Volume	System Volume	Design Infiltration Rate	Drawdown Time
1	2,826 cf/ 0.299 cfs	AS-2/ 1.1 cfs	6'x95' 2,691 cf	163 cf	2,854 cf	3.54 in/hr	30.79 hrs

Section 4 Best Management Practices (BMPs)

Best Management Practices (BMPs) describe how the project complies with each post construction water quality management practices. Locations of BMPs are shown on plot plan in Appendix 2.

Pollutant of Concern Summary Table for Multi-Family

Pollutants of Concern	
Suspended Solids	X
Total Phosphorus	
Total Nitrogen	
Total Kjeldahl Nitrogen	
Cadmium, Total	*
Chromium, Total	*
Copper, Total	X
Lead, Total	
Zinc, Total	X

*No available data to determine if these pollutants of concern originate from this land use. Pollutant is assumed to be produced by this land use unless otherwise proven by the project applicant.

4.1 Project Site Anticipated and Potential Pollutants

Stormwater/urban runoff pollutants associated with the project are as follows: Pollutants such as heavy metals, organic compounds, oil and grease, as well as trash and debris, are anticipated due to vehicles and people. On-site landscaped areas have the potential for nutrients, pesticides, sediments, and oxygen demanding substances and pavement has the potential of bacteria to pollute the sites runoff.

4.1.1 Description of Water Pollutants

Bacteria and Viruses – Bacteria and Viruses are ubiquitous microorganisms that thrive under certain environmental conditions. Their proliferation is typically caused by the transport of animal or human fecal wastes from the watershed. Water, containing excessive bacteria and viruses, can alter the aquatic habitat and create a harmful environment for humans and aquatic life. In addition, the decomposition of excess organic waste causes increased growth of undesirable organisms in the water.

Nutrients – Nutrients are inorganic substances, such as nitrogen and phosphorus. Excessive discharge of nutrients to water bodies and streams causes eutrophication, where aquatic plants and algae growth can lead to excessive decay of organic matter in the water body, loss of oxygen in the water, release of toxins in sediment, and the eventual death of aquatic organisms. Primary sources of nutrients in urban runoff are fertilizers and eroded soils.

Metals – Metals are raw material components in non-metal products such as fuels, paints, and other coatings. Primary source of metal pollution in stormwater are typically commercially available metals and metal products. Metals of concern include cadmium, chromium, copper, lead, mercury, and zinc. Lead and chromium have been used as corrosion inhibitors in primer coatings and cooling tower systems. At low concentrations naturally occurring in soil, metals are non-toxic. However, at higher concentrations, certain metals can be toxic to aquatic life. Humans can be impacted from contaminated groundwater resources, and bioaccumulation of metals in fish and shellfish. Environmental concerns, regarding the potential for release of metals to the environment, have already led to restricted metal usage in certain applications.

Pesticides – Pesticides (including herbicides) are chemical compounds commonly used to control nuisance growth or prevalence of organisms. Relatively low levels of the active component of pesticides can result in conditions of aquatic toxicity. Excessive or improper application of a pesticide may result in runoff containing toxic levels of its active ingredient.

Organic Compounds – Organic compounds are carbon-based. Commercially available or naturally occurring organic compounds are found in pesticides, solvents, and hydrocarbons. Organic compounds can, at certain concentrations, indirectly or directly constitute a hazard to life or health. When rinsing off objects, toxic levels of solvents and cleaning compounds can be discharged to storm drains. Dirt, grease, and grime retained in the cleaning fluid or rinse water may also adsorb levels of organic compounds that are harmful or hazardous to aquatic life.

Sediments – Sediments are soils or other surficial materials eroded and then transported or deposited by the action of wind, water, ice, or gravity. Sediments can increase turbidity, clog fish gills, reduce spawning habitat, lower young aquatic organisms survival rates, smother bottom dwelling organisms, and suppress aquatic vegetation growth.

Trash and Debris – Trash (such as paper, plastic, polystyrene packing foam, and aluminum materials) and biodegradable organic matter (such as leaves, grass cuttings, and food waste) are general waste products on the landscape. The presence of trash and debris may have a significant impact on the recreational value of a water body and aquatic habitat. Trash impacts water quality by increasing biochemical oxygen demand.

Oxygen-Demanding Substances – This category includes biodegradable organic material as well as chemicals that react with dissolved oxygen in water to form other compounds. Proteins, carbohydrates, and fats are examples of biodegradable organic compounds. Compounds such as ammonia and hydrogen sulfide are examples of oxygen-demanding compounds. The oxygen demand of a substance can lead to depletion of dissolved oxygen in a water body and possibly the development of septic conditions.

4.2 *Site Design BMPs*

Low-Impact Development (LID) practices control rainfall and stormwater runoff at or close to the source protecting surface and groundwater quality, maintaining the integrity of ecosystems, and preserving the physical integrity of receiving waters. The techniques focus on mimicking pre-

development hydrology by retaining, detaining, and/or evaporating runoff on-site minimizing the ability for downstream impacts.

LID goals are to increase groundwater recharge, enhance water quality, and prevent degradation to downstream natural drainage courses. This means that development projects shall treat stormwater pollutants, reduce stormwater runoff volume, and promote groundwater infiltration and stormwater reuse in turn protecting water quality and managing water resources.

Conserving Natural Areas

The entire project site will be developed for the proposed project.

Minimize Disturbances to Natural Drainage Patterns

The entire project site will be developed for the proposed project. The proposed storm drain system will discharge into the MS4 that accepted the existing discharge.

Minimizing and Disconnecting Impervious Surfaces

Drive aisles and sidewalks are designed to the minimum widths allowed.

Minimizing Soil Compaction

Soil compaction rates will be determined based upon jurisdictional codes and regulations.

Directing Runoff from Impervious Areas to Infiltration Areas

Impervious areas will be collected by area drains/drop inlets and directed to drywell for infiltration.

Trash Storage Areas

Trash receptacles are located/stored within the parking garage.

Integrated Pest Management (IPM) Principles

Pesticides are to be used only after monitoring indicates they are needed according to established guidelines. Pest control materials are selected and applied in manners that minimize risks to human health, non-targeted organisms and the environment. IPM educational materials will be distributed to landscapers. Minimally, educational materials must address the following topics:

- Keeping pests out of buildings and landscaping using barriers, screens and caulking
- Physical pest elimination techniques, such as, weeding, squashing, trapping, washing or pruning out pests;
- Relying on natural enemies to eat pest
- Proper use of pesticides as a last line of defense.

Efficient Irrigation Systems and Landscape Design

Rain shut-off devices will be incorporated into the landscape design and attached to all the irrigation control systems. Each landscape area will be irrigated according to the specific watering needs of the individual vegetation grouped. Flow reducers, shut off valves or similar water pressure

based systems will be used and checked yearly to insure they are in proper working order. Broken heads or lines will be replaced within a timely manner.

Stormwater Conveyance System Stenciling and Signage

Stenciling & Signage are required for all new catch basins and inlets proposed. The property owner and its responsible party shall perform yearly inspection and re-stenciling if needed. Stenciling detail is shown in the BMP exhibit in the appendix of this report.

4.3 Source Control BMPs

Routine Structural BMPs

Name	Included	Not Applicable	Reason for N/A
SD-13 Provide storm drain system stenciling and signage.	X		
Design and construct outdoor material storage areas to reduce pollution introduction.		X	The proposed project site does not contain any outdoor storage areas.
SD-32 Design and construct trash and waste storage areas to reduce pollution introduction.		X	Trash receptacles are located/stored within the private residence of each home.
SD-12 Use efficient irrigation systems & landscape design, water conservation, smart controllers, and source control.	X		
Protect slopes and channels and provide energy dissipation		X	Not necessary for proposed project.
Dock Areas		X	The proposed project does not contain any dock areas.
Maintenance Bays		X	The proposed project does not contain any maintenance bays areas.
Vehicle wash areas		X	The proposed project site does not contain any vehicle wash areas.
Outdoor processing areas		X	The proposed project site does not contain any outdoor processing areas.
Equipment wash areas		X	The proposed project does not contain any equipment wash areas.
Fueling areas		X	The proposed project site does not contain any fueling areas.
Hillside landscaping		X	The proposed project site does not contain any hillside landscaping.
Wash water control for food preparation areas.		X	The proposed project site does not contain any food preparation areas.
Community car wash racks.		X	The proposed project site does not contain any community car wash racks or areas.

Routine Structural BMPs – Detailed Reference Guide

SD-13 Storm Drain Signage/Stenciling

The on-site proposed paved surface drop inlets, curb inlet, and landscape area drain inlets will use City markers that state “No Dumping – Drains to Ocean.” Inspections of drop inlet markers shall be done on a bi-annual basis. Re-stenciling shall be done as needed, or at minimum every five years, to ensure legibility. See CASQA BMP SD-13 in **Appendix 3**.

SD-12 Use Efficient Irrigation Systems and Landscaping Design

Landscaping will consist of drought tolerant or native plants, grouped by similar irrigation needs. Any plant materials shall be installed and maintained in a neat, vigorous, and healthy condition. Irrigation will be monitored to establish proper time of watering. Rain shutoff devices and shut off valves/flow reducers will be used to prevent erosion, over watering, and prolong plant life. The irrigation system shall minimize excess irrigation and irrigation runoff throughout the project site.

Landscaping and irrigation systems will be inspected monthly and maintained as needed. See CASQA BMP SD-12 in **Appendix 3**.

Routine Non-Structural BMPs – Detailed Reference Guide

Education

Educational materials for good housekeeping practices, this report, as well as other applicable stormwater BMP materials will be distributed by the owner and/or Homeowners Associate (HOA) to all employees and contractors that will perform any task affiliated with the BMPs mentioned within this report. Materials will be presented upon hire and materials review will be done annually. Refer to section **5.4 Post-Construction Best Management Practices** for inspection and maintenance routine.

Activity Restrictions

No outdoor storage shall be permitted.

No hosing down of any paved surfaces will occur where the result would be the flow of non-stormwater into the street or storm drains.

No dumping of any waste into drop inlets or catch basins.

No blowing or sweeping of debris such as leaf litter, grass clippings, miscellaneous litter, etc. into catch basins, curb inlets, or streets.

These and any other restrictions shall be adhered to daily.

Refer to section **5.4 Post-Construction Best Management Practices** for inspection and maintenance routine.

Common Landscape Management

Maintenance shall include trimming, mowing, weeding, removal of litter, fertilizing, water conservation, and replacement of dead, diseased, or dying plants. Any plant materials shall be installed and maintained in a neat, vigorous, and healthy condition. Irrigation will be monitored to establish proper time of watering. Landscape waste will be properly disposed of. Any fertilizer or pesticides used will be done so sparingly, according to Federal, State, and County standards, and applied in accordance with the directions on the label. Landscape Management shall be performed on a monthly basis. Irrigation Management shall be done in accordance with the landscapes watering schedule. Refer to section **5.4 Post-Construction Best Management Practices** for inspection and maintenance routine. See CASQA BMP SC-41 in **Appendix 3**.

BMP Maintenance

BMP maintenance refers to the proper inspection and maintenance of all Routine Structural BMPs, Non-Structural BMPs, and Treatment Control BMPs mentioned within this report at the frequencies specified. Record of inspections and maintenances shall be made and kept on-site. BMP Maintenance shall be adhered to on a daily basis. See **Appendix 2** for locations of BMPs. Refer to section **5.4 Post-Construction Best Management Practices** for inspection and maintenance routine.

Common Area Litter Control

Routine maintenance shall consist of litter control throughout entire site, closing trash can lids, cleaning area around trash can, emptying trash containers throughout the site and inspecting and implementing the Best Management Practices. Common Area Litter Control shall be adhered to on a weekly basis. Refer to section **5.4 Post-Construction Best Management Practices** for inspection and maintenance routine. See CASQA BMP SC-34 in **Appendix 3**.

Common Area Catch Basin Inspection

Inspection and maintenance of the on-site catch basins shall be performed monthly during the non-rainy season and after each storm event during the rainy season to prevent any potential debris or pollutants from entering into the storm drain system. Refer to section **5.4 Post-Construction Best Management Practices** for inspection and maintenance routine. See CASQA BMP SC-44 in **Appendix 3**.

Street Sweeping Private Streets and Parking Lots

Surface inspection of the parking lot area shall be performed at least on a monthly basis. The parking lot areas shall be swept and cleaned monthly to prevent potential debris and pollutants from entering into storm drain system. Washing of streets and parking lots is prohibited. Refer to section **5.4 Post-Construction Best Management Practices** for inspection and maintenance routine. See CASQA BMP SC-43 in **Appendix 3**.

4.4 Treatment Control BMPs

Treatment control BMPs are the last ditch effort to remove any pollutants introduced into the runoff prior to being discharged from the site. Preventing or stopping pollution at the source is more effective than trying to clean up and repair a polluted water body. Refer to **Appendix 5** for BMP Calculations.

MaxWell IV (Drywell used for Infiltration)

The project site will use a MaxWell IV drywell to direct captured stormwater into the subsoil, thereby reducing stormwater volume and pollutants through infiltration. The drywell shall be inspected quarterly for accumulated sediment as well as trash and debris. The routine visual inspection will help insure the system is cleaned out at appropriate times. Schedules for inspections and cleanout will be based on storm events and pollutant accumulation. Accumulation of sediment and floatable material captured within the drywell will be recorded in a maintenance log. System should be cleaned when inspection reveals that sediment or trash is accumulating over the bottom of the system, and at a minimum, within 5 days of October 1st of each year. A truck mounted hydro-vactor equipment is typically used to remove the accumulated sediment and debris. The geotextile fabric base seals and hydrophobic petrochemical sponges will be removed and replaced when performing maintenance. Should it be necessary to get inside the system to perform maintenance activities, all appropriate precautions regarding confined space entry and OSHA regulations should be followed. Refer to **Appendix 4.1** for more product information and **Appendix 2** for location.

Aqua-Swirl (Pre-treatment)

The AquaShield Aqua-Swirl is a hydrodynamic separation device used for pre-treatment of runoff. The Aqua-Swirl shall be inspected quarterly to ensure that the unit is functioning properly (no blockages or obstructions to inlet and/or separation screen), measuring the amount of solid materials that have accumulated in the sump, the amount of fine sediment accumulated behind the screen, and determining the amount of floating trash and debris in the separation chamber. This can be done with a calibrated “dip stick” so that the depth of the deposition can be tracked. Schedules for inspections and cleanout will be based on storm events and pollutant accumulation. Accumulation of sediment and floatable material will be recorded in a maintenance log. Maintenance is required when the top of the sediment pile is measured to be 30 to 32 inches below standing water surface, and at a minimum, within 5 days of October 1st of each year. Free-floating oil and floatable debris can be observed and removed directly through the service access riser provided. A vacuum truck is typically used to remove the accumulated sediment and debris. Refer to **Appendix 4.2** for more product information and **Appendix 2** for location.

Corrugated Metal Pipe (CMP used for detention of mitigation volume)

The project site will use a CMP (corrugated metal pipe) designed to detain and direct captured stormwater to a drywell for infiltration into the subsurface soils. The CMP shall be inspected quarterly for accumulated sediment as well as trash and debris. The routine visual inspection will help insure the system is cleaned out at appropriate times. Schedules for inspections and cleanout will be based on storm events and pollutant accumulation. Accumulation of sediment and floatable material captured within CMP will be recorded in a maintenance log. System should be cleaned when inspection reveals that sediment or trash is accumulating over the bottom of the system, and at a minimum, within 5 days of October 1st of each year. A vacuum truck is typically used to remove the accumulated sediment and debris. Should it be necessary to get inside the system to perform maintenance activities, all appropriate precautions regarding confined space entry and OSHA regulations should be followed. Refer to **Appendix 4.3** for more product information and **Appendix 2** for location.

Section 5 Inspection/Maintenance of BMPs

5.1 Inspection and Maintenance Responsibility

On-going inspection and maintenance of all structural, non-structural, and treatment control BMPs for this site, as well as funding for the inspection and maintenance program, is the responsibility of Butterfly Gardens, LLC, represented by Garen Gozumian, at 625 Hill Street, Suite 249, Los Angeles, CA 90014, (747) 271-3545, until a Homeowners Association (HOA) is established for the site. In the developed condition, the HOA shall be responsible for the long-term funding, maintenance and inspection of the project's stormwater facilities. Areas within private residential lots will be the responsibility of the homeowner.

A qualified and trained representative who can perform and maintain the Best Management Practices for the site shall perform inspections and maintenance. Any transfer of ownership does not nullify the responsibility of BMP inspections and maintenance. The new owners shall maintain the Best Management Practices and their requirements as described in this report. In case of emergency, the BMPs representative contact information, with name, number, address and area of responsibility will be kept on site. Training documentation is to be provided by the HOA and their representative.

5.2 Inspection and Maintenance Arrangements

Inspection and Maintenance Arrangements are the responsibility of the owner. Throughout the course of the year, inspection and maintenance of the BMPs shall occur at the times designated within this report. During site inspection, any damaged BMPs shall be replaced and/or repaired as soon as possible to maintain the BMPs effectiveness. The rainy season for this area is from October 1st through April 15th.

5.3 Reporting Standards

Attachments, inspection logs and Checklist of Activities are to be used for documentation and proof of maintaining the Best Management Practices. As needed, forms can be revised to meet the requirements for the County or State agencies. Additionally, Spills and the Material Inventory list along with a sampling Event Reporting Form should be used. If requested by the County these reporting standards shall be enforced and filed to the State.

All inspections and maintenance required by this report and any LID violations found shall be reported and documented for the purposes of maintaining the Best Management Practices and their requirements. The inspection and maintenance log shall be kept on-site. The log is critical for proving water quality compliance. The log shall be made available on-site and shall be reviewed and inspected upon request by governing agencies. Any reports and logs shall be maintained for three years and shall include the inspector, date, observation location of best management practices and locations of inadequate and improper BMPs, along with any additional BMPs that are used and needed. The report shall require the signature of the qualified inspector.

5.4 *Post-Construction Best Management Practices*

Listed on the next page are areas that the Best Management Practices are required to be implemented. Locations of BMPs are on plot plan in **Appendix 2**. Operations and Maintenance Plan for LID BMPs can be found in **Appendix 6** of this report.

BMP Name and BMP Implementation, Maintenance, and Inspection Procedures	Implementation, Maintenance, and Inspection Frequency and Schedule	Person or Entity with Operation & Maintenance Responsibility
Non-Structural Source Control BMPs		
<p>Education for Property Owners, Tenants and Occupants Educational materials for good housekeeping practices, this report, as well as other applicable stormwater BMP materials will be distributed by the owner to all employees and contractors that will perform any task affiliated with the BMPs mentioned within this report. Materials will be presented upon hire and materials review will be done annually.</p>	<p>Provide O&M Plan and educational materials to Owner upon completion. Materials will be presented upon hire and a materials review will be done annually for all employees/contractors that will perform any tasks affiliated with BMPs mentioned within the LID.</p>	<p>Owner</p>
<p>Activity Restriction No outdoor storage shall be permitted. No hosing down of any paved surfaces will occur where the result would be the flow of non-stormwater into the street or storm drains. No dumping of any waste into drop inlets or catch basins. No blowing or sweeping of debris such as leaf litter, grass clippings, miscellaneous litter, etc. into catch basins, area drains, or streets. These and any other restrictions shall be adhered to daily.</p>	<p>Daily basis</p>	<p>Owner</p>
<p>Common Area Landscape Management Maintenance shall include trimming, mowing, weeding, removal of litter, fertilizing, water conservation, and replacement of dead, diseased, or dying plants. Any plant materials shall be installed and maintained in a neat, vigorous, and healthy condition. Irrigation will be monitored to establish proper time of watering and determine if there are any leaks or damage to the system. Any performance problems or damage to the irrigation system shall be repaired immediately. Landscape waste will be properly disposed of. Any fertilizer or pesticides used will be done so sparingly, according to Federal, State, and County standards, and applied in accordance with the directions on the label. Landscape management and inspection of the irrigation system shall occur on a weekly basis. CASQA BMP SC-41</p>	<p>As required, or monthly at a minimum</p>	<p>Owner</p>

BMP Name and BMP Implementation, Maintenance, and Inspection Procedures	Implementation, Maintenance, and Inspection Frequency and Schedule	Person or Entity with Operation & Maintenance Responsibility
<p>BMP Maintenance BMP maintenance refers to the proper inspection and maintenance at specified frequencies of all Routine Structural BMPs, Non-Structural BMPs, and Treatment Control BMPs mentioned within the project's LID report. Record of inspections and maintenances shall be made and kept on-site. BMP Maintenance shall be adhered to as required.</p>	Daily basis	Owner
<p>Common Area Litter Control Routine maintenance shall consist of litter control throughout entire site, closing trash can lids, cleaning area around trash can, emptying trash containers throughout the site and inspecting and implementing the Best Management Practices. Common Area Litter Control shall be adhered to on a weekly basis. CASQA BMP SC-34</p>	Weekly sweeping and trash pick-up. Daily inspection of trash receptacles.	Owner
<p>Employee Training Training will begin with a general review and explanation of stormwater/urban runoff and its effect on the environment. Applicable Federal, State, and City stormwater requirements will be discussed including stormwater discharge prohibitions, and wastewater discharge requirements. New employees/contractors are to be given a basic orientation on all aspects of pollution preventative measures, and shall begin training immediately after hire (i.e. within 30 days of the start date) and shall be required to attend meetings thereafter, as scheduled by the property owner. An annual BMP meeting, at a minimum, will be conducted on preventative measures, inspection, and maintenance. This LID report shall be reviewed at the meetings. Documentation of training as well as the individuals responsible for preparation, implementation, and compliance shall be kept on-site.</p>	Materials will be presented upon hire and a materials review will be done annually for all employees/contractors that will perform any tasks affiliated with BMPs mentioned within the LID.	Owner
<p>Common Area Catch Basin Inspection Storm drainage systems shall be inspected, and if necessary, cleaned (when sump is 40% full), repaired, or replaced prior to the start of each rainy season (October 1st). Area drains shall be cleaned of any obstruction and foreign material every three months, within 5 days prior to October 1st, and after every rain event. Repair any damage to catch basins or drop inlets. Drainage facilities include catch basins (area drains) and retention (infiltration) systems. CASQA BMP SC-44</p>	Once every three months, once within 5 days of October 1st, and after every rainstorm event.	Owner

BMP Name and BMP Implementation, Maintenance, and Inspection Procedures	Implementation, Maintenance, and Inspection Frequency and Schedule	Person or Entity with Operation & Maintenance Responsibility
<p>Street Sweeping Private Streets and Parking Lots Surface inspection of the parking lot area shall be performed at least on a monthly basis. The parking lot areas shall be swept and cleaned monthly to prevent potential debris and pollutants from entering into storm drain system. Washing of streets and parking lots is prohibited. CASQA BMP SC-43</p>	Monthly basis.	Owner
Structural Source Control BMPs		
<p>Provide Storm Drain System Stenciling and Signage The on-site proposed drop inlets will use markers that state "No Dumping – Drains to Ocean." Inspection of drop inlet markers shall be done bi-annually for legibility. Re-stenciling shall be done as needed, with a minimum frequency of every five years, to ensure legibility. CASQA BMP SD-13</p>	Inspect bi-annually. Re-stenciling is required, at a minimum, every five years.	Owner
<p>Use Efficient Irrigation Systems & Landscape Design Landscaping will consist of drought tolerant or native plants, grouped by similar irrigation needs. Any plant materials shall be installed and maintained in a neat, vigorous, and healthy condition. Irrigation will be monitored to establish proper time of watering. Rain shutoff devices and shut off valves/flow reducers will be used to prevent erosion, over watering, and prolong plant life. The irrigation system shall minimize excess irrigation and irrigation runoff throughout the project site. Landscaping and irrigation systems will be inspected weekly and maintained as needed. CASQA BMP SD-12</p>	Inspect monthly and maintain as needed.	Owner

Appendix 1 Area/Vicinity Map

Vicinity Map

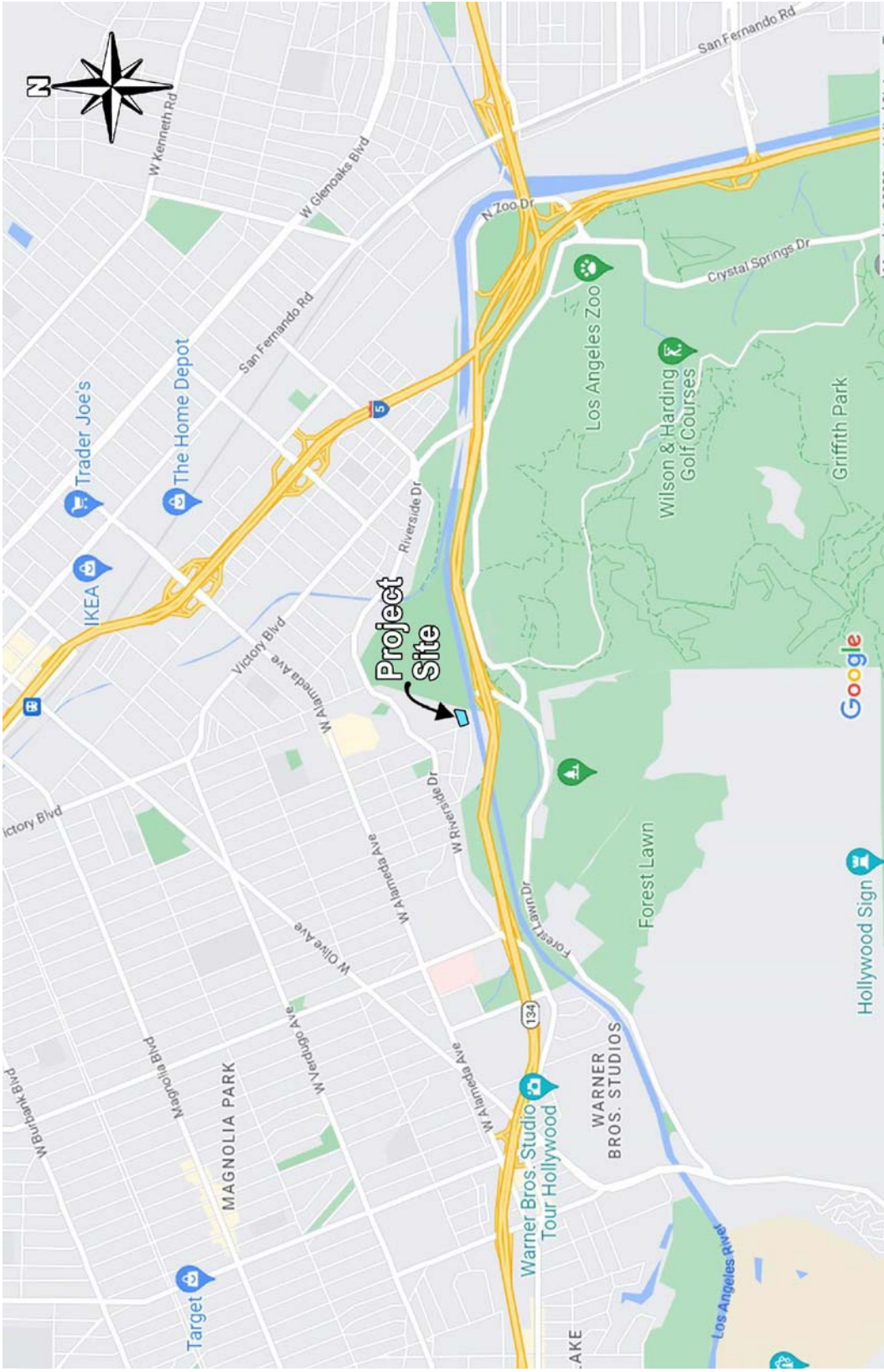

Aerial Map



Appendix 2 Design Plans & LID Exhibit



1-STORY COMMERCIAL BUILDING
820 S. MARIPOSA ST.

1-STORY HOUSE
914 S. MARIPOSA ST.

MARIPOSA STREET

VALLEY HEART DRIVE

PROJECT SUMMARY

EXISTING SITE CONDITIONS (INCLUDING DEDICATION AREA)
 SITE AREA: 43,689 S.F. (1.00 ACRES)
 IMPERVIOUS AREA: 16,355 S.F. (0.37 ACRES)
 PERVIOUS AREA: 27,334 S.F. (0.63 ACRES)
 IMPERVIOUS %: 37%

EXISTING SITE CONDITIONS (EXCLUDING DEDICATION AREA)
 SITE AREA: 38,361 S.F. (0.88 ACRES)
 IMPERVIOUS AREA: 15,679 S.F. (0.36 ACRES)
 PERVIOUS AREA: 22,682 S.F. (0.52 ACRES)
 IMPERVIOUS %: 41%

PROPOSED SITE CONDITIONS (EXCLUDES DEDICATION AREA)
 SITE AREA: 38,361 S.F. (0.88 ACRES)
 IMPERVIOUS AREA: 37,861 S.F. (0.87 ACRES)
 PERVIOUS AREA: 500 S.F. (0.01 ACRES)
 IMPERVIOUS %: 99%

85TH PERCENTILE DEPTH: 1 IN.
 DESIGN CONTROL VOLUME (DCV): 2,826 C.F.
 STORMWATER QUALITY DESIGN FLOW (SQDF): 0.299 C.F.S.

LEGEND

- DESCRIPTION**
- SP-12 & SC-41: PERMEABLE AREA (LANDSCAPE AREA)
 - SC-41: IMPERMEABLE ROOF SURFACES
 - SD-32 & SC-34: TRASH ENCLOSURE
 - SC-41: IMPERMEABLE HARDSCAPE AREA
 - WATER FEATURE
 - SC-43: IMPERMEABLE VEHICULAR SURFACE
 - SC-44: PROPOSED PRIVATE STORM DRAIN
 - UNDERGROUND DETENTION TANK (CMP)
 - PROPOSED MAXWELL IV DRYWELL
 - PROPOSED AQUA-SWIRL
 - ONSITE SURFACE FLOW DIRECTION
 - OFFSITE SURFACE FLOW DIRECTION
 - LID BMP DRAINAGE AREA BOUNDARY
 - DMA #
 - DMA AREA
- SYMBOL**
- [Green Box]
 - [Orange Box]
 - [Blue Box]
 - [Red Box]
 - [Blue Arrow]
 - [Black Arrow]
 - [Red Dashed Line]
 - [Red Circle with X]

LID BMP SUMMARY

AREA ID	MITIGATION VOLUME	CMP SIZE	CMP VOLUME	MAXWELL IV VOLUME	SYSTEM VOLUME	INFILTRATION RATE	DRAWDOWN TIME	96 HOUR VOLUME
1	2,826 CF	6' x 95'	2,691 CF	163 CF	2,854 CF	3.54 IN/HR	30.79 HRS	8,900 CF

AQUA-SWIRL (PRE-TREATMENT)

AREA ID	MITIGATION FLOW	AQUA-SWIRL AS-2 TREATED FLOW RATE
1	0.299 CFS	1.1 CFS

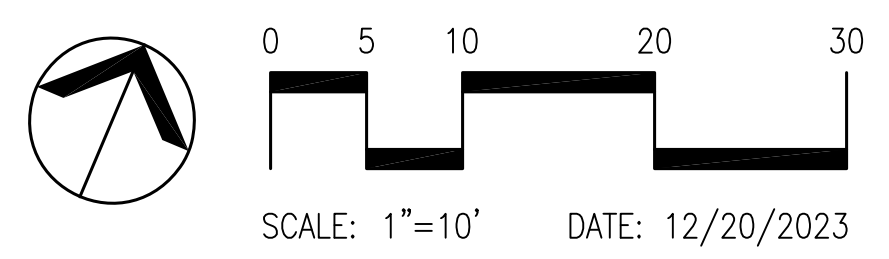

BUTTERFLY GARDENS
BUTTERFLY GARDENS LLC

PRELIMINARY LID BMP EXHIBIT
 910 S. MARIPOSA STREET, BURBANK, CALIFORNIA 91506

KHR ASSOCIATES
 CONSULTING ENGINEERS/SURVEYORS/PLANNERS
 17530 Von Karman Avenue - Suite 200
 Irvine, California 92614

C:\Users\khr\OneDrive\Documents\Burbank\820 S. MARIPOSA ST. PRELIMINARY LID BMP EXHIBIT.dwg, 12/20/2023, 1:02:28 PM

Appendix 3 Educational Material



Design Objectives

- ✓ Maximize Infiltration
- ✓ Provide Retention
- ✓ Slow Runoff
- Minimize Impervious Land Coverage
- Prohibit Dumping of Improper Materials
- Contain Pollutants
- Collect and Convey

Description

Irrigation water provided to landscaped areas may result in excess irrigation water being conveyed into stormwater drainage systems.

Approach

Project plan designs for development and redevelopment should include application methods of irrigation water that minimize runoff of excess irrigation water into the stormwater conveyance system.

Suitable Applications

Appropriate applications include residential, commercial and industrial areas planned for development or redevelopment. (Detached residential single-family homes are typically excluded from this requirement.)

Design Considerations

Designing New Installations

The following methods to reduce excessive irrigation runoff should be considered, and incorporated and implemented where determined applicable and feasible by the Permittee:

- Employ rain-triggered shutoff devices to prevent irrigation after precipitation.
- Design irrigation systems to each landscape area's specific water requirements.
- Include design featuring flow reducers or shutoff valves triggered by a pressure drop to control water loss in the event of broken sprinkler heads or lines.
- Implement landscape plans consistent with County or City water conservation resolutions, which may include provision of water sensors, programmable irrigation times (for short cycles), etc.



- Design timing and application methods of irrigation water to minimize the runoff of excess irrigation water into the storm water drainage system.
- Group plants with similar water requirements in order to reduce excess irrigation runoff and promote surface filtration. Choose plants with low irrigation requirements (for example, native or drought tolerant species). Consider design features such as:
 - Using mulches (such as wood chips or bar) in planter areas without ground cover to minimize sediment in runoff
 - Installing appropriate plant materials for the location, in accordance with amount of sunlight and climate, and use native plant materials where possible and/or as recommended by the landscape architect
 - Leaving a vegetative barrier along the property boundary and interior watercourses, to act as a pollutant filter, where appropriate and feasible
 - Choosing plants that minimize or eliminate the use of fertilizer or pesticides to sustain growth
- Employ other comparable, equally effective methods to reduce irrigation water runoff.

Redeveloping Existing Installations

Various jurisdictional stormwater management and mitigation plans (SUSMP, WQMP, etc.) define “redevelopment” in terms of amounts of additional impervious area, increases in gross floor area and/or exterior construction, and land disturbing activities with structural or impervious surfaces. The definition of “redevelopment” must be consulted to determine whether or not the requirements for new development apply to areas intended for redevelopment. If the definition applies, the steps outlined under “designing new installations” above should be followed.

Other Resources

A Manual for the Standard Urban Stormwater Mitigation Plan (SUSMP), Los Angeles County Department of Public Works, May 2002.

Model Standard Urban Storm Water Mitigation Plan (SUSMP) for San Diego County, Port of San Diego, and Cities in San Diego County, February 14, 2002.

Model Water Quality Management Plan (WQMP) for County of Orange, Orange County Flood Control District, and the Incorporated Cities of Orange County, Draft February 2003.

Ventura Countywide Technical Guidance Manual for Stormwater Quality Control Measures, July 2002.



Design Objectives

- Maximize Infiltration
- Provide Retention
- Slow Runoff
- Minimize Impervious Land Coverage
- ✓ Prohibit Dumping of Improper Materials
- Contain Pollutants
- Collect and Convey

Description

Waste materials dumped into storm drain inlets can have severe impacts on receiving and ground waters. Posting notices regarding discharge prohibitions at storm drain inlets can prevent waste dumping. Storm drain signs and stencils are highly visible source controls that are typically placed directly adjacent to storm drain inlets.

Approach

The stencil or affixed sign contains a brief statement that prohibits dumping of improper materials into the urban runoff conveyance system. Storm drain messages have become a popular method of alerting the public about the effects of and the prohibitions against waste disposal.

Suitable Applications

Stencils and signs alert the public to the destination of pollutants discharged to the storm drain. Signs are appropriate in residential, commercial, and industrial areas, as well as any other area where contributions or dumping to storm drains is likely.

Design Considerations

Storm drain message markers or placards are recommended at all storm drain inlets within the boundary of a development project. The marker should be placed in clear sight facing toward anyone approaching the inlet from either side. All storm drain inlet locations should be identified on the development site map.

Designing New Installations

The following methods should be considered for inclusion in the project design and show on project plans:

- Provide stenciling or labeling of all storm drain inlets and catch basins, constructed or modified, within the project area with prohibitive language. Examples include “NO DUMPING –



DRAINS TO OCEAN” and/or other graphical icons to discourage illegal dumping.

- Post signs with prohibitive language and/or graphical icons, which prohibit illegal dumping at public access points along channels and creeks within the project area.

Note - Some local agencies have approved specific signage and/or storm drain message placards for use. Consult local agency stormwater staff to determine specific requirements for placard types and methods of application.

Redeveloping Existing Installations

Various jurisdictional stormwater management and mitigation plans (SUSMP, WQMP, etc.) define “redevelopment” in terms of amounts of additional impervious area, increases in gross floor area and/or exterior construction, and land disturbing activities with structural or impervious surfaces. If the project meets the definition of “redevelopment”, then the requirements stated under “designing new installations” above should be included in all project design plans.

Additional Information

Maintenance Considerations

- Legibility of markers and signs should be maintained. If required by the agency with jurisdiction over the project, the owner/operator or homeowner’s association should enter into a maintenance agreement with the agency or record a deed restriction upon the property title to maintain the legibility of placards or signs.

Placement

- Signage on top of curbs tends to weather and fade.
- Signage on face of curbs tends to be worn by contact with vehicle tires and sweeper brooms.

Supplemental Information

Examples

- Most MS4 programs have storm drain signage programs. Some MS4 programs will provide stencils, or arrange for volunteers to stencil storm drains as part of their outreach program.

Other Resources

A Manual for the Standard Urban Stormwater Mitigation Plan (SUSMP), Los Angeles County Department of Public Works, May 2002.

Model Standard Urban Storm Water Mitigation Plan (SUSMP) for San Diego County, Port of San Diego, and Cities in San Diego County, February 14, 2002.

Model Water Quality Management Plan (WQMP) for County of Orange, Orange County Flood Control District, and the Incorporated Cities of Orange County, Draft February 2003.

Ventura Countywide Technical Guidance Manual for Stormwater Quality Control Measures, July 2002.

Description

Trash storage areas are areas where a trash receptacle (s) are located for use as a repository for solid wastes. Stormwater runoff from areas where trash is stored or disposed of can be polluted. In addition, loose trash and debris can be easily transported by water or wind into nearby storm drain inlets, channels, and/or creeks. Waste handling operations that may be sources of stormwater pollution include dumpsters, litter control, and waste piles.

Approach

This fact sheet contains details on the specific measures required to prevent or reduce pollutants in stormwater runoff associated with trash storage and handling. Preventative measures including enclosures, containment structures, and impervious pavements to mitigate spills, should be used to reduce the likelihood of contamination.

Suitable Applications

Appropriate applications include residential, commercial and industrial areas planned for development or redevelopment. (Detached residential single-family homes are typically excluded from this requirement.)

Design Considerations

Design requirements for waste handling areas are governed by Building and Fire Codes, and by current local agency ordinances and zoning requirements. The design criteria described in this fact sheet are meant to enhance and be consistent with these code and ordinance requirements. Hazardous waste should be handled in accordance with legal requirements established in Title 22, California Code of Regulation.

Wastes from commercial and industrial sites are typically hauled by either public or commercial carriers that may have design or access requirements for waste storage areas. The design criteria in this fact sheet are recommendations and are not intended to be in conflict with requirements established by the waste hauler. The waste hauler should be contacted prior to the design of your site trash collection areas. Conflicts or issues should be discussed with the local agency.

Designing New Installations

Trash storage areas should be designed to consider the following structural or treatment control BMPs:

- ④ Design trash container areas so that drainage from adjoining roofs and pavement is diverted around the area(s) to avoid run-on. This might include berming or grading the waste handling area to prevent run-on of stormwater.
- ④ Make sure trash container areas are screened or walled to prevent off-site transport of trash.

Design Objectives

- Maximize Infiltration
- Provide Retention
- Slow Runoff
- Minimize Impervious Land Coverage
- Prohibit Dumping of Improper Materials
- ☐ Contain Pollutants
- Collect and Convey



- ④ Use lined bins or dumpsters to reduce leaking of liquid waste.
- ④ Provide roofs, awnings, or attached lids on all trash containers to minimize direct precipitation and prevent rainfall from entering containers.
- ④ Pave trash storage areas with an impervious surface to mitigate spills.
- ④ Do not locate storm drains in immediate vicinity of the trash storage area.
- ④ Post signs on all dumpsters informing users that hazardous materials are not to be disposed of therein.

Redeveloping Existing Installations

Various jurisdictional stormwater management and mitigation plans (SUSMP, WQMP, etc.) define “redevelopment” in terms of amounts of additional impervious area, increases in gross floor area and/or exterior construction, and land disturbing activities with structural or impervious surfaces. The definition of “redevelopment” must be consulted to determine whether or not the requirements for new development apply to areas intended for redevelopment. If the definition applies, the steps outlined under “designing new installations” above should be followed.

Additional Information

Maintenance Considerations

The integrity of structural elements that are subject to damage (i.e., screens, covers, and signs) must be maintained by the owner/operator. Maintenance agreements between the local agency and the owner/operator may be required. Some agencies will require maintenance deed restrictions to be recorded of the property title. If required by the local agency, maintenance agreements or deed restrictions must be executed by the owner/operator before improvement plans are approved.

Other Resources

A Manual for the Standard Urban Stormwater Mitigation Plan (SUSMP), Los Angeles County Department of Public Works, May 2002.

Model Standard Urban Storm Water Mitigation Plan (SUSMP) for San Diego County, Port of San Diego, and Cities in San Diego County, February 14, 2002.

Model Water Quality Management Plan (WQMP) for County of Orange, Orange County Flood Control District, and the Incorporated Cities of Orange County, Draft February 2003.

Ventura Countywide Technical Guidance Manual for Stormwater Quality Control Measures, July 2002.



Objectives

- ④ Cover
- ④ Contain
- ④ Educate
- ④ Reduce/Minimize
- ④ Product Substitution

Description

Improper storage and handling of solid wastes can allow toxic compounds, oils and greases, heavy metals, nutrients, suspended solids, and other pollutants to enter stormwater runoff. The discharge of pollutants to stormwater from waste handling and disposal can be prevented and reduced by tracking waste generation, storage, and disposal; reducing waste generation and disposal through source reduction, reuse, and recycling; and preventing run-on and runoff.

Targeted Constituents

Sediment	
Nutrients	
Trash	
Metals	✓
Bacteria	✓
Oil and Grease	✓
Organics	✓

Approach

Pollution Prevention

- ④ Accomplish reduction in the amount of waste generated using the following source controls:
 - Production planning and sequencing
 - Process or equipment modification
 - Raw material substitution or elimination
 - Loss prevention and housekeeping
 - Waste segregation and separation
 - Close loop recycling
- ④ Establish a material tracking system to increase awareness about material usage. This may reduce spills and minimize contamination, thus reducing the amount of waste produced.
- ④ Recycle materials whenever possible.



Suggested Protocols***General***

- ④ Cover storage containers with leak proof lids or some other means. If waste is not in containers, cover all waste piles (plastic tarps are acceptable coverage) and prevent stormwater run-on and runoff with a berm. The waste containers or piles must be covered except when in use.
- ④ Use drip pans or absorbent materials whenever grease containers are emptied by vacuum trucks or other means. Grease cannot be left on the ground. Collected grease must be properly disposed of as garbage.
- ④ Check storage containers weekly for leaks and to ensure that lids are on tightly. Replace any that are leaking, corroded, or otherwise deteriorating.
- ④ Sweep and clean the storage area regularly. If it is paved, do not hose down the area to a storm drain.
- ④ Dispose of rinse and wash water from cleaning waste containers into a sanitary sewer if allowed by the local sewer authority. Do not discharge wash water to the street or storm drain.
- ④ Transfer waste from damaged containers into safe containers.
- ④ Take special care when loading or unloading wastes to minimize losses. Loading systems can be used to minimize spills and fugitive emission losses such as dust or mist. Vacuum transfer systems can minimize waste loss.

Controlling Litter

- ④ Post “No Littering” signs and enforce anti-litter laws.
- ④ Provide a sufficient number of litter receptacles for the facility.
- ④ Clean out and cover litter receptacles frequently to prevent spillage.

Waste Collection

- ④ Keep waste collection areas clean.
- ④ Inspect solid waste containers for structural damage regularly. Repair or replace damaged containers as necessary.
- ④ Secure solid waste containers; containers must be closed tightly when not in use.
- ④ Do not fill waste containers with washout water or any other liquid.
- ④ Ensure that only appropriate solid wastes are added to the solid waste container. Certain wastes such as hazardous wastes, appliances, fluorescent lamps, pesticides, etc., may not be disposed of in solid waste containers (see chemical/ hazardous waste collection section below).

- ④ Do not mix wastes; this can cause chemical reactions, make recycling impossible, and complicate disposal.

Good Housekeeping

- ④ Use all of the product before disposing of the container.
- ④ Keep the waste management area clean at all times by sweeping and cleaning up spills immediately.
- ④ Use dry methods when possible (e.g., sweeping, use of absorbents) when cleaning around restaurant/food handling dumpster areas. If water must be used after sweeping/using absorbents, collect water and discharge through grease interceptor to the sewer.

Chemical/Hazardous Wastes

- ④ Select designated hazardous waste collection areas on-site.
- ④ Store hazardous materials and wastes in covered containers and protect them from vandalism.
- ④ Place hazardous waste containers in secondary containment.
- ④ Make sure that hazardous waste is collected, removed, and disposed of only at authorized disposal areas.
- ④ Stencil or demarcate storm drains on the facility's property with prohibitive message regarding waste disposal.

Run-on/Runoff Prevention

- ④ Prevent stormwater run-on from entering the waste management area by enclosing the area or building a berm around the area.
- ④ Prevent waste materials from directly contacting rain.
- ④ Cover waste piles with temporary covering material such as reinforced tarpaulin, polyethylene, polyurethane, polypropylene or hypalon.
- ④ Cover the area with a permanent roof if feasible.
- ④ Cover dumpsters to prevent rain from washing waste out of holes or cracks in the bottom of the dumpster.
- ④ Move the activity indoor after ensuring all safety concerns such as fire hazard and ventilation are addressed.

Inspection

- ④ Inspect and replace faulty pumps or hoses regularly to minimize the potential of releases and spills.
- ④ Check waste management areas for leaking containers or spills.

- ④ Repair leaking equipment including valves, lines, seals, or pumps promptly.

Training

- ④ Train staff in pollution prevention measures and proper disposal methods.
- ④ Train employees and contractors in proper spill containment and cleanup. The employee should have the tools and knowledge to immediately begin cleaning up a spill should one occur.
- ④ Train employees and subcontractors in proper hazardous waste management.

Spill Response and Prevention

- ④ Keep your Spill Prevention Control and Countermeasure (SPCC) Plan up-to-date.
- ④ Have an emergency plan, equipment and trained personnel ready at all times to deal immediately with major spills
- ④ Collect all spilled liquids and properly dispose of them.
- ④ Store and maintain appropriate spill cleanup materials in a location known to all near the designated wash area.
- ④ Ensure that vehicles transporting waste have spill prevention equipment that can prevent spills during transport. Spill prevention equipment includes:
 - Vehicles equipped with baffles for liquid waste
 - Trucks with sealed gates and spill guards for solid waste

Other Considerations (Limitations and Regulations)

Hazardous waste cannot be reused or recycled; it must be disposed of by a licensed hazardous waste hauler.

Requirements

Costs

Capital and O&M costs for these programs will vary substantially depending on the size of the facility and the types of waste handled. Costs should be low if there is an inventory program in place.

Maintenance

- ④ None except for maintaining equipment for material tracking program.

Supplemental Information

Further Detail of the BMP

Land Treatment System

Minimize runoff of polluted stormwater from land application by:

- ④ Choosing a site where slopes are under 6%, the soil is permeable, there is a low water table, it is located away from wetlands or marshes, and there is a closed drainage system

- ④ Avoiding application of waste to the site when it is raining or when the ground is saturated with water
- ④ Growing vegetation on land disposal areas to stabilize soils and reduce the volume of surface water runoff from the site
- ④ Maintaining adequate barriers between the land application site and the receiving waters (planted strips are particularly good)
- ④ Using erosion control techniques such as mulching and matting, filter fences, straw bales, diversion terracing, and sediment basins
- ④ Performing routine maintenance to ensure the erosion control or site stabilization measures are working

Examples

The port of Long Beach has a state-of-the-art database for identifying potential pollutant sources, documenting facility management practices, and tracking pollutants.

References and Resources

California's Nonpoint Source Program Plan <http://www.swrcb.ca.gov/nps/index.html>

Clark County Storm Water Pollution Control Manual
<http://www.co.clark.wa.us/pubworks/bmpman.pdf>

Solid Waste Container Best Management Practices – Fact Sheet On-Line Resources – Environmental Health and Safety. Harvard University. 2002.

King County Storm Water Pollution Control Manual <http://dnr.metrokc.gov/wlr/dss/spcm.htm>

Pollution from Surface Cleaning Folder. 1996. Bay Area Stormwater Management Agencies Association (BASMAA). <http://www.basmaa.org>

Santa Clara Valley Urban Runoff Pollution Prevention Program <http://www.scvurppp.org>

The Storm Water Managers Resource Center <http://www.stormwatercenter.net/>



Description

Stormwater runoff from building and grounds maintenance activities can be contaminated with toxic hydrocarbons in solvents, fertilizers and pesticides, suspended solids, heavy metals, abnormal pH, and oils and greases. Utilizing the protocols in this fact sheet will prevent or reduce the discharge of pollutants to stormwater from building and grounds maintenance activities by washing and cleaning up with as little water as possible, following good landscape management practices, preventing and cleaning up spills immediately, keeping debris from entering the storm drains, and maintaining the stormwater collection system.

Approach

Reduce potential for pollutant discharge through source control pollution prevention and BMP implementation. Successful implementation depends on effective training of employees on applicable BMPs and general pollution prevention strategies and objectives.

Pollution Prevention

- Switch to non-toxic chemicals for maintenance when possible.
- Choose cleaning agents that can be recycled.
- Encourage proper lawn management and landscaping, including use of native vegetation.

Objectives

- Cover
- Contain
- Educate
- Reduce/Minimize
- Product Substitution

Targeted Constituents

Sediment	✓
Nutrients	✓
Trash	
Metals	✓
Bacteria	✓
Oil and Grease	
Organics	



SC-41 Building & Grounds Maintenance

- Encourage use of Integrated Pest Management techniques for pest control.
- Encourage proper onsite recycling of yard trimmings.
- Recycle residual paints, solvents, lumber, and other material as much as possible.

Suggested Protocols

Pressure Washing of Buildings, Rooftops, and Other Large Objects

- In situations where soaps or detergents are used and the surrounding area is paved, pressure washers must use a water collection device that enables collection of wash water and associated solids. A sump pump, wet vacuum or similarly effective device must be used to collect the runoff and loose materials. The collected runoff and solids must be disposed of properly.
- If soaps or detergents are not used, and the surrounding area is paved, wash runoff does not have to be collected but must be screened. Pressure washers must use filter fabric or some other type of screen on the ground and/or in the catch basin to trap the particles in wash water runoff.
- If you are pressure washing on a grassed area (with or without soap), runoff must be dispersed as sheet flow as much as possible, rather than as a concentrated stream. The wash runoff must remain on the grass and not drain to pavement.

Landscaping Activities

- Dispose of grass clippings, leaves, sticks, or other collected vegetation as garbage, or by composting. Do not dispose of collected vegetation into waterways or storm drainage systems.
- Use mulch or other erosion control measures on exposed soils.

Building Repair, Remodeling, and Construction

- Do not dump any toxic substance or liquid waste on the pavement, the ground, or toward a storm drain.
- Use ground or drop cloths underneath outdoor painting, scraping, and sandblasting work, and properly dispose of collected material daily.
- Use a ground cloth or oversized tub for activities such as paint mixing and tool cleaning.
- Clean paintbrushes and tools covered with water-based paints in sinks connected to sanitary sewers or in portable containers that can be dumped into a sanitary sewer drain. Brushes and tools covered with non-water-based paints, finishes, or other materials must be cleaned in a manner that enables collection of used solvents (e.g., paint thinner, turpentine, etc.) for recycling or proper disposal.
- Use a storm drain cover, filter fabric, or similarly effective runoff control mechanism if dust, grit, wash water, or other pollutants may escape the work area and enter a catch basin. This is particularly necessary on rainy days. The containment device(s) must be in place at the beginning of the work day, and accumulated dirty runoff and solids must be collected and disposed of before removing the containment device(s) at the end of the work day.

- If you need to de-water an excavation site, you may need to filter the water before discharging to a catch basin or off-site. If directed off-site, you should direct the water through hay bales and filter fabric or use other sediment filters or traps.
- Store toxic material under cover during precipitation events and when not in use. A cover would include tarps or other temporary cover material.

Mowing, Trimming, and Planting

- Dispose of leaves, sticks, or other collected vegetation as garbage, by composting or at a permitted landfill. Do not dispose of collected vegetation into waterways or storm drainage systems.
- Use mulch or other erosion control measures when soils are exposed.
- Place temporarily stockpiled material away from watercourses and drain inlets, and berm or cover stockpiles to prevent material releases to the storm drain system.
- Consider an alternative approach when bailing out muddy water: do not put it in the storm drain; pour over landscaped areas.
- Use hand weeding where practical.

Fertilizer and Pesticide Management

- Follow all federal, state, and local laws and regulations governing the use, storage, and disposal of fertilizers and pesticides and training of applicators and pest control advisors.
- Use less toxic pesticides that will do the job when applicable. Avoid use of copper-based pesticides if possible.
- Do not use pesticides if rain is expected.
- Do not mix or prepare pesticides for application near storm drains.
- Use the minimum amount needed for the job.
- Calibrate fertilizer distributors to avoid excessive application.
- Employ techniques to minimize off-target application (e.g., spray drift) of pesticides, including consideration of alternative application techniques.
- Apply pesticides only when wind speeds are low.
- Fertilizers should be worked into the soil rather than dumped or broadcast onto the surface.
- Irrigate slowly to prevent runoff and then only as much as is needed.
- Clean pavement and sidewalk if fertilizer is spilled on these surfaces before applying irrigation water.
- Dispose of empty pesticide containers according to the instructions on the container label.

SC-41 Building & Grounds Maintenance

- Use up the pesticides. Rinse containers, and use rinse water as product. Dispose of unused pesticide as hazardous waste.
- Implement storage requirements for pesticide products with guidance from the local fire department and County Agricultural Commissioner. Provide secondary containment for pesticides.

Inspection

- Inspect irrigation system periodically to ensure that the right amount of water is being applied and that excessive runoff is not occurring. Minimize excess watering and repair leaks in the irrigation system as soon as they are observed.

Training

- Educate and train employees on pesticide use and in pesticide application techniques to prevent pollution.
- Train employees and contractors in proper techniques for spill containment and cleanup.
- Be sure the frequency of training takes into account the complexity of the operations and the nature of the staff.

Spill Response and Prevention

- Keep your Spill Prevention Control and Countermeasure (SPCC) Plan up-to-date.
- Place a stockpile of spill cleanup materials, such as brooms, dustpans, and vacuum sweepers (if desired) near the storage area where it will be readily accessible.
- Have employees trained in spill containment and cleanup present during the loading/unloading of dangerous wastes, liquid chemicals, or other materials.
- Familiarize employees with the Spill Prevention Control and Countermeasure Plan.
- Clean up spills immediately.

Other Considerations

Alternative pest/weed controls may not be available, suitable, or effective in many cases.

Requirements

Costs

- Cost will vary depending on the type and size of facility.
- Overall costs should be low in comparison to other BMPs.

Maintenance

Sweep paved areas regularly to collect loose particles. Wipe up spills with rags and other absorbent material immediately, do not hose down the area to a storm drain.

Supplemental Information

Further Detail of the BMP

Fire Sprinkler Line Flushing

Building fire sprinkler line flushing may be a source of non-stormwater runoff pollution. The water entering the system is usually potable water, though in some areas it may be non-potable reclaimed wastewater. There are subsequent factors that may drastically reduce the quality of the water in such systems. Black iron pipe is usually used since it is cheaper than potable piping, but it is subject to rusting and results in lower quality water. Initially, the black iron pipe has an oil coating to protect it from rusting between manufacture and installation; this will contaminate the water from the first flush but not from subsequent flushes. Nitrates, poly-phosphates and other corrosion inhibitors, as well as fire suppressants and antifreeze may be added to the sprinkler water system. Water generally remains in the sprinkler system a long time (typically a year) and between flushes may accumulate iron, manganese, lead, copper, nickel, and zinc. The water generally becomes anoxic and contains living and dead bacteria and breakdown products from chlorination. This may result in a significant BOD problem and the water often smells. Consequently dispose fire sprinkler line flush water into the sanitary sewer. Do not allow discharge to storm drain or infiltration due to potential high levels of pollutants in fire sprinkler line water.

References and Resources

California's Nonpoint Source Program Plan <http://www.swrcb.ca.gov/nps/index.html>

Clark County Storm Water Pollution Control Manual
<http://www.co.clark.wa.us/pubworks/bmpman.pdf>

King County Storm Water Pollution Control Manual <http://dnr.metrokc.gov/wlr/dss/spcm.htm>

Mobile Cleaners Pilot Program: Final Report. 1997. Bay Area Stormwater Management Agencies Association (BASMAA). <http://www.basmaa.org/>

Pollution from Surface Cleaning Folder. 1996. Bay Area Stormwater Management Agencies Association (BASMAA). <http://www.basmaa.org/>

Santa Clara Valley Urban Runoff Pollution Prevention Program <http://www.scvurppp.org>

The Storm Water Managers Resource Center <http://www.stormwatercenter.net/>

Parking/Storage Area Maintenance SC-43



Description

Parking lots and storage areas can contribute a number of substances, such as trash, suspended solids, hydrocarbons, oil and grease, and heavy metals that can enter receiving waters through stormwater runoff or non-stormwater discharges. The protocols in this fact sheet are intended to prevent or reduce the discharge of pollutants from parking/storage areas and include using good housekeeping practices, following appropriate cleaning BMPs, and training employees.

Approach

The goal of this program is to ensure stormwater pollution prevention practices are considered when conducting activities on or around parking areas and storage areas to reduce potential for pollutant discharge to receiving waters. Successful implementation depends on effective training of employees on applicable BMPs and general pollution prevention strategies and objectives.

Pollution Prevention

- Encourage alternative designs and maintenance strategies for impervious parking lots. (See New Development and Redevelopment BMP Handbook)
- Keep accurate maintenance logs to evaluate BMP implementation.

Objectives

- Cover
- Contain
- Educate
- Reduce/Minimize
- Product Substitution

Targeted Constituents

Sediment	✓
Nutrients	
Trash	✓
Metals	✓
Bacteria	
Oil and Grease	✓
Organics	✓



SC-43 Parking/Storage Area Maintenance

Suggested Protocols

General

- Keep the parking and storage areas clean and orderly. Remove debris in a timely fashion.
- Allow sheet runoff to flow into biofilters (vegetated strip and swale) and/or infiltration devices.
- Utilize sand filters or oleophilic collectors for oily waste in low quantities.
- Arrange rooftop drains to prevent drainage directly onto paved surfaces.
- Design lot to include semi-permeable hardscape.
- Discharge soapy water remaining in mop or wash buckets to the sanitary sewer through a sink, toilet, clean-out, or wash area with drain.

Controlling Litter

- Post “No Littering” signs and enforce anti-litter laws.
- Provide an adequate number of litter receptacles.
- Clean out and cover litter receptacles frequently to prevent spillage.
- Provide trash receptacles in parking lots to discourage litter.
- Routinely sweep, shovel, and dispose of litter in the trash.

Surface Cleaning

- Use dry cleaning methods (e.g., sweeping, vacuuming) to prevent the discharge of pollutants into the stormwater conveyance system if possible.
- Establish frequency of public parking lot sweeping based on usage and field observations of waste accumulation.
- Sweep all parking lots at least once before the onset of the wet season.
- Follow the procedures below if water is used to clean surfaces:
 - Block the storm drain or contain runoff.
 - Collect and pump wash water to the sanitary sewer or discharge to a pervious surface. Do not allow wash water to enter storm drains.
 - Dispose of parking lot sweeping debris and dirt at a landfill.
- Follow the procedures below when cleaning heavy oily deposits:
 - Clean oily spots with absorbent materials.
 - Use a screen or filter fabric over inlet, then wash surfaces.

Parking/Storage Area Maintenance SC-43

- Do not allow discharges to the storm drain.
- Vacuum/pump discharges to a tank or discharge to sanitary sewer.
- Appropriately dispose of spilled materials and absorbents.

Surface Repair

- Preheat, transfer or load hot bituminous material away from storm drain inlets.
- Apply concrete, asphalt, and seal coat during dry weather to prevent contamination from contacting stormwater runoff.
- Cover and seal nearby storm drain inlets where applicable (with waterproof material or mesh) and manholes before applying seal coat, slurry seal, etc. Leave covers in place until job is complete and all water from emulsified oil sealants has drained or evaporated. Clean any debris from these covered manholes and drains for proper disposal.
- Use only as much water as necessary for dust control, to avoid runoff.
- Catch drips from paving equipment that is not in use with pans or absorbent material placed under the machines. Dispose of collected material and absorbents properly.

Inspection

- Have designated personnel conduct inspections of parking facilities and stormwater conveyance systems associated with parking facilities on a regular basis.
- Inspect cleaning equipment/sweepers for leaks on a regular basis.

Training

- Provide regular training to field employees and/or contractors regarding cleaning of paved areas and proper operation of equipment.
- Train employees and contractors in proper techniques for spill containment and cleanup.

Spill Response and Prevention

- Keep your Spill Prevention Control and Countermeasure (SPCC) Plan up-to-date.
- Place a stockpile of spill cleanup materials where it will be readily accessible or at a central location.
- Clean up fluid spills immediately with absorbent rags or material.
- Dispose of spilled material and absorbents properly.

Other Considerations

Limitations related to sweeping activities at large parking facilities may include high equipment costs, the need for sweeper operator training, and the inability of current sweeper technology to remove oil and grease.

SC-43 Parking/Storage Area Maintenance

Requirements

Costs

Cleaning/sweeping costs can be quite large. Construction and maintenance of stormwater structural controls can be quite expensive as well.

Maintenance

- Sweep parking lot regularly to minimize cleaning with water.
- Clean out oil/water/sand separators regularly, especially after heavy storms.
- Clean parking facilities regularly to prevent accumulated wastes and pollutants from being discharged into conveyance systems during rainy conditions.

Supplemental Information

Further Detail of the BMP

Surface Repair

Apply concrete, asphalt, and seal coat during dry weather to prevent contamination from contacting stormwater runoff. Where applicable, cover and seal nearby storm drain inlets (with waterproof material or mesh) and manholes before applying seal coat, slurry seal, etc. Leave covers in place until job is complete and all water from emulsified oil sealants has drained or evaporated. Clean any debris from these covered manholes and drains for proper disposal. Only use only as much water as is necessary for dust control to avoid runoff.

References and Resources

California's Nonpoint Source Program Plan <http://www.swrcb.ca.gov/nps/index.html>

Clark County Storm Water Pollution Control Manual
<http://www.co.clark.wa.us/pubworks/bmpman.pdf>

King County Storm Water Pollution Control Manual <http://dnr.metrokc.gov/wlr/dss/spcm.htm>

Pollution from Surface Cleaning Folder. 1996. Bay Area Stormwater Management Agencies Association (BASMAA). <http://www.basmaa.org/>

Oregon Association of Clean Water Agencies. Oregon Municipal Stormwater Toolbox for Maintenance Practices. June 1998.

Santa Clara Valley Urban Runoff Pollution Prevention Program <http://www.scvurppp.org>

The Storm Water Managers Resource Center <http://www.stormwatercenter.net/>



Objectives

- Cover
- Contain
- Educate
- Reduce/Minimize

Description

As a consequence of its function, the stormwater conveyance system collects and transports urban runoff and stormwater that may contain certain pollutants. The protocols in this fact sheet are intended to reduce pollutants reaching receiving waters through proper conveyance system operation and maintenance.

Approach

Pollution Prevention

Maintain catch basins, stormwater inlets, and other stormwater conveyance structures on a regular basis to remove pollutants, reduce high pollutant concentrations during the first flush of storms, prevent clogging of the downstream conveyance system, restore catch basins' sediment trapping capacity, and ensure the system functions properly hydraulically to avoid flooding.

Suggested Protocols

Catch Basins/Inlet Structures

- Staff should regularly inspect facilities to ensure compliance with the following:
 - Immediate repair of any deterioration threatening structural integrity.
 - Cleaning before the sump is 40% full. Catch basins should be cleaned as frequently as needed to meet this standard.
 - Stenciling of catch basins and inlets (see SC34 Waste Handling and Disposal).

Targeted Constituents

Sediment	✓
Nutrients	
Trash	✓
Metals	
Bacteria	✓
Oil and Grease	
Organics	



- Clean catch basins, storm drain inlets, and other conveyance structures before the wet season to remove sediments and debris accumulated during the summer.
- Conduct inspections more frequently during the wet season for problem areas where sediment or trash accumulates more often. Clean and repair as needed.
- Keep accurate logs of the number of catch basins cleaned.
- Store wastes collected from cleaning activities of the drainage system in appropriate containers or temporary storage sites in a manner that prevents discharge to the storm drain.
- Dewater the wastes if necessary with outflow into the sanitary sewer if permitted. Water should be treated with an appropriate filtering device prior to discharge to the sanitary sewer. If discharge to the sanitary sewer is not allowed, water should be pumped or vacuumed to a tank and properly disposed. Do not dewater near a storm drain or stream.

Storm Drain Conveyance System

- Locate reaches of storm drain with deposit problems and develop a flushing schedule that keeps the pipe clear of excessive buildup.
- Collect and pump flushed effluent to the sanitary sewer for treatment whenever possible.

Pump Stations

- Clean all storm drain pump stations prior to the wet season to remove silt and trash.
- Do not allow discharge to reach the storm drain system when cleaning a storm drain pump station or other facility.
- Conduct routine maintenance at each pump station.
- Inspect, clean, and repair as necessary all outlet structures prior to the wet season.

Open Channel

- Modify storm channel characteristics to improve channel hydraulics, increase pollutant removals, and enhance channel/creek aesthetic and habitat value.
- Conduct channel modification/improvement in accordance with existing laws. Any person, government agency, or public utility proposing an activity that will change the natural (emphasis added) state of any river, stream, or lake in California, must enter into a Stream or Lake Alteration Agreement with the Department of Fish and Game. The developer-applicant should also contact local governments (city, county, special districts), other state agencies (SWRCB, RWQCB, Department of Forestry, Department of Water Resources), and Federal Corps of Engineers and USFWS.

Illicit Connections and Discharges

- Look for evidence of illegal discharges or illicit connections during routine maintenance of conveyance system and drainage structures:
 - Is there evidence of spills such as paints, discoloring, etc?

- Are there any odors associated with the drainage system?
- Record locations of apparent illegal discharges/illicit connections?
- Track flows back to potential dischargers and conduct aboveground inspections. This can be done through visual inspection of upgradient manholes or alternate techniques including zinc chloride smoke testing, fluorometric dye testing, physical inspection testing, or television camera inspection.
- Eliminate the discharge once the origin of flow is established.
- Stencil or demarcate storm drains, where applicable, to prevent illegal disposal of pollutants. Storm drain inlets should have messages such as “Dump No Waste Drains to Stream” stenciled next to them to warn against ignorant or intentional dumping of pollutants into the storm drainage system.
- Refer to fact sheet SC-10 Non-Stormwater Discharges.

Illegal Dumping

- Inspect and clean up hot spots and other storm drainage areas regularly where illegal dumping and disposal occurs.
- Establish a system for tracking incidents. The system should be designed to identify the following:
 - Illegal dumping hot spots
 - Types and quantities (in some cases) of wastes
 - Patterns in time of occurrence (time of day/night, month, or year)
 - Mode of dumping (abandoned containers, “midnight dumping” from moving vehicles, direct dumping of materials, accidents/spills)
 - Responsible parties
- Post “No Dumping” signs in problem areas with a phone number for reporting dumping and disposal. Signs should also indicate fines and penalties for illegal dumping.
- Refer to fact sheet SC-10 Non-Stormwater Discharges.

Training

- Train crews in proper maintenance activities, including record keeping and disposal.
- Allow only properly trained individuals to handle hazardous materials/wastes.
- Have staff involved in detection and removal of illicit connections trained in the following:
 - OSHA-required Health and Safety Training (29 CFR 1910.120) plus annual refresher training (as needed).

- OSHA Confined Space Entry training (Cal-OSHA Confined Space, Title 8 and Federal OSHA 29 CFR 1910.146).
- Procedural training (field screening, sampling, smoke/dye testing, TV inspection).

Spill Response and Prevention

- Investigate all reports of spills, leaks, and/or illegal dumping promptly.
- Clean up all spills and leaks using “dry” methods (with absorbent materials and/or rags) or dig up, remove, and properly dispose of contaminated soil.
- Refer to fact sheet SC-11 Spill Prevention, Control, and Cleanup.

Other Considerations (Limitations and Regulations)

- Clean-up activities may create a slight disturbance for local aquatic species. Access to items and material on private property may be limited. Trade-offs may exist between channel hydraulics and water quality/riparian habitat. If storm channels or basins are recognized as wetlands, many activities, including maintenance, may be subject to regulation and permitting.
- Storm drain flushing is most effective in small diameter pipes (36-inch diameter pipe or less, depending on water supply and sediment collection capacity). Other considerations associated with storm drain flushing may include the availability of a water source, finding a downstream area to collect sediments, liquid/sediment disposal, and prohibition against disposal of flushed effluent to sanitary sewer in some areas.
- Regulations may include adoption of substantial penalties for illegal dumping and disposal.
- Local municipal codes may include sections prohibiting discharge of soil, debris, refuse, hazardous wastes, and other pollutants into the storm drain system.

Requirements

Costs

- An aggressive catch basin cleaning program could require a significant capital and O&M budget.
- The elimination of illegal dumping is dependent on the availability, convenience, and cost of alternative means of disposal. The primary cost is for staff time. Cost depends on how aggressively a program is implemented. Other cost considerations for an illegal dumping program include:
 - Purchase and installation of signs.
 - Rental of vehicle(s) to haul illegally-disposed items and material to landfills.
 - Rental of heavy equipment to remove larger items (e.g., car bodies) from channels.
 - Purchase of landfill space to dispose of illegally-dumped items and material.

- Methods used for illicit connection detection (smoke testing, dye testing, visual inspection, and flow monitoring) can be costly and time-consuming. Site-specific factors, such as the level of impervious area, the density and ages of buildings, and type of land use will determine the level of investigation necessary.

Maintenance

- Two-person teams may be required to clean catch basins with vacor trucks.
- Teams of at least two people plus administrative personnel are required to identify illicit discharges, depending on the complexity of the storm sewer system.
- Arrangements must be made for proper disposal of collected wastes.
- Technical staff are required to detect and investigate illegal dumping violations.

Supplemental Information

Further Detail of the BMP

Storm Drain Flushing

Flushing is a common maintenance activity used to improve pipe hydraulics and to remove pollutants in storm drainage systems. Flushing may be designed to hydraulically convey accumulated material to strategic locations, such as an open channel, another point where flushing will be initiated, or the sanitary sewer and the treatment facilities, thus preventing resuspension and overflow of a portion of the solids during storm events. Flushing prevents “plug flow” discharges of concentrated pollutant loadings and sediments. Deposits can hinder the designed conveyance capacity of the storm drain system and potentially cause backwater conditions in severe cases of clogging.

Storm drain flushing usually takes place along segments of pipe with grades that are too flat to maintain adequate velocity to keep particles in suspension. An upstream manhole is selected to place an inflatable device that temporarily plugs the pipe. Further upstream, water is pumped into the line to create a flushing wave. When the upstream reach of pipe is sufficiently full to cause a flushing wave, the inflated device is rapidly deflated with the assistance of a vacuum pump, thereby releasing the backed up water and resulting in the cleaning of the storm drain segment.

To further reduce impacts of stormwater pollution, a second inflatable device placed well downstream may be used to recollect the water after the force of the flushing wave has dissipated. A pump may then be used to transfer the water and accumulated material to the sanitary sewer for treatment. In some cases, an interceptor structure may be more practical or required to recollect the flushed waters.

It has been found that cleansing efficiency of periodic flush waves is dependent upon flush volume, flush discharge rate, sewer slope, sewer length, sewer flow rate, sewer diameter, and population density. As a rule of thumb, the length of line to be flushed should not exceed 700 feet. At this maximum recommended length, the percent removal efficiency ranges between 65-75% for organics and 55-65% for dry weather grit/inorganic material. The percent removal efficiency drops rapidly beyond that. Water is commonly supplied by a water truck, but fire hydrants can also supply water. To make the best use of water, it is recommended that reclaimed water be used or that fire hydrant line flushing coincide with storm sewer flushing.

References and Resources

California's Nonpoint Source Program Plan <http://www.swrcb.ca.gov/nps/index.html>

Clark County Storm Water Pollution Control Manual
<http://www.co.clark.wa.us/pubworks/bmpman.pdf>

Ferguson, B.K. 1991. Urban Stream Reclamation, p. 324-322, Journal of Soil and Water Conservation.

King County Storm Water Pollution Control Manual <http://dnr.metrokc.gov/wlr/dss/spcm.htm>

Oregon Association of Clean Water Agencies. Oregon Municipal Stormwater Toolbox for Maintenance Practices. June 1998.

Santa Clara Valley Urban Runoff Pollution Prevention Program <http://www.scvurppp.org>

The Storm Water Managers Resource Center <http://www.stormwatercenter.net>

United States Environmental Protection Agency (USEPA). 2002. Pollution Prevention/Good Housekeeping for Municipal Operations Storm Drain System Cleaning. On line:
http://www.epa.gov/npdes/menuofbmps/poll_16.htm

Appendix 4 LID BMPs

Appendix 4.1 MaxWell IV Drywell Information

The **MaxWell® IV**, as manufactured and installed exclusively by Torrent Resources Incorporated, is the industry standard for draining landscaped developments and paved areas. This patented system incorporates the latest refinements in pre-treatment technology.

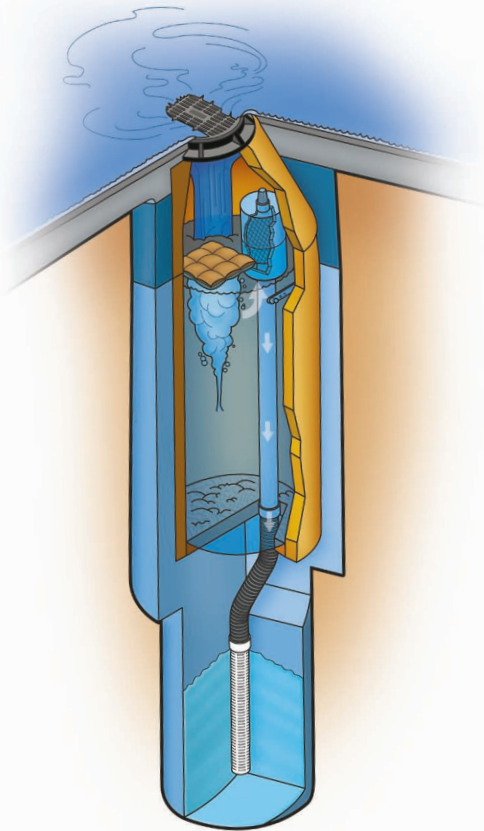

PROVEN DESIGN

Since 1974, nearly 65,000 MaxWell® Systems have proven their value as a cost-effective solution in a wide variety of drainage applications. They are accepted by state and municipal agencies and are a standard detail in numerous drainage manuals.

ADVANCED PRE-TREATMENT

Industry research, together with Torrent Resources' own experience, have shown that initial storm drainage flows have the greatest impact on system performance. This "first flush" occurs during the first few minutes of runoff, and carries the majority of sediment and debris. This results in the need for effective processing

of runoff from landscaped and paved surfaces. In the **MaxWell® IV**, preliminary treatment is provided through collection and separation in a deep, large-volume chamber where silt and other heavy particles settle to the bottom. The standard MaxWell IV System has over 1,500 gallons of capacity to contain sediment and debris carried by incoming water. Floating trash, paper, pavement oil, etc. are effectively stopped by the **PureFlo®** Debris Shield on top of the overflow pipe. Water is drained from the system by rising up to the top of the overflow pipe and under the Debris Shield. The solid metal shields are equipped with an internal screen to filter suspended matter and are vented to prevent siphoning of floating surface debris. The drainage assembly returns the cleaned water into the surrounding soil through the **FloFast®** Drainage Screen.

ABSORBENT TECHNOLOGY

The MaxWell IV settling chamber is equipped with an absorbent sponge to provide prompt removal of pavement oils. These floating pillow-like devices are 100% water repellent and literally wick petrochemical compounds from the water. Each sponge has a capacity of up to 128 ounces to accommodate effective, long-term treatment. The absorbent is completely inert and will safely remove runoff constituents down to rainbow sheens that are typically no more than one molecule thick.

SECURITY FEATURES

MaxWell IV Systems include bolted, theft-deterrent, cast iron gratings and covers as standard security features. Special inset castings that are resistant to loosening from accidental impact are available for use in landscaped applications. Machined mating surfaces and "Storm Water Only" wording are standard.

THE MAXWELL FIVE-YEAR WARRANTY

Innovative engineering, quality materials and exacting construction are standard with every MaxWell System designed, manufactured and installed by Torrent Resources Incorporated. The MaxWell Drainage System Warranty is the best in the industry and guarantees against failures due to workmanship or materials for a period of five years from date of completion.

MAXWELL® IV DRAINAGE SYSTEM DETAIL AND SPECIFICATIONS

ITEM NUMBERS

1. Manhole Cone - Modified Flat Bottom.
2. Moisture Membrane - 6 Mil. Plastic. Applies only when native material is used for backfill. Place membrane securely against eccentric cone and hole sidewall.
3. Bolted Ring & Grate - Diameter as shown. Clean cast iron with wording "Storm Water Only" in raised letters. Bolted in 2 locations and secured to cone with mortar. Rim elevation $\pm 0.02'$ of plans.
4. Graded Basin or Paving (by Others).
5. Compacted Base Material - 1-Sack Slurry except in landscaped installations with no pipe connections.
6. PureFlo® Debris Shield - Rolled 16 ga. steel X 24" length with vented anti-siphon and Internal .265" Max. SWO flattened expanded steel screen X 12" length. Fusion bonded epoxy coated.
7. Pre-cast Liner - 4000 PSI concrete 48" ID. X 54" OD. Center in hole and align sections to maximize bearing surface.
8. Min. 6' \emptyset Drilled Shaft.
9. Support Bracket - Formed 12 Ga. steel. Fusion bonded epoxy coated.
10. Overflow Pipe - Sch. 40 PVC mated to drainage pipe at base seal.
11. Drainage Pipe - ADS highway grade with TRI-A coupler. Suspend pipe during backfill operations to prevent buckling or breakage. Diameter as noted.
12. Base Seal - Geotextile or concrete slurry.
13. Rock - Washed, sized between 3/8" and 1-1/2" to best complement soil conditions.
14. FloFast® Drainage Screen - Sch. 40 PVC 0.120" slotted well screen with 32 slots per row/ft. Diameter varies 120" overall length with TRI-B coupler.
15. Min. 4' \emptyset Shaft - Drilled to maintain permeability of drainage soils.
16. Fabric Seal - U.V. resistant geotextile - to be removed by customer at project completion.
17. Absorbent - Hydrophobic Petrochemical Sponge. Min. to 128 oz. capacity.
18. Freeboard Depth Varies with inlet pipe elevation. Increase settling chamber depth as needed to maintain all inlet pipe elevations above overflow pipe inlet.
19. Optional Inlet Pipe (Maximum 4", by Others). Extend moisture membrane and compacted base material or 1 sack slurry backfill below pipe invert.

The referenced drawing and specifications are available on CAD either through our office or web site. This detail is copyrighted (2004) but may be used as is in construction plans without further release. For information on product application, individual project specifications or site evaluation, contact our Design Staff for no-charge assistance in any phase of your planning.

CALCULATING MAXWELL IV REQUIREMENTS

The type of property, soil permeability, rainfall intensity and local drainage ordinances determine the number and design of Maxwell Systems. For general applications draining retained stormwater, use one standard **MaxWell IV** per the instructions below for up to 3 acres of landscaped contributory area, and up to 1 acre of paved surface. For larger paved surfaces, subdivision drainage, nuisance water drainage, connecting pipes larger than 4" \emptyset from catch basins or underground storage, or other demanding applications, refer to our **MaxWell® Plus** System. For industrial drainage, including gasoline service stations, our **Envibro® System** may be recommended. For additional considerations, please refer to "Design Suggestions For Retention And Drainage Systems" or consult our Design Staff.

COMPLETING THE MAXWELL IV DRAWING

To apply the **MaxWell IV** drawing to your specific project, simply fill in the blue boxes per instructions below. For assistance, please consult our Design Staff.

ESTIMATED TOTAL DEPTH

The Estimated Total Depth is the approximate depth required to achieve 10 continuous feet of penetration into permeable soils. Torrent utilizes specialized "crowd" equipped drill rigs to penetrate difficult, cemented soils and to reach permeable materials at depths up to **180 feet**. Our extensive database of drilling logs and soils information is available for use as a reference. Please contact our Design Staff for site-specific information on your project.

SETTLING CHAMBER DEPTH

On MaxWell IV Systems of over 30 feet overall depth and up to 0.25cfs design rate, the **standard** Settling Chamber Depth is **18 feet**. For systems exposed to greater contributory area than noted above, extreme service conditions, or that require higher design rates, chamber depths up to 25 feet are recommended.

OVERFLOW HEIGHT

The Overflow Height and Settling Chamber Depth determine the effectiveness of the settling process. The higher the overflow pipe, the deeper the chamber, the greater the settling capacity. For normal drainage applications, an overflow height of **13 feet** is used with the standard settling chamber depth of **18 feet**. Sites with higher design rates than noted above, heavy debris loading or unusual service conditions require greater settling capacities

TORRENT RESOURCES INCORPORATED

1509 East Elwood Street, Phoenix Arizona 85040-1391
phone 602-268-0785 fax 602-268-0820
Nevada 702-366-1234

AZ Lic. ROC070465 A, ROC047067 B-4; ADWR 363
CA Lic. 528080 A, C-42, HAZ - NV Lic. 0035350 A - NM Lic. 90504 GF04

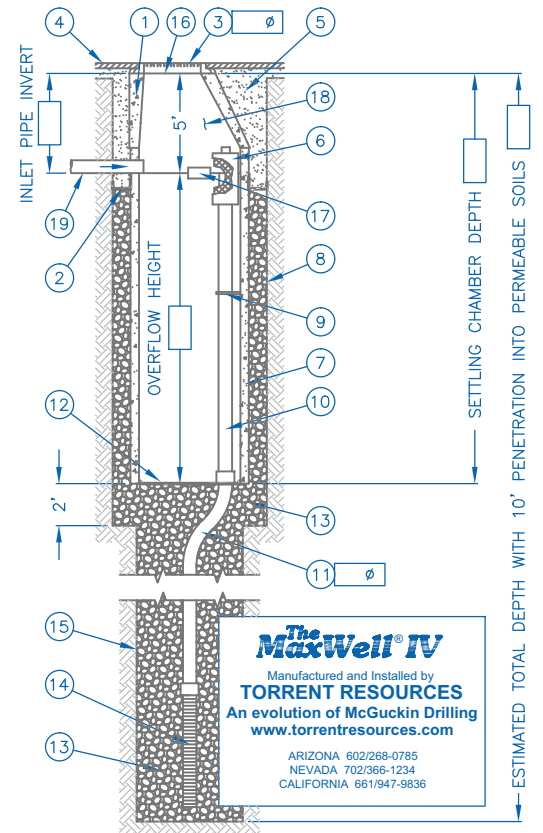

AZ Lic. ROC070465 A, ROC047067 B-4, ADWR 363
CA Lic. 528080 A, C-42, HAZ
NV Lic. 0035350 A - NM Lic. 90504 GF04
U.S. Patent No. 4,923,330 - TM Trademark 1974, 1990, 2004

DRAINAGE PIPE

This dimension also applies to the **PureFlo®** Debris Shield, the **FloFast®** Drainage Screen, and fittings. The size selected is based upon system design rates, soil conditions, and the need for adequate venting. Choices are 6", 8", or 12" diameter. Refer to "Design Suggestions for Retention and Drainage Systems" for recommendations on which size best matches your application.

BOLTED RING & GRATE

Standard models are quality cast iron and available to fit 24" \emptyset or 30" \emptyset manhole openings. All units are bolted in two locations with wording "Storm Water Only" in raised letters. For other surface treatments, please refer to "Design Suggestions for Retention and Drainage Systems."

INLET PIPE INVERT

Pipes up to 4" in diameter from catch basins, underground storage, etc. may be connected into the settling chamber. Inverts deeper than 5 feet will require additional settling chamber depth to maintain effective overflow height.

TORRENT RESOURCES (CA) INCORPORATED

phone 661-947-9836
CA Lic. 886759 A, C-42

www.TorrentResources.com

An evolution of McGuckin Drilling

The watermark for drainage solutions.®





The watermark for drainage solutions.®



INDUSTRY SERVICES

SITE DRAINAGE SYSTEMS

TECHNICAL ANALYSIS

RECHARGE SYSTEMS

ENVIRONMENTAL APPS.

DRAINAGE RENOVATION

DRAINAGE MAINTENANCE

COMPANY OVERVIEW

ONLINE RESOURCES



DRAINAGE MAINTENANCE

With over thirty years of experience to draw on, Torrent Resources records clearly show that utilizing regular inspection and cleaning procedures can significantly enhance the service-life and performance of the drainage systems it installs. *Maintenance Data Sheets* accompany all MaxWell and Envibro Systems at the time of completion that provide operational information and instructions for inspection and service.

As a benefit to all MaxWell and Envibro owners, Torrent offers a full range of maintenance programs to protect the investment made in its drainage systems. With thorough knowledge and experience to analyze the operational and structural aspects of our patented products, we can effectively accomplish these basic, yet important services.

Torrent can provide Preventive Maintenance Programs that are tailored for your site including full service contracts. These services would include a preliminary inspection of the settling chambers and internal components and an assessment of the site drainage to insure that the system meets operational guidelines. A written report is provided at the completion of each inspection.

MaxWell system cleaning is accomplished with truck mounted hydro-vactor equipment, utilizing water and air to dislodge and remove debris and sediment deposits. All chambers, inlets, connecting piping and catch basins are cleaned with the contents evacuated and transported off-site for disposal. Geotextile fabric base seals and hydrophobic petrochemical sponges are removed and replaced in each chamber. Inlet grates and covers are then re-installed and re-secured with existing locking devices.

Envibro system cleaning utilizes similar maintenance equipment. Servicing includes removal of debris from the trash basket under the collector grate inlet, hydro-vactoring all chambers and cleaning of silt filters. All, inlets, connecting piping and catch basins are cleaned as well with the contents evacuated and transported off-site for disposal. Inspection of the Imbiber Beads® Drain Field assembly is also included in standard maintenance. All hydrophobic absorbents blankets are replaced and inlet grates and covers are re-installed and re-secured with existing locking devices.

Under normal operation, Envibro cleaning is recommended annually or following heavy rainfalls and high loading of the system with foreign trash and debris. Should a spill or other discharge occur, complete service of the systems and replacement of activated Imbiber Beads® Drain Field assembly is normally required.

Below is a list of our Drainage Maintenance services:
Preventative Maintenance
Service Contracts
Drywell Cleaning

Imbiber Beads® is a registered Trademark of Imbibitive Technologies Corporation



"Sun State Builders has had the privilege of working with Torrent Resources for several years. We find their work to be of excellent quality and their customer service is superior. We look forward to utilizing their services in all of our projects in the future."

Andrea Vallas
Assistant Project Manager
Sun State Builders

MaxWell IV Drywell

The Operation and Maintenance Program will include the following key components:

1. Inspection Procedures:

The settling chambers and internal components of the unit will be inspected regularly. Additionally, an assessment of the site drainage will be conducted to insure that the system meets operation guidelines. The visual inspection will ascertain that the unit is functioning properly (no blockages or obstructions to inlet and/or infiltration chamber), measuring the amount of solid materials, fine sediment, and floating trash and debris within the chamber. Schedules for inspections and cleanout will be based on storm events and pollutant accumulation due to failure of upstream pre-treatment device. During the rainfall season, the unit will be inspected at least once every 30 days. Accumulation of sediment and floatable material captured by the MaxWell IV will be recorded in a maintenance log.

2. Cleanout Procedures:

Truck mounted hydro-vactor equipment will be used to clean the system utilizing water and air to dislodge and remove debris and sediment deposits. All chambers, inlets, connecting piping and catch basins are cleaned and the contents discharged. The accumulated contents are transported off-site for disposal. Within each chamber, geotextile fabric base seals and hydrophobic petrochemical sponges are removed and replaced. Inlet grates and covers are re-installed and then re-secured with the existing locking devices.

3. Stenciling:

Legibility of stencils and/or signs at all storm drain inlets and catch basins within the project area must be maintained at all time.

4. Maintenance Log:

Keep on-site a log of all inspections and maintenance performed on the MaxWell IV.

Appendix 4.2 Aqua-Swirl Information

AQUA-SWIRL ™

HYDRODYNAMIC SEPARATION



- 1** Floatable debris, oils, and grease enter the storm drain
- 2** Contaminated water enters the Aqua-Swirl™ via the main conveyance storm pipe
- 3** The Aqua-Swirl™ is constructed of durable, lightweight, and high performance materials
- 4** Vortex separation is used to remove the gross sediment, floating debris and free-oil
- 5** Independent validation for TSS removal into sensitive receiving waters

INNOVATING GOOD CLEAN WATER

AQUA-SWIRL

Pipe Connections

- Systems are designed with custom inlet / outlet diameters at various configuration angles
- Inlet / outlet stubouts are provided for easy coupling

Inspection & Maintenance

- AquaShield™ offers an extensive maintenance program that ensures system performance efficiency
- Download manuals from the on-line system catalog

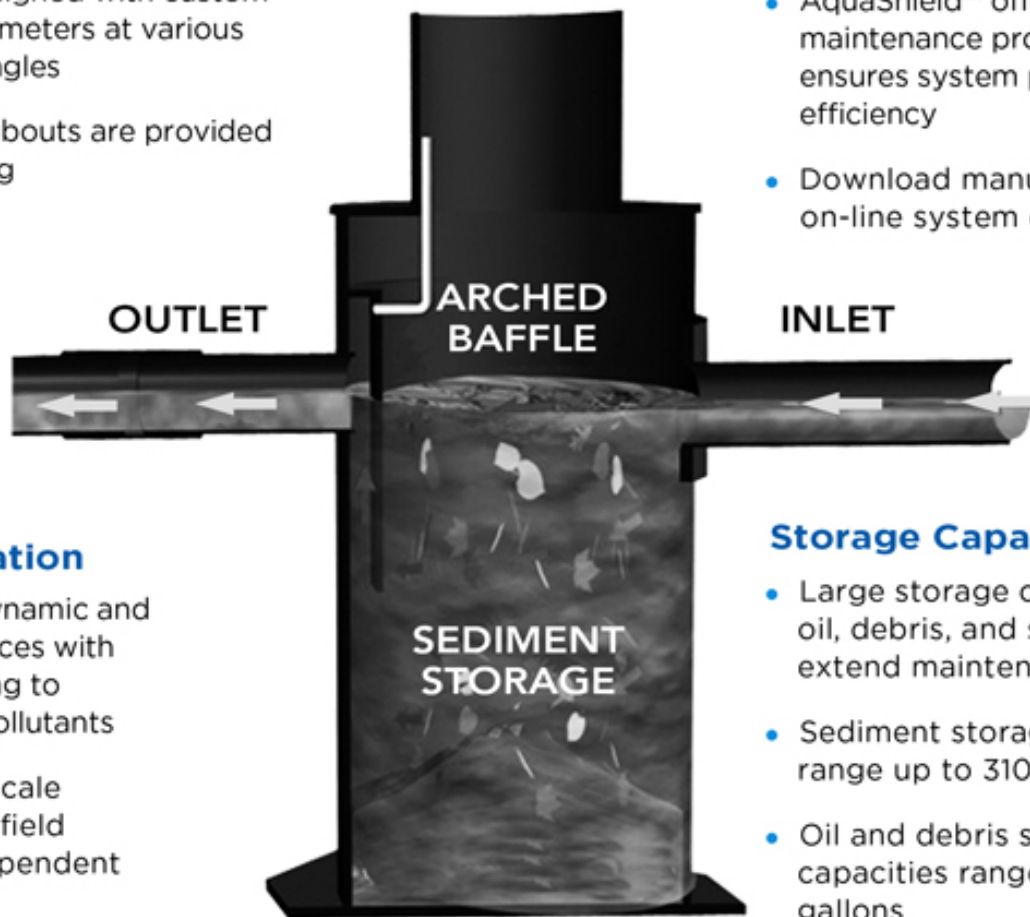

Vortex Separation

- Utilizes hydrodynamic and gravitational forces with quiescent settling to remove gross pollutants
- Extensive full-scale laboratory and field testing by independent third parties

Storage Capacities

- Large storage capacities for oil, debris, and sediment extend maintenance cycles
- Sediment storage capacities range up to 310 ft³
- Oil and debris storage capacities range up to 1986 gallons

Bypass

- Systems are designed to treat water quality flow rates and bypass peak storm events
- Internal and external bypass configurations are available

Installation Benefits

- Quick and simple installation, resulting in measurable project cost savings
- H₂O loading capabilities
- Small footprint design reduces excavation costs
- Lightweight and durable construction
- Lifting supports & cables provided

Aqua-Swirl™ System

- Provides customized solutions for project specific requirements
- Systems designed for specific water quality treatment flows
- Modular sizes from 2.5 - 13 ft diameters with attached risers to finish grade
- On-line project and system design tool at <http://pda.aquashieldinc.com>

STATEMENT OF QUALIFICATIONS

AQUA-SWIRL® STORMWATER TREATMENT SYSTEM



January 2017



AquaShield™, Inc.
2733 Kanasita Drive
Suite 111
Chattanooga, Tennessee 37343
(888) 344-9044
Fax (423) 826-2112
www.aquashieldinc.com

Aqua-Swirl® Statement of Qualifications

Table of Contents

	<u>Page</u>
1.0 Overview	1
1.1 Mode of Operation	1
1.2 General Equipment Design	2
1.3 Range of Operating Conditions	3
1.4 Contaminants to be Treated	3
1.5 Inspection and Maintenance	4
2.0 Construction Materials	5
3.0 Use Applications	5
4.0 Performance Testing	5
4.1 Laboratory Testing	6
4.2 Field Testing	6
5.0 Regulatory Approvals	7
5.1 States and Provinces	8
5.2 State Departments of Transportation	9
5.3 Regional Planning Authorities	9
5.4 Counties	9
5.5 Municipalities	10
6.0 Limited Warranty	10

AQUA-SWIRL[®] STATEMENT OF QUALIFICATIONS

1.0 OVERVIEW

1.1 Mode of Operation

The Aqua-Swirl[®] Stormwater Treatment System (Aqua-Swirl[®]) is a custom engineered, post-construction flow-through structure designed to remove sediment, floating debris, trash and free-floating oil by utilizing hydrodynamic vortex-enhanced separation (Figure 1). The United States patent, “Drainwater Treatment System for Use in a Horizontal Passageway,” U.S. Patent No. 6,190,545 currently applies to the Aqua-Swirl[®].

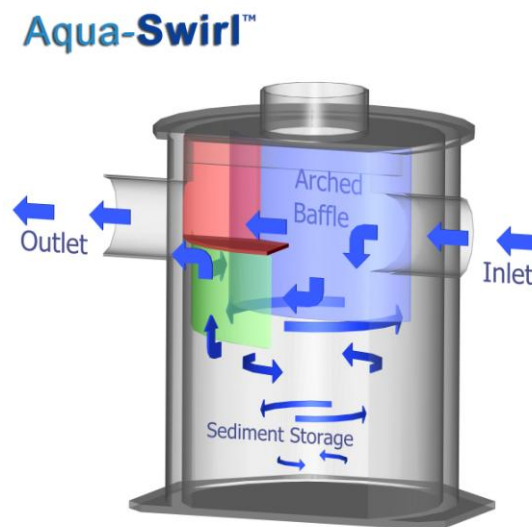

Figure 1. Diagram of Aqua-Swirl[®] Stormwater Treatment System showing the circular flow of water through the system which encourages settling of sediment and retention of floatable materials.

Aqua-Swirl[®] technology is a rapid or high flow rate device that has no moving parts and operates on gravity flow or movement of the stormwater runoff entering the structure. Operation begins when stormwater enters the Aqua-Swirl[®] by means of its tangential inlet pipe thereby inducing a circular (swirl or vortex) flow pattern. The diameter of the swirl chamber represents the effective treatment area of the device. Both sediment capture and sediment storage is accomplished within the swirl chamber. A combination of gravitational and hydrodynamic drag forces results in solids dropping out of the flow and migrating to the center of the swirl chamber where velocities are the lowest. Flow circulates downward where water exits the swirl chamber by flowing underneath and upward behind the arched inner baffle. The top of the baffle is sealed across the treatment channel to eliminate floatable pollutants from escaping the swirl chamber. A vent pipe is extended up the riser to expose the backside of the baffle to atmospheric conditions, thus preventing a siphon from forming at the bottom of the baffle. Sediment is stored at the base of the swirl chamber while floatables remain captured with the treatment area.

1.2 General Equipment Design

A unique quality of the Aqua-Swirl® is its modular design which allows for faster and simpler installation on new construction or retrofit projects for existing storm drainage structures. The Aqua-Swirl® can operate in either an offline or online configuration. Offline designs rely on the use of a separate external bypass structures. The diversion structure directs only the designed water quality treatment flow (WQ_f) to the unit whereby flows in excess of the WQ_f bypass the Aqua-Swirl®. Online Aqua-Swirl® systems utilize an internal bypass design (models designated as “BYP”) to allow for the conveyance of both the WQ_f and the bypass flow volumes. Aqua-Swirl® systems provide for equal invert elevations for both the inlet and outlet pipe stubouts. No external driving head is needed for operation other than that needed to convey flow according to the site design.

The diameter of the swirl chamber’s treatment area varies from 2.5 to 13 feet depending on model size necessary to treat the WQ_f . Table 1 summarizes the available Aqua-Swirl® models, swirl chamber inner diameters, and oil/debris and sediment storage capacities.

Table 1. Aqua-Swirl® Models and Storage Capacities

Aqua-Swirl® Model	Swirl Chamber Inner Diameter (ft)	Water Quality Treatment Flow Rates (cfs)	Oil/Debris Storage Capacity (gal)	Sediment Storage Capacity (ft³)
AS-2	2.5	1.1	37	10
AS-3	3.3	1.8	110	20
AS-4	4.3	3.2	190	32
AS-5	5.0	4.4	270	45
AS-6	6.0	6.3	390	65
AS-7	7.0	8.6	540	90
AS-8	8.0	11.2	710	115
AS-9	9.0	14.2	910	145
AS-10	10.0	17.5	1,130	180
AS-11	11.0	21.2	1,422	222
AS-12	12.0	25.2	1,698	270
AS-13	13.0	29.6	1,986	310
AS-XX		Custom*		

* Custom designs to meet site-specific criteria, can include multiple (twin) units for increased flow and materials storage capacity.

The Aqua-Swirl® is also designed so that it can easily be used for retrofit applications. When the invert of the inlet and outlet pipe of the Aqua-Swirl® is positioned at the same elevation the unit can easily be connected directly to the existing storm conveyance drainage system.

Shop drawings and any other pertinent design drawings are provided on a site-specific basis. Additional information on custom designs and detail drawings can be provided on request for each of the construction materials available for the Aqua-Swirl® (see Section 2.0 construction materials). Given that Aqua-Swirl® systems can be custom designed, a number of offline configurations can be utilized. AquaShield™ can assist with facility layouts to minimize an Aqua-Swirl® footprint.

The Aqua-Swirl® has been designed and fabricated as a modular unit with no moving parts or on-site assembly required. Since the system is fabricated from high performance, lightweight and durable construction materials, the device can be installed without the use of a crane. Lifting supports are provided to allow easy offloading and installation with a backhoe or trackhoe. In addition, manufactured stubouts for the inlet and outlet piping are provided which allows the installer to simply attach the Aqua-Swirl® directly to the main conveyance storm pipe with Fernco™ or equivalent couplings. Pick weights are available on request.

All Aqua-Swirl® systems are supplied with octagonal base plates which typically extend a minimum of six inches beyond the outside diameter of the swirl chamber. The function of the base plate extension is to provide additional surface area to counter any buoyant force exerted on the system. The forces created on the base plate by the weight of the surrounding fill material offsets the buoyant force generated within the system. If needed, concrete can be poured directly onto the base plate to provide additional resistive force. AquaShield™ routinely performs buoyancy calculations for all system installations.

1.3 Range of Operating Conditions

Aqua-Swirl® systems have been designed to provide water quality treatment at a range of flow rates. AquaShield™ actively assists design engineers to properly size a system to meet site-specific water quality design storm. It is important to consider that when two identical Aqua-Swirl® units are installed in parallel the operating range can double from that of a single unit such that exceptionally large flow rates can be effectively treated.

1.4 Contaminants to be Treated

The primary waterborne contaminants of concern to be treated by the Aqua-Swirl® include:

- Suspended Sediment (commonly referred to as Total Suspended Solids, TSS)
- Trash/Debris
- Free-floating oil

The quantities of the COCs to be treated are based on site-specific pollutant loading factors. While the Aqua-Swirl® is not specifically designed to function in lieu of an oil-water separator, the device still provides treatment against free floating oil when conditions allow.

1.5 Inspection and Maintenance

A comprehensive Aqua-Swirl® Inspection and Maintenance Manual is provided for each site delivery for end users to understand system operations and track and document system inspection and maintenance cycles. AquaShield™ recommends that periodic Aqua-Swirl® system inspections be performed to determine whether the disposal of captured material is needed to ensure proper operation of the treatment system. It is important to keep in mind that *all* stormwater control measures (SCMs), including manufactured treatment devices (MTDs), require some degree of maintenance. Maintenance cycles are ultimately dependent on site-specific pollutant loading conditions.

Upon installation and during construction, AquaShield™ recommends that an Aqua-Swirl® treatment system be inspected every three months and the system be cleaned as needed. A typical maintenance event for the cleaning of the swirl chamber can be accomplished with a vacuum truck without the need to enter the chamber. The Aqua-Swirl® should be inspected and cleaned at the end of construction regardless of whether it has reached its capacity for sediment or oil storage. During the first year post-construction, the Aqua-Swirl® should again be inspected every three months and cleaned as needed. AquaShield™ recommends that the system be inspected and cleaned once annually regardless of whether it has reached its sediment or floatable pollutant storage capacity. For the second and subsequent years post-construction, the Aqua-Swirl® can be inspected and cleaned once annually if the system did not reach full sediment or floatable pollutant capacity in the first year post-construction. If the Aqua-Swirl® reached full sediment or floatable pollutant capacity in less than 12 months in the first year post-construction, the system should be inspected once every six months and cleaned as needed. AquaShield™ further recommends that all external bypass structures (divergent and convergent) should be inspected whenever an inspection and maintenance event is performed. These structures can adversely affect performance and functionality if left unchecked.

Essential elements of a swirl chamber inspection include observing floating materials and measuring the accumulated sediment at the base of the swirl chamber. These two activities can be performed at the ground surface (for a typical subsurface installation) and there is no need to enter the device. Provided that there are no significant access restrictions to the facility, it is considered that a system inspection should not exceed one half hour. A typical maintenance event includes the vacuuming and disposal of floatable pollutants and sediment from the swirl concentrator. Cleaning of the swirl chamber is often accomplished by use of a vacuum truck. It is estimated that the on-site activities for maintenance should not exceed one hour and can be performed by a one or two man crew. AquaShield™ recommends that if entry to the swirl chamber is necessary for any reason, then confined space entry techniques should be followed.

Proper health and safety protocols should be followed during all inspection and maintenance events. AquaShield™ recommends that all materials removed during the maintenance process be handled and disposed in accordance with all applicable federal, state and local guidelines. Depending on the influent pollutant characteristics of the system drainage area, it may be appropriate to perform Toxicity Characteristics Leaching Procedure (TCLP) analyses on representative samples of the removed material to ensure that the handling and disposition of materials complies with all applicable environmental regulations.

2.0 CONSTRUCTION MATERIALS

The Aqua-Swirl® is available using construction materials of either High Density Polyethylene (HDPE) or Polymer Coated Steel (PCS). Unique site conditions may require deviations to standard installation specifications. It is recommended that AquaShield™ be contacted prior to extraordinary installations to determine the extent to which any deviation, if possible, can be made to ensure that the integrity, functionality and product warranty of the device is maintained. Both HDPE and PCS provide high structural integrity for both long term durability and traffic loading conditions. Material specifications can be provided on request.

3.0 USE APPLICATIONS

Aqua-Swirl® technology can be applied to a wide variety of land uses and facilities. Common system applications include, but are not limited to, the following types of settings:

- Retail/Commercial Developments
- New and Existing Industrial Facilities
- Highway Construction
- Transportation facilities
- Watershed Protection
- Redevelopment/Retrofit Sites
- Government Facilities
- Military Installations, Bases and Berthing Wharfs
- Vehicle and Equipment Wash Rack Areas
- Fueling Centers and Convenience Stores
- Fast Food Restaurants
- Office Complexes
- Religious Centers
- Educational Facilities
- Residential Developments (single and multi-family)
- Coastal Zone Management Communities
- Drinking Water Well-head Protection Areas

Thousands of Aqua-Swirl® systems have been installed throughout the United States including the Commonwealth of Puerto Rico and the Territory of Guam. Aqua-Swirl® systems are also installed in Brazil, Canada, Hong Kong, India, the Middle East, Russia, South Korea and United Kingdom. Climatic conditions for Aqua-Swirl® installations range anywhere from sub-arctic (e.g., central Alaska) to sub-tropical locales. Information concerning domestic and international projects can be provided on request.

4.0 PERFORMANCE TESTING

The Aqua-Swirl® has completed comprehensive, independent full scale model testing in both laboratory and field settings. Summaries of both testing programs are provided in the following two sections.

4.1 Laboratory Testing

Independent performance testing of an Aqua-Swirl® Model AS-3 was conducted by the Department of Civil and Environmental Engineering at Tennessee Tech University (TTU), Cookeville and is described in the findings report, *Laboratory Evaluation of TSS Removal Efficiency for Aqua-Swirl® Concentrator Stormwater Treatment System*. The test parameters included loading rates, sediment concentrations, specific gravity, head loss, and particle size distribution. The test sediment was OK-110 manufactured by U.S. Silica, having a specific gravity of 2.65. The test material has a particle size range of approximately 50 to 150 microns (μm), representing the finest fraction of sand particulate. The test sediment manufacturer reports a median (d_{50}) particle size of 110 μm . However, other independent laboratory-specific testing programs performed in association with Aqua-Swirl® product development actually demonstrated a d_{50} of 90 to 95 μm . Note that OK-110 is no longer manufactured due to the manufacturer's inability to consistently meet the product specification.

Total suspended solids (TSS) concentrations were determined by the Suspended Sediment Concentration (SSC) analytical method consistent with ASTM D3977. The SSC method differs from the commonly cited TSS analytical method, EPA 2540D (formerly EPA 160.2) such that the SSC analysis is a whole sample TSS procedure. The analytical results of influent and effluent sample pair concentrations were used to calculate SSC removal efficiencies for each run at the target loading rates and concentrations. This study concluded that Aqua-Swirl® achieves an SSC removal efficiency of 91% on a net annual basis.

The results of this laboratory testing program have been independently verified by the New Jersey Corporation for Advanced Technology (NJCAT). The Washington State Department of Ecology has also assigned the General Use Level Designation (GULD) for Pretreatment (TSS) for the Aqua-Swirl®.

4.2 Field Testing

An Aqua-Swirl® Model AS-5 completed a 27 month independent field testing program in accordance with the Technology Acceptance Reciprocity Partnership (TARP) Tier II Field Testing Protocol. A total of 18 storms and 15.16 inches of rain were sampled between March 2009 and June 2011, demonstrating that the Aqua-Swirl® achieved 86% and 87% TSS and SSC removal efficiency, respectively. AECOM of Philadelphia, Pennsylvania served as the independent field testing organization. The test site is an asphalt covered parking lot with landscaped areas at the urban retail center in Silver Spring, Maryland (metro Washington D.C.). All samples were collected using ISCO autosamplers positioned at the influent and effluent pipe connections. ISCO area-velocity modules were used to gauge influent and effluent flow conditions. Suspended sediment analyses were performed by both the TSS and SSC Methods as cited above. Particle size distribution (PSD) was determined by serial filtration. Average influent PSD data indicates that 86% of the particulate is $<125 \mu\text{m}$ and 72% of the particulate is silt (1.5 to 63 μm). The test site particulate is classified as a clay loam textured sediment. The target NJDEP PSD is to exhibit a particulate range of 1.0 to 1,000 μm and a d_{50} of 67 μm . Figure 1 illustrates the influent PSD curve for the AS-5 and includes the NJDEP PSD standard. All field test analyses were performed by Test America, Inc. of Burlington, Vermont, a NELAP and New Jersey certified facility.

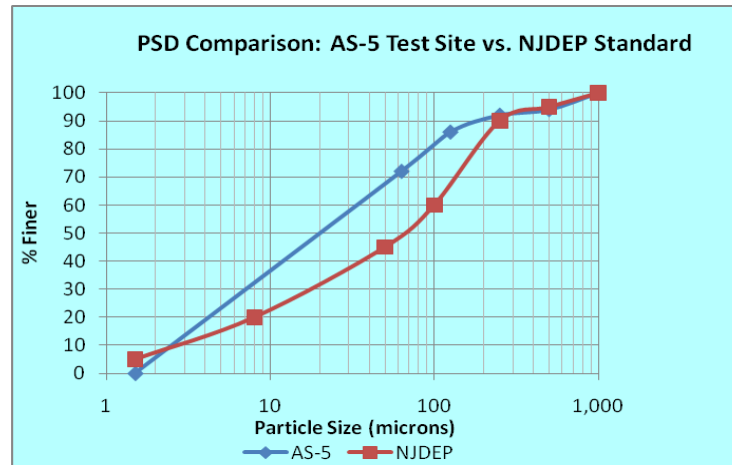

Figure 2. Particle size distribution for AS-5 Field test versus NJDEP laboratory test sediment particulate distribution.

Table 2 summarizes TSS and SSC removal efficiencies, storm durations, storm sizes, peak intensities, peak loading rates and percentage TVSS of TSS. Cumulative average sediment removal efficiencies for TSS and SSC are 86 and 87%, respectively. Cumulative average influent TSS and SSC concentrations are 132 and 145 mg/L, respectively. Storm sizes range from 0.11 to 4.4 inches with storm intensities ranging from 0.15 to 5.49 in/hr. Influent loading rates range from 1.9 to 35.4 gpm/ft².

The AS-5 field testing results have also been independently verified by NJCAT to achieve 86% TSS removal on an annual basis, consistent with the laboratory findings. The Washington State Department of Ecology subsequently issued Conditional Use Level Designation (CULD) for the Aqua-Swirl® based on the results of the AS-5 field test.

5.0 REGULATORY APPROVALS

The approval lists included herein are not intended to represent all Aqua-Swirl® approvals or installation locations. Instead, the listings represent regulatory agencies that have some recognized measure of technology review in association with their local approval process for manufactured stormwater treatment devices (MTDs). Given that there are a number of scenarios that can be followed in order to gain a regulatory approval, the lists included below provide a high level of credibility toward the approval of the Aqua-Swirl® in a variety of regional and regulatory diverse settings. Additional information can be provided regarding regulatory approvals and installation locales.

Table 2. Summary of Sediment Removal Efficiency and Storm Characteristics

#	Sample Date	TSS RE (%)	SSC RE (%)	Storm Duration (hr:min)	Storm Size (in)	Peak Storm Intensity (in/hr)	Peak Loading Rate (gpm/ft ²)	% TVSS of TSS
1	3/14/2009	98.3	99.3	0:30	0.11	0.26	4.1	NA
2	4/1/2009	86.8	82.7	0:50	0.18	0.46	8.1	NA
3	4/6/2009	82.5	85.5	2:00	0.15	0.26	4.8	NA
4	12/25-26/2009	99.0	99.5	11:45	0.56	0.38	4.8	NA
5	1/17/2010	94.8	96.3	4:48	0.59	0.42	10.4	NA
6	7/25/2010	94.1	96.5	0:46	0.55	1.21	16.9	38.8
7	8/12/2010	63.9	68.0	3:00	1.82	5.49	30.9	22.3
8	9/12/2010	96.5	96.6	3:45	0.61	0.49	13.1	31.0
9	9/29-30/2010	59.9	57.4	12:05	4.40	2.56	35.4	20.9
10	12/1/2010	89.1	86.9	6:20	0.71	1.82	4.1	16.7
11	12/11/2010	96.1	97.7	3:40	0.72	0.58	2.3	29.2
12	2/25/2011	73.0	72.8	2:15	0.29	0.25	4.1	29.0
13	3/6/2011	86.1	92.5	4:50	1.42	0.46	11.0	25.4
14	3/15-16/2011	88.1	91.7	5:06	0.42	0.35	1.9	24.4
15	4/8/2011	94.1	95.8	3:55	0.52	0.15	3.4	25.2
16	4/28/2011	80.4	82.0	2:19	0.23	0.23	12.5	71.4
17	5/14/2011	90.6	90.3	3:05	0.85	0.47	5.7	48.9
18	6/16/2011	74.3	82.7	3:20	1.03	0.91	13.1	48.9
	Average	86.0	87.3		0.84	0.93	10.4	33.2
				Total	15.16			

5.1 States and Provinces

The following states and Ontario are recognized to issue use level designation for MTDs. Both NJDEP and Washington State administer the most widely recognized stormwater management programs throughout the U.S.

State / Province	Agency	Aqua-Swirl® Approval Status
New Jersey	Department of Environmental Protection	Field Test Certification
		Laboratory Test Certification
Washington	Department of Ecology	General Use Level Designation for Pretreatment (TSS)
		Conditional Use Level Designation for Basic (TSS) Treatment
Maryland	Department of the Environment	Approved
Virginia	Department of Environmental Quality	Approved (Total Phosphorus 20%)
Wisconsin	Department of Commerce.	Approved
Ontario	Ministry of the Environment	Certificate of Technology Assessment

5.2 State Departments of Transportation

Several states utilize their respective Departments of Transportation as a regulatory agency to administer the MTD approval process. These approvals can include use level designations specific to highway projects and can extend to most other installation applications for which MTD technologies can be utilized. It should also be kept in mind that a number of local jurisdictions also rely on their state's DOT for MTD approvals. The table below lists state DOTs that have approved the Aqua-Swirl®.

State DOT	Aqua-Swirl® Designation
California	Approved
Michigan	Approved
New Jersey	Approved
North Carolina	Provisional Use
Ohio	Qualified Products List
Rhode Island	Approved
Texas	Approved
Utah	Approved

5.3 Regional Planning Authorities / Water Use Districts

The Aqua-Swirl® maintains several approvals at the regional planning authority or water use district levels such that municipalities within those jurisdictions typically adopt these MTD approvals. Examples of such jurisdictional approvals for which the Aqua-Swirl® are cited below.

Jurisdiction	Example Municipality(s)
Northwest Florida Water Mgmt. District	Tallahassee
Nashville, TN Metro Water Services	Nashville, Brentwood, Franklin
Puerto Rico Electric Power Authority	Island
St. Louis, MO Metro Sewer District	St. Louis and surrounding municipalities, Missouri
Tahoe Regional Planning Agency	Lake Tahoe Basin, Nevada and California

5.4 Counties

Aqua-Swirl® approvals have also been issued through several counties that administer stormwater management programs that include an MTD approval process. These approvals may be implemented such that an MTD can be installed at locations only outside of an incorporated municipality in that county (e.g., Montgomery County). Or, the county approval can be used such that an Aqua-Swirl® can be installed at any location within the county (e.g., Whitfield County). The Aqua-Swirl® is approved at the following county levels:

County	State	Example Municipality(s) w/in County
Ada, Highway District	Idaho	Boise
Hamilton	Tennessee	Chattanooga
Knox	Tennessee	Knoxville
Los Angeles	California	Greater Los Angeles area
Montgomery	Maryland	Unincorporated areas
San Diego	California	San Diego
Whitfield	Georgia	Dalton

5.5 Municipalities

A representative list of municipalities that have required some degree of Aqua-Swirl® evaluation and approval is provided below. It should again be kept in mind that this list does not include every locale where either approvals or installations have occurred.

State / Province	Municipality	State / Province	Municipality
Alabama	Mobile	North Carolina	Hendersonville
California	Santa Monica	Ontario	Hamilton
	Stockton		Oshawa
Georgia	Alpharetta		Ottawa
Hawaii	Honolulu		Simcoe
Idaho	Boise		Toronto (pending)
	Caldwell	Oregon	Eugene
	Meridian	Prineville	
Indiana	Auburn	Quebec	Montréal
	Fishers		Port de Tois-Rivières
	Indianapolis		Quebec City
Maryland	Rockville		Lac Mégantic
	Bethesda	Tennessee	Chattanooga
	Laurel	Knoxville	
	Waldorf	Murfreesboro	
Michigan	Farmington Hills	Utah	Salt Lake City
	Fenton		South Jordan
	Novi		Vernal
Montana	Billings	Washington (Eastern)	Spokane
	Bozeman	Washington D.C.	District of Columbia
	Butte	Wyoming	Jackson Hole

6.0 LIMITED WARRANTY

An Aqua-Swirl® one year limited warranty comes standard with each device and covers against failure due to improper workmanship or defective materials for one year from delivery date. Liability limitations are described in the warranty which is available on request.



Aqua-Swirl[®]

Stormwater Treatment System

Inspection and Maintenance Manual



AquaShield[™], Inc.
2733 Kanasita Drive
Suite 111
Chattanooga, TN 37343
Toll free (888) 344-9044
Phone: (423) 870-8888
Fax: (423) 826-2112
Email: info@aquashieldinc.com
www.aquashieldinc.com

March 2014

Table of Contents

	<u>Page(s)</u>
• AquaShield™ Stormwater Treatment Systems	3
• Aqua-Swirl® Stormwater Treatment System	4 – 9
• Inspection and Maintenance Worksheets and Attachments	10 – 13
• Aqua-Swirl® Tabular Maintenance Schedule	14

AquaShield™, Inc.
2733 Kanasita Drive
Suite 111
Chattanooga, Tennessee 37343
Toll free (888) 344-9044
Fax (423) 870-2112
www.aquashieldinc.com



AquaShield™, Inc

Stormwater Treatment Solutions

The highest priority of AquaShield™, Inc. (AquaShield™) is to protect waterways by providing stormwater treatment solutions to businesses across the world. These solutions have a reliable foundation based on over 20 years of water treatment experience.

Local regulators, engineers, and contractors have praised the AquaShield™ systems for their simple design and ease of installation. All the systems are fabricated from high performance, durable and lightweight materials. Contractors prefer the quick and simple installation of our structures that saves them money.

The patented line of AquaShield™ stormwater treatment products that provide high levels of stormwater treatment include the following:

- **Aqua-Swirl® Stormwater Treatment System:** hydrodynamic separator, which provides a highly effective means for the removal of sediment, floating debris and free-oil.
- **Aqua-Filter™ Stormwater Filtration System:** treatment train stormwater filtration system capable of removing gross contaminants, fine sediments, waterborne hydrocarbons, heavy metals and total phosphorous.



Aqua-Swirl® Stormwater Treatment System



Aqua-Filter™ Stormwater Filtration System



Aqua-Swirl[®] Stormwater Treatment System

The patented Aqua-Swirl[®] Stormwater Treatment System is a single chamber hydrodynamic separator which provides a highly effective means for the removal of sediment, free oil, and floating debris. Both treatment and storage are accomplished in the swirl chamber without the use of multiple or “blind” chambers. Independent laboratory and field performance verifications have shown that the Aqua-Swirl[®] achieves over 80% suspended solids removal efficiency on a net annual basis.

The Aqua-Swirl[®] is most commonly installed in an “off-line” configuration. Or, depending on local regulations, an “in-line” (on-line) conveyance flow diversion (CFD) system can be used. The CFD model allows simple installation by connecting directly to the existing storm conveyance pipe thereby providing full treatment of the “first flush,” while the peak design storm is diverted and channeled through the main conveyance pipe.

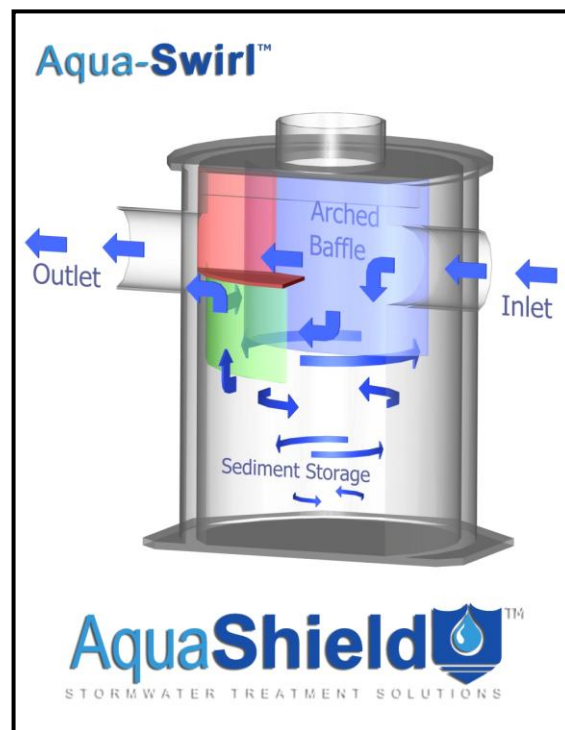

The patented Aqua-Swirl[®] Stormwater Treatment System provides a highly effective means for the removal of sediment, floating debris, and free oil. Swirl technology, or vortex separation, is a proven form of treatment utilized in the stormwater industry to accelerate gravitational separation.



Floatable debris in the Aqua-Swirl®

Each Aqua-Swirl® is constructed of high performance, lightweight and durable materials including polymer coated steel (PCS), high density polyethylene (HDPE), or fiberglass reinforced polymer (FRP). These materials eliminate the need for heavy lifting equipment during installation.



System Operation

The treatment operation begins when stormwater enters the Aqua-Swirl® through a tangential inlet pipe that produces a circular (or vortex) flow pattern that causes contaminants to settle to the base of the unit. Since stormwater flow is intermittent by nature, the Aqua-Swirl® retains water between storm events providing both dynamic and quiescent settling of solids. The dynamic settling occurs during each storm event while the quiescent settling takes place between successive storms. A combination of gravitational and hydrodynamic drag forces encourages the solids to drop out of the flow and migrate to the center of the chamber where velocities are the lowest.

The treated flow then exits the Aqua-Swirl® behind the arched outer baffle. The top of the baffle is sealed across the treatment channel, thereby eliminating floatable pollutants from escaping the system. A vent pipe is extended up the riser to expose the backside of the baffle to atmospheric conditions, preventing a siphon from forming at the bottom of the baffle.



Custom Applications

The Aqua-Swirl® system can be modified to fit a variety of purposes in the field, and the angles for inlet and outlet lines can be modified to fit most applications. The photo below demonstrates the flexibility of Aqua-Swirl® installations using a “twin” configuration in order to double the

water quality treatment capacity. Two Aqua-Swirl[®] units were placed side by side in order to treat a high volume of water while occupying a small amount of space.



Custom designed AS-9 Twin Aqua-Swirl[®]



Retrofit Applications

The Aqua-Swirl[®] system is designed so that it can easily be used for retrofit applications. With the invert of the inlet and outlet pipe at the same elevation, the Aqua-Swirl[®] can easily be connected directly to the existing storm conveyance drainage system. Furthermore, because of the lightweight nature and small footprint of the Aqua-Swirl[®], existing infrastructure utilities (i.e., wires, poles, trees) would be unaffected by installation.



AquaShield[™] Product System Maintenance

The long term performance of any stormwater treatment structure, including manufactured or land based systems, depends on a consistent maintenance plan. Inspection and maintenance functions are simple and easy for the AquaShield[™] Stormwater Treatment Systems allowing all inspections to be performed from the surface.

It is important that a routine inspection and maintenance program be established for each unit based on: (a) the volume or load of the contaminants of concern, (b) the frequency of releases of contaminants at the facility or location, and (c) the nature of the area being drained.

In order to ensure that our systems are being maintained properly, AquaShield[™] offers a maintenance solution to all of our customers. We will arrange to have maintenance performed.



Inspection

All AquaShield™ products can be inspected from the surface, eliminating the need to enter the systems to determine when cleanout should be performed. In most cases, AquaShield™ recommends a quarterly inspection for the first year of operation to develop an appropriate schedule of maintenance. Based on experience of the system's first year in operation, we recommend that the inspection schedule be revised to reflect the site-specific conditions encountered. Typically, the inspection schedule for subsequent years is reduced to semi-annual inspection.



Aqua-Swirl® Maintenance

The Aqua-Swirl® has been designed to minimize and simplify the inspection and maintenance process. The single chamber system can be inspected and maintained entirely from the surface thereby eliminating the need for confined space entry. Furthermore, the entire structure (specifically, the floor) is accessible for visual inspection from the surface. There are no areas of the structure that are blocked from visual inspection or periodic cleaning. Inspection of any free-floating oil and floatable debris can be directly observed and maintained through the manhole access provided directly over the swirl chamber.

Aqua-Swirl® Inspection Procedure

To inspect the Aqua-Swirl®, a hook is needed to remove the manhole cover. AquaShield™ provides a customized manhole cover with our distinctive logo to make it easy for maintenance crews to locate the system in the field. We also provide a permanent metal information plate

affixed inside the access riser which provides our contact information, the Aqua-Swirl[®] model size, and serial number.

The only tools needed to inspect the Aqua-Swirl[®] system are a flashlight and a measuring device such as a stadia rod or pole. Given the easy and direct accessibility provided, floating oil and debris can be observed directly from the surface. Sediment depths can easily be determined by lowering a measuring device to the top of the sediment pile and to the surface of the water.



Sediment inspection using a stadia rod in a single chamber

The maintenance trigger for Aqua-Swirl[®] Models AS-3 through AS-13 occurs when the sediment pile is within 42 to 48 inches of the standing water surface. For the Aqua-Swirl[®] Model AS-2, maintenance is needed when the top of the sediment pile is measured to be 30 to 32 inches below the standing water surface.

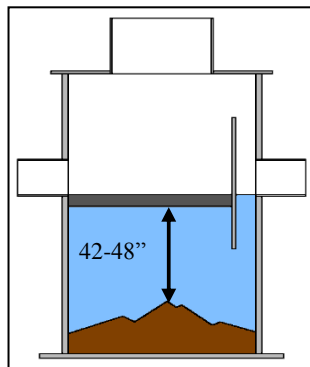

Maintenance trigger for Aqua-Swirl[®] Models AS-3 through AS-13 occurs when sediment pile is 42-48 inches below water surface.

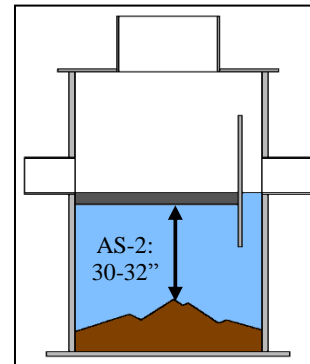

Maintenance trigger for Aqua-Swirl[®] Model AS-2 occurs when sediment pile is 30 to 32 inches below water surface.

It should be noted that in order to avoid underestimating the volume of sediment in the chamber, the measuring device must be carefully lowered to the *top* of the sediment pile. Keep in mind that the finer sediment at the top of the pile may offer less resistance to the measuring device than the larger particles which typically occur deeper within the sediment pile.

The Aqua-Swirl[®] design allows for the sediment to accumulate in a semi-conical fashion as illustrated above. That is, the depth to sediment as measured below the water surface may be less in the center of the swirl chamber; and likewise, may be greater at the edges of the swirl chamber.

Aqua-Swirl[®] Cleanout Procedure

Cleaning the Aqua-Swirl[®] is simple and quick. Free-floating oil and floatable debris can be observed and removed directly through the 30-inch service access riser provided. A vacuum truck is typically used to remove the accumulated sediment and debris. An advantage of the Aqua-Swirl[®] design is that the entire sediment storage area can be reached with a vacuum hose from the surface (reaching all the sides). Since there are no multiple or limited (hidden or “blind”) chambers in the Aqua-Swirl[®], there are no restrictions to impede on-site maintenance tasks.

Disposal of Recovered Materials

Disposal of recovered material is typically handled in the same fashion as catch basin cleanouts. AquaShield[™] recommends that all maintenance activities be performed in accordance with appropriate health and safety practices for the tasks and equipment being used.

AquaShield[™] also recommends that all materials removed from the Aqua-Swirl[®] and any external structures (e.g, bypass features) be handled and disposed in full accordance with any applicable local and state requirements.



Vacuum truck quickly cleans the Aqua-Swirl[®] from a single chamber

***Aqua-Swirl[®] Inspection and Maintenance Work Sheets
on following pages***

Aqua-Swirl[®] Inspection and Maintenance Manual

Work Sheets

SITE and OWNER INFORMATION

Site Name: _____

Site Location: _____

Date: _____ Time: _____

Inspector Name: _____

Inspector Company: _____ Phone #: _____

Owner Name: _____

Owner Address: _____

Owner Phone #: _____ Emergency Phone #: _____

INSPECTIONS

I. Floatable Debris and Oil

1. Remove manhole lid to expose liquid surface of the Aqua-Swirl[®].
2. Remove floatable debris with basket or net if any present.
3. If oil is present, measure its depth. Clean liquids from system if one half (1/2) inch or more oil is present.

Note: Water in Aqua-Swirl[®] can appear black and similar to oil due to the dark body of the surrounding structure. Oil may appear darker than water in the system and is usually accompanied by oil stained debris (e.g. Styrofoam, etc.). The depth of oil can be measured with an oil/water interface probe, a stadia rod with water finding paste, a coliwasa, or collect a representative sample with a jar attached to a rod.

II. Sediment Accumulation

1. Lower measuring device (e.g. stadia rod) into swirl chamber through service access provided until top of sediment pile is reached.
2. Record distance to top of sediment pile from top of standing water: _____ inches
3. For Aqua-Swirl[®] Models AS-3 through AS-13, schedule cleaning if value in Step #2 is 48 to 42 inches or less.
4. For Aqua-Swirl[®] Model AS-2, schedule cleaning if value in Step #2 is 32 to 30 inches or less.

III. Diversion Structures (External Bypass Features)

If a diversion (external bypass) configuration is present, it should be inspected as follows:

1. Inspect weir or other bypass feature for structural decay or damage. Weirs are more susceptible to damage than off-set piping and should be checked to confirm that they are not crumbling (concrete or brick) or decaying (steel).
2. Inspect diversion structure and bypass piping for signs of structural damage or blockage from debris or sediment accumulation.
3. When feasible, measure elevations on diversion weir or piping to ensure it is consistent with site plan designs.
4. Inspect downstream (convergence) structure(s) for sign of blockage or structural failure as noted above.

CLEANING

Schedule cleaning with local vacor company or AquaShield™ to remove sediment, oil and other floatable pollutants. The captured material generally does not require special treatment or handling for disposal. Site-specific conditions or the presence of known contaminants may necessitate that appropriate actions be taken to clean and dispose of materials captured and retained by the Aqua-Swirl®. All cleaning activities should be performed in accordance with property health and safety procedures.

AquaShield™ always recommends that all materials removed from the Aqua-Swirl® during the maintenance process be handled and disposed in accordance with local and state environmental or other regulatory requirements.

MAINTENANCE SCHEDULE

I. During Construction

Inspect the Aqua-Swirl® every three (3) months and clean the system as needed. The Aqua-Swirl® should be inspected and cleaned at the end of construction regardless of whether it has reached its maintenance trigger.

II. First Year Post-Construction

Inspect the Aqua-Swirl® every three (3) months and clean the system as needed.

Inspect and clean the system once annually regardless of whether it has reached its sediment or floatable pollutant storage capacity.

III. Second and Subsequent Years Post-Construction

If the Aqua-Swirl® did not reach full sediment or floatable pollutant capacity in the First Year Post-Construction period, the system can be inspected and cleaned once annually.

If the Aqua-Swirl® reached full sediment or floatable pollutant capacity in less than 12 months in the First Year Post-Construction period, the system should be inspected once

every six (6) months and cleaned as needed. The Aqua-Swirl[®] should be cleaned annually regardless of whether it reaches its sediment or floatable pollutant capacity.

IV. Bypass Structures

Bypass structures should be inspected whenever the Aqua-Swirl[®] is inspected. Maintenance should be performed on bypass structures as needed.

MAINTENANCE COMPANY INFORMATION

Company Name: _____

Street Address: _____

City: _____ State/Prov.: _____ Zip/Postal Code: _____

Contact: _____ Title: _____

Office Phone: _____ Cell Phone: _____

ACTIVITY LOG

Date of Cleaning: _____ (Next inspection should be 3 months from this data for first year).

Time of Cleaning: Start: _____ End: _____

Date of Next Inspection: _____

Floatable debris present: Yes No

Notes: _____

Oil present: Yes No Oil depth (inches): _____

Measurement method and notes: _____

STRUCTURAL CONDITIONS and OBSERVATIONS

Structural damage: Yes No Where: _____

Structural wear: Yes No Where: _____

Odors present: Yes No Describe: _____

Clogging: Yes No Describe: _____

Other Observations: _____

NOTES

Additional Comments and/or Actions To Be Taken	Time Frame

ATTACHMENTS

- Attach site plan showing Aqua-Swirl® location.
- Attach detail drawing showing Aqua-Swirl® dimensions and model number.
- If a diversion configuration is used, attach details showing basic design and elevations (where feasible).

Aqua-Swirl®

TABULAR MAINTENANCE SCHEDULE

Date Construction Started: _____

Date Construction Ended: _____

During Construction

Activity	Month											
	1	2	3	4	5	6	7	8	9	10	11	12
Inspect and Clean as needed			X			X			X			X
Inspect Bypass and maintain as needed			X			X			X			X
Clean System*												X*

* The Aqua-Swirl® should be cleaned **once a year** regardless of whether it has reached full pollutant storage capacity. In addition, the system should be cleaned at the **end of construction** regardless of whether it has reach full pollutant storage capacity.

First Year Post-Construction

Activity	Month											
	1	2	3	4	5	6	7	8	9	10	11	12
Inspect and Clean as needed			X			X			X			X
Inspect Bypass and maintain as needed			X			X			X			X
Clean System*												X*

* The Aqua-Swirl® should be cleaned **once a year** regardless of whether it has reached full pollutant storage capacity.

Second and Subsequent Years Post-Construction

Activity	Month											
	1	2	3	4	5	6	7	8	9	10	11	12
Inspect and Clean as needed												X*
Inspect Bypass, maintain as needed												X*
Clean System*												X*

* If the Aqua-Swirl® did **not** reach full sediment or floatable pollutant capacity in the First Year Post-Construction period, the system can be inspected and cleaned once annually.

If the Aqua-Swirl® **reached** full sediment or floatable pollutant capacity in less than 12 months in the First Year Post-Construction period, the system should be inspected once every six (6) months or more frequently if past history warrants, and cleaned as needed. The Aqua-Swirl® should be cleaned annually regardless of whether it reaches its full sediment or floatable pollutant capacity.

Appendix 4.3 Corrugated Metal Pipe (CMP) Information



URBANGREEN™



Metal Detention and Infiltration Products

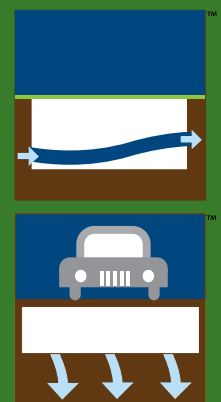
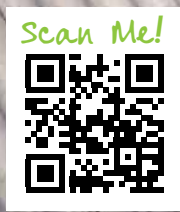

CONTECH
ENGINEERED SOLUTIONS

Corrugated Metal Pipe for Stormwater Detention and Infiltration

Selecting the right stormwater solution just got easier...

It's simple to choose the right low impact development (LID) solution to achieve your runoff reduction goals with the Contech UrbanGreen™ Staircase. First, select the runoff reduction practices that are most appropriate for your site, paying particular attention to pretreatment needs. If the entire design storm cannot be retained, select a treatment best management practice (BMP) for the balance. Finally, select a detention system to address any outstanding downstream erosion.

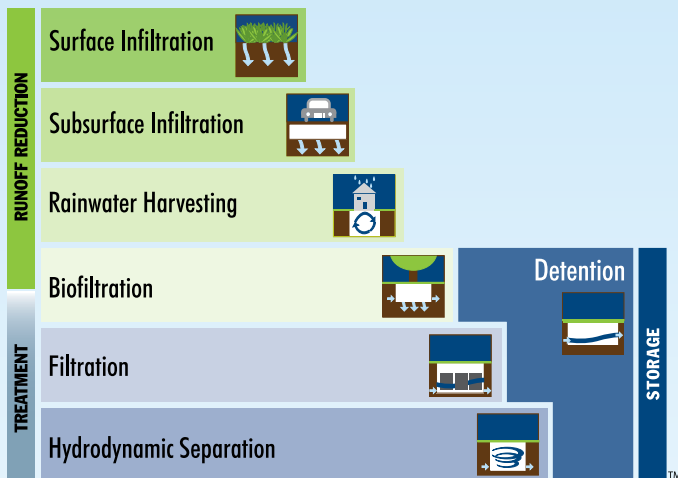

Learn more about our low impact development at:
www.ContechES.com/lid

Meet your stormwater quantity and runoff reduction requirements with ease.

Contech's corrugated metal pipe (CMP) underground detention/infiltration systems can be sized and shaped to meet your site-specific needs. The versatile material provides almost limitless opportunities to match individual site requirements while lowering site development costs.

Durable

- Proven service life – Exceeds 100-years with proper specification that meets all AASHTO and ASTM pipe specifications
- Handles fill heights in excess of 100 feet – steel combines strength with soil
- 100% traceable material – maintains performance even when recycled
- Homogenous material – eliminates failures due to stress cracks, shrinkage cracks and air voids
- Various coatings available with predictable service life
 - Aluminized Steel™ Type 2
 - Galvanized
 - CORLIX®
 - TRENCHCOAT®

Learn more about our available coatings at:
www.ContechES.com/cmp



Various coatings available

Versatile

- Wide range of shapes and sizes – round and pipe-arch in diameters from 6 to 144 inches
- Variety of layouts – rectangular, L-shape and staggered cells are frequently used
- Array of fittings – tees, wyes, elbow, saddle branches, manifolds, reducers and custom fabrication available

Sustainable

- World's most recycled content – can count towards LEED® credits
- Requires less energy and materials to produce – lowers carbon footprint



Learn how Contech products can help contribute to LEED credits at:
www.ContechES.com/LEED

Easy to Install and Maintain

- Flexible and forgiving during installation
- Lightweight for easy handling
- Quick assembly shortens site development time
- Integrated outlet control structure eliminates need for downstream control structure
- Manhole riser sections, complete with ladders facilitate any access and scheduled maintenance



Tees, wyes, elbows, saddle branches, manifolds and reducers are available

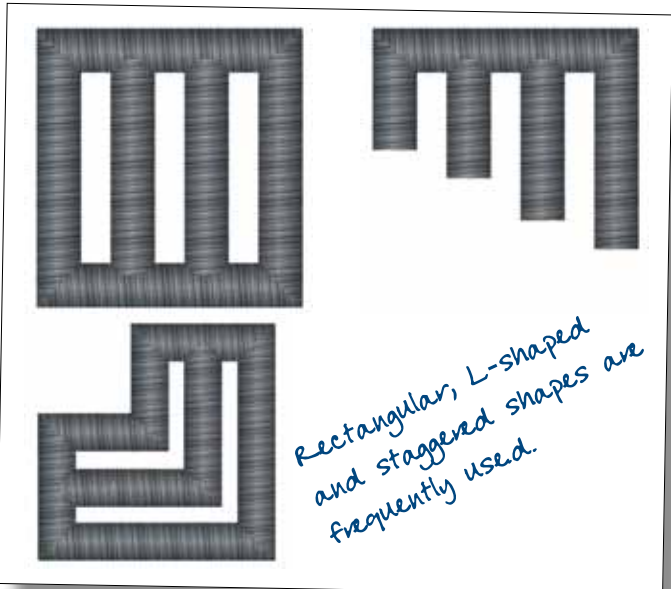

Typical Spacing for Multiple Barrels



Diameter	Spacing*	Pipe-Arch Span	Spacing*
Up to 24"	12"	Up to 36"	12"
24" to 72"	1/2 Diameter of Pipe	36" to 108"	1/3 Span of Pipe-Arch
72" +	36"	108" to 189"	36"

* Spacing shown provides room for proper backfill to enable the structure to develop adequate side support. Spacing with AASHTO M-145, A-1, A-2, A-3 granular fill. Closer spacing is possible depending on quality of backfill and placing and compaction methods.

Applications

Detention

Contech CMP detention systems store stormwater runoff exceeding a site's allowable discharge rate and release it slowly over time. Installed belowgrade, the systems maximize property usage and meet your specific water quantity requirements. CMP detention systems are available in all AASHTO M-36 Types. For larger systems, the Optimizer™ flow control device can reduce required storage volume.

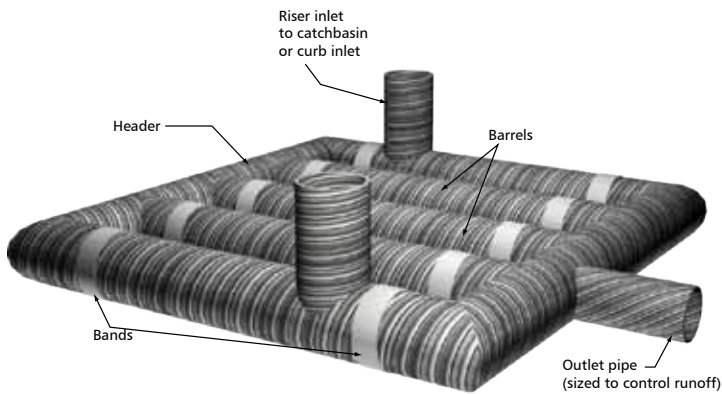

CMP detention system

High Volume Storage

Contech plate systems allow for high volume stormwater storage in small footprint areas. The systems are offered in a wide variety of shapes and sizes in both aluminum and galvanized steel. Full-pipe systems and three-sided structures with open bottoms can be used for infiltration.

Typically, Contech plate systems are used on high vertical rise applications or in areas where the smallest possible footprint is of the greatest concern. The systems are bolted together in the field, which reduces the number of freight loads. Remote sites or projects with challenging accessibility often utilize plate systems.



Plate system for high volume storage



Perforated CMP infiltration system

Infiltration

CMP pipe and pipe-arch is available fully or partially perforated to meet your Low Impact Development (LID) requirements. Standard pipe-wall perforations (3/8" diameter holes meeting AASHTO M-36, Class 2) provide approximately 2.5% open area. Subsurface perforated CMP infiltration systems store stormwater runoff in the pipe and surrounding stone during a storm until it can be slowly released into the surrounding native soil.



Stormwater runoff is stored in the pipe and surrounding stone



Meet Your Low Impact
Development Requirements



Pipe-arch for low profile application.

Low Profile

When vertical space must be maximized, the CMP can be utilized in a pipe-arch shape. The low, wide pipe-arch design allows for greater storage in a shallow profile than typical round pipe without losing any structural integrity. Like our round pipe, pipe arch is produced in six wall thicknesses including 18, 16, 14, 12, 10 and 8 gage, which are available with either helical or annular corrugations.

Applications

On-Site Manufacturing

If your job site is remote or you have limited storage space or restricted traffic patterns, take advantage of our Mobile Production Vehicle (MPV) for fast and cost effective on-site steel pipe manufacturing. The PIPE MPV® is designed to be a self-supporting factory that can be quickly deployed and put into production. Once on site, pipe manufacturing progresses quickly enough to allow pipe installation within four hours.

The PIPE MPV can produce corrugated metal pipe in a variety of sizes. Diameters from 36" – 192" and lengths up to 35' can be accommodated. This pipe meets the same levels of quality construction as does all Contech manufactured pipe, with high coil feedrate speeds and the same lock-seam edge process used in conventional pipe manufacturing.

Innovative Solutions for Challenging Sites

The flexibility of CMP allows you to create innovative solutions when dealing with challenging sites. For example, when trying to meet runoff reduction requirements, your site may be mostly impervious or you may have a thin, shallow clay layer just below the surface, limiting the infiltration capacity of surface BMPs. One solution is to utilize CMP infiltration wells. First, collect the site runoff using our Slotted Drain™ around the perimeter of each drive aisle. The Slotted Drain then directs water into vertical lengths of perforated CMP. The vertical perforated CMP is long enough to penetrate the clay layer and infiltrate the stormwater into a highly permeable alluvial layer about 12'-14' belowground. This allows the developer to meet the LID requirements and eliminate the need for the extended detention basin.



Mobile Production vehicle

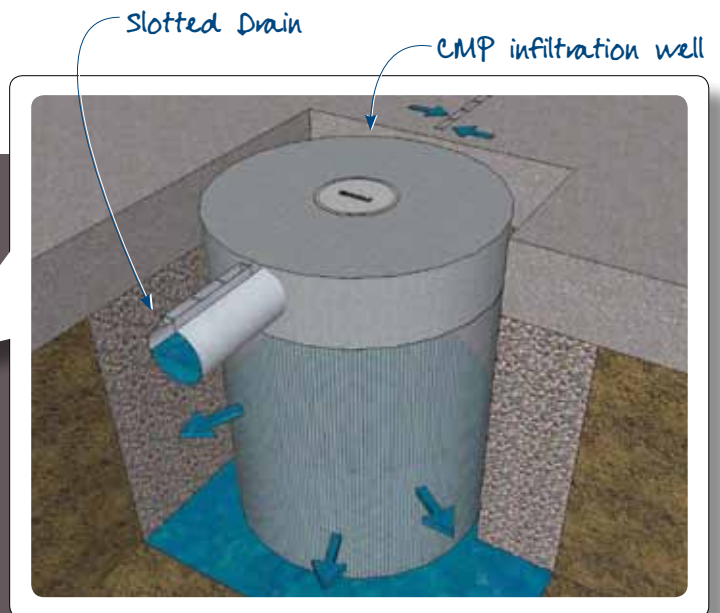
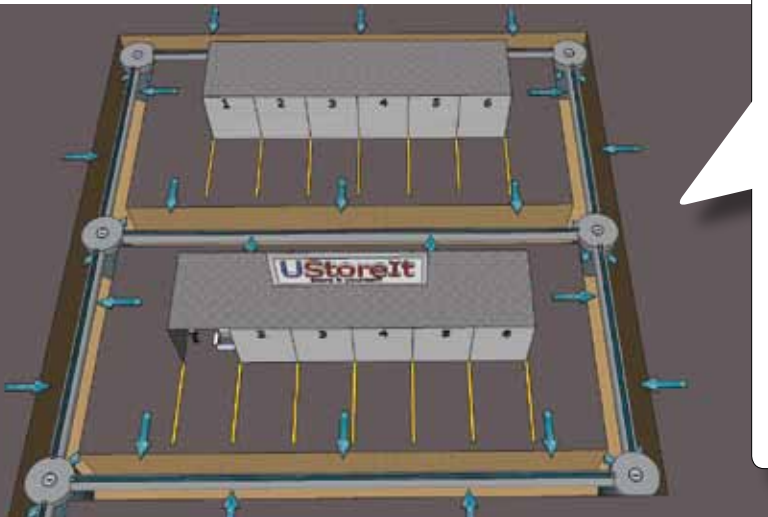

Sizing

Round Pipe - CMP and Plate (CMP → 12-in to 144-in; Plate → 60-in to 240-in)

Diameter (inches)	Volume (ft ³ /ft)	Min. Cover Height	Diameter (inches)	Volume (ft ³ /ft)	Min. Cover Height	Diameter (inches)	Volume (ft ³ /ft)	Min. Cover Height	Diameter (inches)	Volume (ft ³ /ft)	Min. Cover Height
12	.78	12"	60	19.6	12"	120	78.5	18"	180	176	24"
15	1.22	12"	66	23.7	12"	126	86.5	18"	186	188	24"
18	1.76	12"	72	28.2	12"	132	95.0	18"	192	201	24"
21	2.40	12"	78	33.1	12"	138	103.8	18"	198	213	30"
24	3.14	12"	84	38.4	12"	144	113.1	18"	204	227	30"
30	4.9	12"	90	44.1	12"	150	122	24"	210	240	30"
36	7.0	12"	96	50.2	12"	156	132	24"	216	254	30"
42	9.6	12"	102	56.7	18"	162	143	24"	222	268	30"
48	12.5	12"	108	63.6	18"	168	153	24"	228	283	30"
54	15.9	12"	114	70.8	18"	174	165	24"	234	298	30"

Pipe-Arch - CMP

1/2" Deep Corrugations											
Shape (inches)	Volume (ft ³ /ft)	Min. Cover Height	Shape (inches)	Volume (ft ³ /ft)	Min. Cover Height	Shape (inches)	Volume (ft ³ /ft)	Min. Cover Height	Shape (inches)	Volume (ft ³ /ft)	Min. Cover Height
17 x 13	1.1	12"	28 x 20	2.9	12"	49 x 33	8.9	12"	71 x 47	18.1	12"
21 x 15	1.6	12"	35 x 24	4.5	12"	57 x 38	11.6	12"	77 x 52	21.9	12"
24 x 18	2.2	12"	42 x 29	6.5	12"	64 x 43	14.7	12"	83 x 57	26.0	12"
1" Deep Corrugations											
60 x 46	15.6	15"	81 x 59	27.4	18"	103 x 71	42.4	18"	128 x 83	60.5	24"
66 x 51	19.3	15"	87 x 63	32.1	18"	112 x 75	48.0	21"	137 x 87	67.4	24"
73 x 55	23.2	18"	95 x 67	37.0	18"	117 x 79	54.2	21"	142 x 91	74.5	24"

Pipe-Arch - MULTI-PLATE®

2" Deep Corrugations												
	Shape (ft-in)	Volume (ft ³ /ft)	Min. Cover Height	Shape (inches)	Volume (ft ³ /ft)	Min. Cover Height	Shape (inches)	Volume (ft ³ /ft)	Min. Cover Height	Shape (inches)	Volume (ft ³ /ft)	Min. Cover Height
18-in Corner Radius (Rc)	6-1 x 4-7	22	12"	8-7 x 5-11	41	18"	8-7 x 5-11	41	18"	14-1 x 8-9	97	24"
	6-4 x 4-9	24	12"	8-10 x 6-1	43	18"	8-10 x 6-1	43	18"	14-3 x 8-11	101	24"
	6-9 x 4-11	26	12"	9-4 x 6-3	46	18"	9-4 x 6-3	46	18"	14-10 x 9-1	105	24"
	7-0 x 5-1	29	12"	9-6 x 6-5	49	18"	9-6 x 6-5	49	18"	15-4 x 9-3	109	24"
	7-3 x 5-3	31	12"	9-9 x 6-7	52	18"	9-9 x 6-7	52	18"	15-6 x 9-5	114	24"
	7-8 x 5-5	33	12"	10-3 x 6-9	55	18"	10-3 x 6-9	55	18"	15-8 x 9-7	118	24"
	7-11 x 5-7	36	12"	10-8 x 6-11	58	18"	10-8 x 6-11	58	18"	15-10 x 9-10	122	24"
	8-2 x 5-9	38	18"	10-11 x 7-1	61	18"	10-11 x 7-1	61	18"	16-5 x 9-11	126	30"
31-in Corner Radius (Rc)	13-3 x 9-4	98	24"	15-4 x 10-4	124	24"	17-2 x 11-4	153	30"	19-3 x 12-4	185	30"
	13-6 x 9-6	102	24"	15-7 x 10-6	129	24"	17-5 x 11-6	158	30"	19-6 x 12-6	191	30"
	14-0 x 9-8	106	24"	15-10 x 10-8	134	24"	17-11 x 11-8	163	30"	19-8 x 12-8	196	30"
	14-2 x 9-10	111	24"	16-3 x 10-10	138	30"	18-1 x 11-10	168	30"	19-11 x 12-10	202	30"
	14-5 x 10-0	115	24"	16-6 x 11-0	143	30"	18-7 x 12-0	174	30"	20-5 x 13-0	208	30"
	14-11 x 10-2	120	24"	17-0 x 11-2	148	30"	18-9 x 12-2	179	30"	20-7 x 13-2	214	36"



Next Steps

Learn more

Read our white paper, *Economic Optimization of Infiltration Systems*, to learn more. You'll receive free PDH credits for completing a quick quiz.

Available at www.ContechES.com/cmp

Quick Links:

- LEED information – www.ContechES.com/leed
- LID Application Guide – www.ContechES.com/lid
- Articles – www.ContechES.com/pdh

Connect with us

We're here to make your job easier – and that includes being able to get in touch with us when you need to. Search for your local rep at www.ContechES.com

While you're there, be sure to check out our upcoming seminar schedule or request an in-house technical presentation.

Links to Stormwater Tools:

To use the Design Your Own Detention System tool, visit: www.ContechES.com/dyods

To use the Land Value Calculator, visit: www.ContechES.com/lvc

(Please scroll to the bottom right to download the Land Value Calculator)

To use the Rain Water Harvesting Runoff Reduction Calculator tool, visit: www.ContechES.com/rwh-calculator

Start a Project

If you are ready to begin a project, contact your local representative to get started. Or you can check out our design toolbox for all our online resources at www.ContechES.com/designtoolbox.



©2012 Contech Engineered Solutions LLC
800.338.1122
www.ContechES.com
All Rights Reserved. Printed in the USA.

NOTHING IN THIS CATALOG SHOULD BE CONSTRUED AS AN EXPRESSED WARRANTY OR AN IMPLIED WARRANTY OF MERCHANTABILITY OR FITNESS FOR ANY PARTICULAR PURPOSE. SEE THE CONTECH STANDARD CONDITIONS OF SALE (VIEWABLE AT WWW.CONTECHES.COM/COS) FOR MORE INFORMATION.

Get Social With Us!



Scan Me!

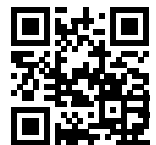

We print our brochures entirely on Forest Stewardship Council certified paper. FSC certification ensures that the paper in our brochures contain fiber from well-managed and responsibly harvested forests that meet strict environmental and socioeconomic standards.

FSC



Maintenance

Underground storm water detention and retention systems should be inspected at regular intervals and maintained when necessary to ensure optimum performance. The rate at which the system collects pollutants will depend more heavily on site activities than the size or configuration of the system.

Inspection

Inspection is the key to effective maintenance and is easily performed. CONTECH recommends ongoing quarterly inspections of the accumulated sediment. Sediment deposition and transport may vary from year to year and quarterly inspections will help insure that systems are cleaned out at the appropriate time. Inspections should be performed more often in the winter months in climates where sanding operations may lead to rapid accumulations, or in equipment washdown areas. It is very useful to keep a record of each inspection. A sample inspection log is included for your use.

Systems should be cleaned when inspection reveals that accumulated sediment or trash is clogging the discharge orifice. CONTECH suggests that all systems be designed with an access/inspection manhole situated at or near the inlet and the outlet orifice. Should it be necessary to get inside the system to perform maintenance activities, all appropriate precautions regarding confined space entry and OSHA regulations should be followed.

Cleaning

Maintaining an underground detention or retention system is easiest when there is no flow entering the system. For this reason, it is a good idea to schedule the cleanout during dry weather.

Accumulated sediment and trash can typically be evacuated through the manhole over the outlet orifice. If maintenance is not performed as recommended, sediment and trash may accumulate in front of the outlet orifice. Manhole covers should be securely seated following cleaning activities.

Appendix 5 Calculations

Peak Flow Hydrologic Analysis

File location: C:/Users/Josh/KHR Associates Dropbox/R Drive/Sanka Properties/Documents/LID/Calcs/23.01.20/Butterfly Gardens - Total Site
Version: HydroCalc 1.0.3

Input Parameters

Project Name	Butterfly Gardens
Subarea ID	Total Site
Area (ac)	0.88
Flow Path Length (ft)	200.0
Flow Path Slope (vft/hft)	0.01
85th Percentile Rainfall Depth (in)	1.0
Percent Impervious	0.99
Soil Type	15
Design Storm Frequency	85th percentile storm
Fire Factor	0
LID	True

Output Results

Modeled (85th percentile storm) Rainfall Depth (in)	1.0
Peak Intensity (in/hr)	0.3808
Undeveloped Runoff Coefficient (Cu)	0.1
Developed Runoff Coefficient (Cd)	0.892
Time of Concentration (min)	13.0
Clear Peak Flow Rate (cfs)	0.2989
Burned Peak Flow Rate (cfs)	0.2989
24-Hr Clear Runoff Volume (ac-ft)	0.0649
24-Hr Clear Runoff Volume (cu-ft)	2825.862

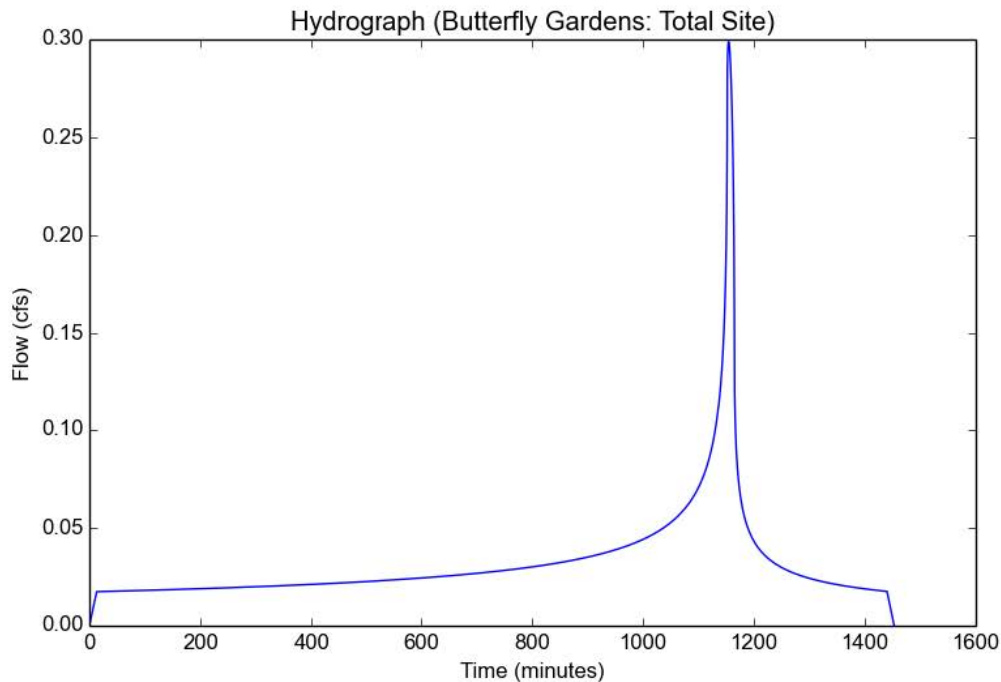

DRYWELL & DETENTION DESIGN CALCULATIONS

Drywell #1

Mitigation Volume, V_{BMP} :	2,826 C.F.	From HydroCalc
Infiltration Rate, $K_{sat,measured}$:	10.62 in/hr	Test Well B2 @ 30 feet
Factor of Safety, FS:	3	
Number of Drywells; $DW_{quantity}$:	1 each	
DW Chamber ϕ :	4 feet	
DW Chamber Area, DWC_{Area} :	12.57 square feet per foot	
DW Chamber Volume, DWC_{Volume} :	12.57 cubic feet per foot	
$DW_{chamber,depth}$:	5 linear feet	
DW Rock Shaft ϕ :	4 feet	
DW Rock Shaft Area, DWR_{Area} :	12.57 square feet per foot	
DW Rock Shaft Volume, DWR_{Volume} :	12.57 cubic feet per foot	
$DW_{rock,depth}$:	20 linear feet	
$DW_{infiltration,depth}$:	24 linear feet	
DW Bottom Area, DWB_{Area} :	12.57 square feet per foot	
T (Maximum Drawdown Time):	96 hr	
CMP Diameter (detention):	6 feet	
CMP_{Volume} :	28.2 cubic feet per foot	
CMP_{Length} :	95 linear feet	

Determine Design Infiltration Rate; $K_{sat,design}$

$$K_{sat,design} = K_{sat,measured} \div FS$$

$$K_{sat,design} = 3.54 \text{ in/hr} \quad 0.295 \text{ ft/hr}$$

Determine Minimum Infiltration Surface Area, A_{min}

$$A_{min} = (V_{BMP} \times 12 \text{ in/ft}) \div (T \times K_{sat,design})$$

$$A_{min} = 100 \text{ S.F.}$$

Determine Infiltration Surface Area, A_{actual}

$$A_{actual} = (DW_{infiltration,depth} \times DWR_{Area} + DWB_{Area}) \times DW_{quantity}$$

$$A_{actual} = 314 \text{ S.F.}$$

Determine Volume of Drywell, $V_{drywell}$

$$V_{drywell} = (DWC_{Volume} \times DW_{chamber,depth}) + (DWR_{Volume} \times DW_{rock,depth} \times 0.40) \times DW_{quantity}$$

$$V_{drywell} = 163 \text{ C.F.}$$

Determine Volume Remaining to Detain in CMP, V_{detain}

$$V_{detain} = V_{BMP} - V_{drywell}$$

$$V_{detain} = 2,663 \text{ C.F.}$$

Determine CMP Detention Volume, $V_{\text{CMP,detain}}$

$$V_{\text{CMP,detain}} = \text{CMP}_{\text{Volume}} \times \text{CMP}_{\text{Length}}$$

$$V_{\text{CMP,detain}} = 2,691 \text{ C.F.}$$

Determine DW & CMP Volume, V_{design}

$$V_{\text{design}} = V_{\text{CMP,detain}} + V_{\text{drywell}}$$

$$V_{\text{design}} = 2,854 \text{ C.F.}$$

Determine Drawdown Time, T_{actual}

$$T_{\text{actual}} = (V_{\text{design}} \times 12 \text{ in/ft}) \div (A_{\text{actual}} \times K_{\text{sat,design}})$$

$$T_{\text{actual}} = 30.79 \text{ hr}$$

Determine Drywell 96 Hour Drawdown Volume, V_{96}

$$V_{96} = T \times (A_{\text{actual}} \times K_{\text{sat,design}} \text{ ft/hr})$$

$$V_{96} = 8,900 \text{ C.F.}$$

Appendix 6 Operations & Maintenance Documents

To Be Provided With Final LID Report

Appendix 7 Geotechnical Investigation

GEOTECHNICAL INVESTIGATION

**PROPOSED MULTI-FAMILY
RESIDENTIAL DEVELOPMENT
910 SOUTH MARIPOSA STREET
BURBANK, CALIFORNIA
APN: 2443-004-017**



GEOCON
WEST, INC.

GEOTECHNICAL
ENVIRONMENTAL
MATERIALS

PREPARED FOR

**BUTTERFLY GARDENS, LLC
LOS ANGELES, CALIFORNIA**

PROJECT NO. W1696-06-01

JANUARY 10, 2023



Project No. W1696-06-01
January 10, 2023

VIA EMAIL

Mr. Garen Gozumian
Butterfly Gardens, LLC
625 S. Hill Street Suite 249
Los Angeles, CA 90014

Subject: GEOTECHNICAL INVESTIGATION
PROPOSED 3-STORY MULTI-FAMILY RESIDENTIAL DEVELOPMENT
910 SOUTH MARIPOSA STREET
BURBANK, CALIFORNIA
APN: 2443-004-017

Dear Mr. Gozumian:

In accordance with your authorization of our proposal dated November 10, 2022, we have performed a geotechnical investigation for the proposed multi-family residential development located at 910 South Mariposa Street in the City of Burbank, California. The accompanying report presents the findings of our study and our conclusions and recommendations pertaining to the geotechnical aspects of proposed design and construction. Based on the results of our investigation, it is our opinion that the site can be developed as proposed, provided the recommendations of this report are followed and implemented during design and construction.

If you have any questions regarding this report, or if we may be of further service, please contact the undersigned.

Very truly yours,

GEOCON WEST, INC.

Joshua Kulas
Staff Engineer

(EMAIL) Addressee



Harry Derkalousdian
PE 79694



Susan F. Kirkgard
CEG 1754

TABLE OF CONTENTS

1.	PURPOSE AND SCOPE	1
2.	SITE AND PROJECT DESCRIPTION	1
3.	GEOLOGIC SETTING.....	2
4.	SOIL AND GEOLOGIC CONDITIONS.....	2
4.1	Artificial Fill	2
4.2	Alluvium	3
5.	GROUNDWATER.....	3
6.	GEOLOGIC HAZARDS.....	4
6.1	Surface Fault Rupture	4
6.2	Seismicity.....	5
6.3	Seismic Design Criteria	5
6.4	Liquefaction Potential.....	7
6.5	Seismically Induced Dry Settlement.....	9
6.6	Lateral Spreading.....	9
6.7	Slope Stability.....	9
6.8	Earthquake-Induced Flooding.....	10
6.9	Tsunamis, Seiches, and Flooding.....	10
6.10	Oil Fields & Methane Potential	10
6.11	Subsidence	11
7.	CONCLUSIONS AND RECOMMENDATIONS.....	12
7.1	General.....	12
7.2	Soil and Excavation Characteristics.....	15
7.3	Minimum Resistivity, pH and Water-Soluble Sulfate	16
7.4	Grading	16
7.5	Shrinkage	19
7.6	Mat Foundation Design.....	19
7.7	Post-Tensioned Foundation Recommendations.....	20
7.8	Foundation Settlement	23
7.9	Miscellaneous Foundations.....	23
7.10	Lateral Design.....	24
7.11	Concrete Slabs-on-Grade	24
7.12	Preliminary Pavement Recommendations	26
7.13	Retaining Wall Design.....	27
7.14	Retaining Wall Drainage.....	30
7.15	Elevator Pit Design	31
7.16	Elevator Piston.....	31
7.17	Temporary Excavations	31
7.18	Stormwater Infiltration.....	32
7.19	Site Drainage and Moisture Protection	34
7.20	Plan Review	35

LIMITATIONS AND UNIFORMITY OF CONDITIONS

LIST OF REFERENCES

TABLE OF CONTENTS (Continued)

MAPS, TABLES, AND ILLUSTRATIONS

Figure 1, Vicinity Map

Figure 2, Site Plan

Figure 3, Regional Fault Map

Figure 4, Regional Seismicity Map

Figures 5 through 8, DE Empirical Estimation of Liquefaction Potential

Figures 9 through 12, MCE Empirical Estimation of Liquefaction Potential

Figures 13 through 16, Evaluation of Earthquake-Induced Settlements

Figures 17 and 18, Retaining Wall Drain Detail

Figure 19, Percolation Test Results

APPENDIX A

FIELD INVESTIGATION

Figures A1 through A5, Boring Logs

APPENDIX B

LABORATORY TESTING

Figures B1 through B4, Direct Shear Test Results

Figures B5 through B22, Consolidation Test Results

Figures B23 and B24, Grain Size Analysis

Figures B25 and B26, Compaction Characteristics Using Modified Effort Test Results

Figures B27 and B28, Expansion Index Test Results

Figure B29, Corrosivity Test Results

GEOTECHNICAL INVESTIGATION

1. PURPOSE AND SCOPE

This report presents the results of geotechnical investigation for the proposed multi-family residential development located at 910 South Mariposa Street in the City of Burbank, California (see Vicinity Map, Figure 1). The purpose of our investigation was to evaluate the subsurface soil and geologic conditions underlying the site and, based on conditions encountered, to provide conclusions and recommendations pertaining to geotechnical aspects of proposed design and construction.

The scope of this investigation included a site reconnaissance, field exploration, laboratory testing, engineering analysis, and the preparation of this report. The site was explored on December 1, 2022, by excavating three 7-inch diameter borings to a maximum depth of approximately 55½ feet below the existing ground surface using utilizing a truck-mounted hollow-stem auger drilling machine and two 3½ inch diameter borings to a maximum depth of 15½ feet below the ground surface using manual auger equipment. The approximate locations of the exploratory borings are depicted on the Site Plan (see Figure 2). A detailed discussion of the field investigation, including boring logs, is presented in Appendix A.

Laboratory tests were performed on selected soil samples obtained during the investigation to determine pertinent physical and chemical soil properties. Appendix B presents a summary of the laboratory test results.

The recommendations presented herein are based on analysis of the data obtained during the investigation and our experience with similar soil and geologic conditions. References reviewed to prepare this report are provided in the *List of References* section.

If project details vary significantly from those described herein, Geocon should be contacted to determine the necessity for review and possible revision of this report.

2. SITE AND PROJECT DESCRIPTION

The subject site is located at 910 South Mariposa Street in the City of Burbank, California. The approximately one-acre site is currently being used to stable horses and is occupied by covered stable areas, horse corrals, and several single-story structures. The parcel is bounded by another commercial structure to the north, by a powerline easement to the east, horse corral structure to the south, and South Mariposa Street and single-family residential structures to the west. The site is relatively level, with no pronounced highs or lows. Surface water drainage at the site appears to be by sheet flow along the existing ground contours to the city streets or local area drains.

Based on the information provided by the Client, it is our understanding that the proposed development will consist of several three-story townhouse structures that will be constructed at or near present site grade. The proposed site conditions are depicted on the Site Plan (see Figure 2).

Based on the preliminary nature of the design at this time, wall and column loads were not available. It is anticipated that column loads for the three-story residential structures will be up to 200 kips. It is anticipated that wall loads will be up to 2.5 kips per linear foot.

Once the design phase and foundation loading configuration proceeds to a more finalized plan, the recommendations within this report should be reviewed and revised, if necessary. Any changes in the design, location or elevation of any structure, as outlined in this report, should be reviewed by this office. Geocon should be contacted to determine the necessity for review and possible revision of this report.

3. GEOLOGIC SETTING

The site is located in the southeastern portion of the San Fernando Valley, an alluvial-filled basin approximately 23 miles wide and 12 miles long (Hitchcock and Wills, 2000). The alluvium within the San Fernando Valley is mainly derived from the Santa Monica Mountains to the south-southwest, the Verdugo Mountains to the northeast, the Simi Hills to the northwest, and the San Gabriel Mountains to the northeast. The channelized Los Angeles River is located approximately 100 feet south of the site. Locally, the site is situated on the Los Angeles River flood plain and, based on published geologic maps, the site is underlain by late Pleistocene to early Holocene alluvial deposits. Regionally, the site is located in the southern portion of the Transverse Ranges geomorphic province. This province is characterized by east-west trending geologic structures such as the nearby Santa Monica Mountains and the east-west trending active San Fernando Fault Zone.

4. SOIL AND GEOLOGIC CONDITIONS

Based on our field investigation and published geologic maps of the area, the site is underlain by artificial fill and late Pleistocene to early Holocene age alluvial deposits (CGS, 2012). Detailed stratigraphic profiles of the materials encountered at the site are provided on the boring logs in Appendix A.

4.1 Artificial Fill

Artificial fill was encountered in our explorations to a maximum depth of 9 feet below existing ground surface. The artificial fill generally consists of olive brown to yellowish brown sandy silt and silty sand. The artificial fill is characterized as fine- to medium-grained, slightly moist to moist, and loose to medium dense, or soft to firm. The fill is likely the result of past grading or construction activities at the site. Deeper fill may exist between excavations and in other portions of the site that were not directly explored.

4.2 Alluvium

Late Pleistocene to early Holocene age alluvium was encountered beneath the fill. The alluvium generally consists of brown to grayish brown, gray, or olive brown interbedded silt and sand with varying amounts of silt and fine to coarse gravel. Borings B1 and B2 encountered very dense poorly graded to well-graded sand at depths below approximately 25 to 26 feet to the bottom of borings. The alluvial soils are characterized as slightly moist to moist and very loose to very dense or very soft to hard.

5. GROUNDWATER

The Seismic Hazard Evaluation Report for the Burbank Quadrangle (California Division of Mines and Geology [CDMG], 1998) indicates the historically highest groundwater level in the area is approximately 20 feet beneath the existing ground surface. Groundwater information presented in this document is generated from data collected in the early 1900's to the late 1990s. However, more recent information from the City of Burbank Safety Element (2013) indicates that groundwater extraction has resulted in lower groundwater depths and concludes, based on the last 60 years of groundwater monitoring well data, that groundwater levels are expected to remain deeper than 50 feet beneath the ground surface in the vicinity of the site. Consequently, based on current groundwater management practices, current and future groundwater levels are not expected to reach historic high levels.

Groundwater was not encountered in our borings, drilled to a maximum depth of approximately 55½ feet below the existing ground surface. Based on the reported historic high groundwater levels in the site vicinity (CDMG, 1998), the lack of groundwater in our borings, and the depth of proposed construction, static groundwater is neither expected to be encountered during construction, nor have a detrimental effect on the project. However, it is not uncommon for groundwater levels to vary seasonally or for groundwater seepage conditions to develop where none previously existed, especially in impermeable fine-grained soils which are heavily irrigated or after seasonal rainfall. In addition, recent requirements for stormwater infiltration could result in shallower seepage conditions in the immediate site vicinity. Proper surface drainage of irrigation and precipitation will be critical for future performance of the project. Recommendations for drainage are provided in the *Site Drainage and Moisture Protection* section of this report (see Section 7.19).

6. GEOLOGIC HAZARDS

6.1 Surface Fault Rupture

The numerous faults in Southern California include Holocene-active, pre-Holocene, and inactive faults. The criteria for these major groups are based on criteria developed by the California Geological Survey (CGS, formerly known as CDMG) for the Alquist-Priolo Earthquake Fault Zone Program (CGS, 2018). By definition, a Holocene-active fault is one that has had surface displacement within Holocene time (about the last 11,700 years). A pre-Holocene fault has demonstrated surface displacement during Quaternary time (approximately the last 1.6 million years) but has had no known Holocene movement. Faults that have not moved in the last 1.6 million years are considered inactive.

The site is not within a state-designated Alquist-Priolo Earthquake Fault Zone for surface fault rupture hazards (CDMG, 1979; CGS, 2022a, 2022b). No Holocene-active or pre-Holocene faults with the potential for surface fault rupture are known to pass directly beneath the site. Therefore, the potential for surface rupture due to faulting occurring beneath the site during the design life of the proposed development is considered low. However, the site is located in the seismically active Southern California region and could be subjected to moderate to strong ground shaking in the event of an earthquake on one of the many active Southern California faults. The faults in the vicinity of the site are shown in Figure 3, Regional Fault Map.

The closest surface trace of an active fault to the site is the Verdugo Fault located approximately 2.6 miles to the northeast (CDMG, 1979; USGS, 2006; Ziony and Jones, 1989). Other nearby active faults are the Hollywood Fault, an unnamed fault, the Raymond Fault, the Santa Monica Fault, the San Fernando Fault Zone, and the Newport-Inglewood Fault Zone located approximately 3.1 miles south, 3.1 miles west-northwest, 5.2 miles southeast, 7.3 miles southwest, 7.9 miles north and 8.0 miles southwest of the site, respectively (USGS, 2006; Ziony and Jones, 1989). The active San Andreas Fault Zone is located approximately 29 miles northeast of the site (USGS, 2006).

Several buried thrust faults, commonly referred to as blind thrusts, underlie the Los Angeles Basin and the San Fernando Valley at depth. These faults are not exposed at the ground surface and are typically identified at depths greater than 3.0 kilometers. The October 1, 1987 M_w 5.9 Whittier Narrows earthquake and the January 17, 1994 M_w 6.7 Northridge earthquake were a result of movement on the Puente Hills Blind Thrust and the Northridge Thrust, respectively. These thrust faults and others in the Southern California area are not exposed at the surface and do not present a potential surface fault rupture hazard at the site; however, these deep thrust faults are considered active features capable of generating future earthquakes that could result in moderate to significant ground shaking at the site.

6.2 Seismicity

As with all of Southern California, the site has experienced historic earthquakes from various regional faults. The seismicity of the region surrounding the site was formulated based on research of an electronic database of earthquake data. The epicenters of recorded earthquakes with magnitudes equal to or greater than 5.0 in the site vicinity are depicted on Figure 4, Regional Seismicity Map. A partial list of moderate to major magnitude earthquakes that have occurred in the Southern California area within the last 100 years is included in the following table.

LIST OF HISTORIC EARTHQUAKES

Earthquake (Oldest to Youngest)	Date of Earthquake	Magnitude	Distance to Epicenter (Miles)	Direction to Epicenter
Near Redlands	July 23, 1923	6.3	62	E
Long Beach	March 10, 1933	6.4	42	SE
Tehachapi	July 21, 1952	7.5	71	NW
San Fernando	February 9, 1971	6.6	18	NNW
Whittier Narrows	October 1, 1987	5.9	15	ESE
Sierra Madre	June 28, 1991	5.8	19	ENE
Landers	June 28, 1992	7.3	107	E
Big Bear	June 28, 1992	6.4	85	E
Northridge	January 17, 1994	6.7	13	WNW
Hector Mine	October 16, 1999	7.1	120	ENE
Ridgecrest	July 5, 2019	7.1	118	NNE

The site could be subjected to strong ground shaking in the event of an earthquake. However, this hazard is common in Southern California and the effects of ground shaking can be minimized if the proposed structures are designed and constructed in conformance with current building codes and engineering practices.

6.3 Seismic Design Criteria

The following table summarizes the site-specific design criteria obtained from the 2022 California Building Code (CBC; Based on the 2021 International Building Code [IBC] and ASCE 7-16), Chapter 16 Structural Design, Section 1613 Earthquake Loads. The data was calculated using the online application *U.S. Seismic Design Maps*, provided by the Structural Engineers Association of California (SEAOC). The short spectral response uses a period of 0.2 second. We evaluated the Site Class based on the discussion in Section 1613.2.2 of the 2022 CBC and Table 20.3-1 of ASCE 7-16. The values presented below are for the risk-targeted maximum considered earthquake (MCE_R).

Although there are liquefiable underlying the site, we expect the building possesses a fundamental period of less than 0.5 seconds; therefore, a site response analysis is not anticipated to be required in accordance with ASCE 7-16, Section 20.3.1.

2022 CBC SEISMIC DESIGN PARAMETERS

Parameter	Value	2022 CBC Reference
Site Class	D	Section 1613.2.2
MCE _R Ground Motion Spectral Response Acceleration – Class B (short), S _S	2.1g	Figure 1613.2.1(1)
MCE _R Ground Motion Spectral Response Acceleration – Class B (1 sec), S _I	0.745g	Figure 1613.2.1(2)
Site Coefficient, F _A	1	Table 1613.2.3(1)
Site Coefficient, F _V	1.7	Table 1613.2.3(2)
Site Class Modified MCE _R Spectral Response Acceleration (short), S _{MS}	2.1g	Section 1613.2.3 (Eqn 16-36)
Site Class Modified MCE _R Spectral Response Acceleration – (1 sec), S _{M1}	1.267g*	Section 1613.2.3 (Eqn 16-37)
5% Damped Design Spectral Response Acceleration (short), S _{DS}	1.4g	Section 1613.2.4 (Eqn 16-38)
5% Damped Design Spectral Response Acceleration (1 sec), S _{D1}	0.845g*	Section 1613.2.4 (Eqn 16-39)
*Per Supplement 3 of ASCE7-16, a ground motion hazard analysis (GMHA) shall be performed for projects on Site Class “D” sites with 1-second spectral acceleration (S _I) greater than or equal to 0.2g, which is true for this site. However, Supplement 3 of ASCE 7-16 provides an exception stating that that the GMHA may be waived provided that the parameter S _{M1} is increased by 50% for all applications of S _{M1} . The values for parameters S _{M1} and S _{D1} presented above have not been increased in accordance with Supplement 3 of ASCE 7-16.		

The table below presents the mapped maximum considered geometric mean (MCE_G) seismic design parameters for projects located in Seismic Design Categories of D through F in accordance with ASCE 7-16.

ASCE 7-16 PEAK GROUND ACCELERATION

Parameter	Value	ASCE 7-16 Reference
Mapped MCE _G Peak Ground Acceleration, PGA	0.894g	Figure 22-9
Site Coefficient, F _{PGA}	1.1	Table 11.8-1
Site Class Modified MCE _G Peak Ground Acceleration, PGAM	0.983g	Section 11.8.3 (Eqn 11.8-1)

The Maximum Considered Earthquake Ground Motion (MCE) is the level of ground motion that has a 2 percent chance of exceedance in 50 years, with a statistical return period of 2,475 years. According to the 2022 California Building Code and ASCE 7-16, the MCE is to be utilized for the evaluation of liquefaction, lateral spreading, seismic settlements, and it is our understanding that the intent of the Building Code is to maintain “Life Safety” during a MCE event. The Design Earthquake Ground Motion (DE) is the level of ground motion that has a 10 percent chance of exceedance in 50 years, with a statistical return period of 475 years.

Deaggregation of the MCE peak ground acceleration was performed using the USGS online Unified Hazard Tool, 2014 Conterminous U.S. Dynamic edition (v4.2.0). The result of the deaggregation analysis indicates that the predominant earthquake contributing to the MCE peak ground acceleration is characterized as a 6.94 magnitude event occurring at a hypocentral distance of 9.05 kilometers from the site.

Deaggregation was also performed for the Design Earthquake (DE) peak ground acceleration, and the result of the analysis indicates that the predominant earthquake contributing to the DE peak ground acceleration is characterized as a 6.81 magnitude occurring at a hypocentral distance of 13.02 kilometers from the site.

Conformance to the criteria in the above tables for seismic design does not constitute any kind of guarantee or assurance that significant structural damage or ground failure will not occur if a large earthquake occurs. The primary goal of seismic design is to protect life, not to avoid all damage, since such design may be economically prohibitive.

6.4 Liquefaction Potential

Liquefaction is a phenomenon in which loose, saturated, relatively cohesionless soil deposits lose shear strength during strong ground motions. Primary factors controlling liquefaction include intensity and duration of ground motion, gradation characteristics of the subsurface soils, in-situ stress conditions, and the depth to groundwater. Liquefaction is typified by a loss of shear strength in the liquefied layers due to rapid increases in pore water pressure generated by earthquake accelerations.

The current standard of practice, as outlined in the “Recommended Procedures for Implementation of DMG Special Publication 117, Guidelines for Analyzing and Mitigating Liquefaction in California” and “Special Publication 117A, Guidelines for Evaluating and Mitigating Seismic Hazards in California” requires liquefaction analysis to a depth of 50 feet below the lowest portion of the proposed structure. Liquefaction typically occurs in areas where the soils below the water table are composed of poorly consolidated, fine- to medium-grained, primarily sandy soil. In addition to the requisite soil conditions, the ground acceleration and duration of the earthquake must also be of a sufficient level to induce liquefaction.

A review of the State of California Seismic Hazard Zone Map for the Burbank Quadrangle (CDMG, 1999) indicates that the site is located within an area identified as having a potential for liquefaction. Also, according to the City of Burbank Safety Element (2013), the site is located within an area identified as having a potential for liquefaction. The reported historic high ground level is at a depth of approximately 20 feet beneath the existing ground surface (CDMG, 1998).

As indicated in the *Groundwater* section of this report (see Section 5), based on current groundwater management practices, current and future groundwater levels are not expected to reach historic high levels. In addition, the City of Burbank Safety Element (2013) reports that groundwater extraction has resulted in lower groundwater depths and concludes, based on the last 60 years of groundwater monitoring well data, that groundwater levels are not expected to return to historic high levels.

Liquefaction analysis of the soils underlying the site was performed using an updated version of the spreadsheet template LIQ2_30.WQ1 developed by Thomas F. Blake (1996). This program utilizes the 1996 NCEER method of analysis. This semi-empirical method is based on a correlation between values of Standard Penetration Test (SPT) resistance and field performance data. In order to supplement the SPT blow count data, select California Modified Sampler blow count data were converted to equivalent SPT blow counts based on a correlation factor of 0.55 (Rogers, 2006).

The liquefaction analysis was performed for a Design Earthquake level by using a historic high groundwater table of 20 feet below the ground surface, a magnitude 6.81 earthquake, and a peak horizontal acceleration of 0.656g ($\frac{2}{3}$ PGA_M). The enclosed liquefaction analyses, included herein for borings B1 and B2, indicate that the alluvial soils below the historic high groundwater level could be susceptible to up to 0.6 inch and 0.3 inch, respectively, of liquefaction settlement during Design Earthquake ground motion (see enclosed calculation sheets, Figures 5 through 8).

It is our understanding that the intent of the Building Code is to maintain “Life Safety” during Maximum Considered Earthquake level events. Therefore, additional analysis was performed to evaluate the potential for liquefaction during a MCE event. The structural engineer should evaluate the proposed structure for the anticipated MCE liquefaction induced settlements and verify that anticipated deformations would not cause the foundation system to lose the ability to support the gravity loads and/or cause collapse of the structure.

The liquefaction analysis was also performed for the Maximum Considered Earthquake level by using a historic high groundwater table of 50 feet below the ground surface, a magnitude 6.94 earthquake, and a peak horizontal acceleration of 0.983g (PGA_M). The enclosed liquefaction analysis, included herein for borings B1 and B2, indicate that the alluvial soils below the historic high groundwater level could be susceptible up to 0.6 inch and 0.3 inch, respectively, of liquefaction settlement during Maximum Considered Earthquake ground motion (see enclosed calculation sheets, Figures 9 through 12).

6.5 Seismically Induced Dry Settlement

Dynamic compaction of dry and loose sands may occur during a major earthquake. Typically, settlements occur in thick beds of such soils. The seismically induced settlement calculations were performed in accordance with the American Society of Civil Engineers, Technical Engineering and Design Guides as adapted from the US Army Corps of Engineers, No. 9.

The calculations provided herein for borings B1 and B2 indicate that the alluvial soils could be susceptible to approximately 0.13 and 0.27 inch, respectively, of seismically induced dry settlement as a result of the Design Earthquake peak ground acceleration ($\frac{2}{3}PGA_M$).

The calculations provided herein for borings B1 and B2 indicate that the alluvial soils could be prone to approximately 0.35 inch and 1.73 inches, respectively, of seismically induced dry settlement as a result of the Maximum Considered Earthquake ground acceleration (PGA_M).

Calculations of the anticipated seismically induced dry settlements are provided as Figures 13 through 16.

6.6 Lateral Spreading

Lateral spread typically occurs where an unconfined slope is present or where liquefiable soils are located on a gently sloping ground surface. The existing drainage channel is a concrete lined channel. Due to the relatively level ground surface at the site and the confined configuration of the channel, the potential for lateral spreading is considered low.

6.7 Slope Stability

The topography at the site is relatively level and the topography in the immediate site vicinity slopes gently to the south-southeast. The City of Burbank Safety Element (2013) and the County of Los Angeles Safety Element (Leighton, 1990) indicate that the site is not located within an area identified as having a potential for slope stability hazards. Additionally, the State of California Seismic Hazard Zones Map for the Burbank Quadrangle (CDMG, 1999) indicates that site is not located within an area identified as having a potential for seismic slope instability. There are no known landslides near the site, nor is the site in the path of any known or potential landslides. Therefore, the potential for slope stability hazards to adversely affect the proposed development is considered low.

6.8 Earthquake-Induced Flooding

Earthquake-induced flooding is inundation caused by failure of dams or other water-retaining structures due to earthquakes. The Los Angeles County Safety Element (Leighton, 1990) indicates that the site is located within the Hansen Dam inundation area. However, this reservoir, as well as others in California, are continually monitored by various governmental agencies (such as the State of California Division of Safety of Dams and the U.S. Army Corps of Engineers) to guard against the threat of dam failure. Current design, construction practices, and ongoing programs of review, modification, or total reconstruction of existing dams are intended to ensure that all dams are capable of withstanding the maximum considered earthquake (MCE) for the site. Therefore, the potential for inundation at the site as a result of an earthquake-induced dam failure is considered low.

6.9 Tsunamis, Seiches, and Flooding

The site is not located within a coastal area. Therefore, tsunamis are not considered a significant hazard at the site.

Seiches are large waves generated in enclosed bodies of water in response to ground shaking. No major water-retaining structures are located immediately up gradient from the project site. Therefore, flooding resulting from a seismically induced seiche is considered unlikely.

The site is within an area of minimal flooding (Zone X) as defined by the Federal Emergency Management Agency (FEMA, 2022; LACDPW, 2022b).

6.10 Oil Fields & Methane Potential

Based on a review of the California Geologic Energy Management Division (CalGEM) Well Finder Website, the site is not located within an oil field and there are no oil or gas wells documented at the site or within $\frac{1}{4}$ -mile of the site (CalGEM, 2022). However, due to the voluntary nature of record reporting by the oil well drilling companies, wells may be improperly located or not shown on the location map and undocumented wells could be encountered during construction. Any wells encountered will need to be properly abandoned in accordance with the current requirements of the CalGEM.

Since the site is not located within the boundaries of a known oil field, the potential for the presence of methane or other volatile gases at the site is considered low. However, should it be determined that a methane study is required for the proposed development it is recommended that a qualified methane consultant be retained to perform the study and provide mitigation measures as necessary.

6.11 Subsidence

Subsidence occurs when a large portion of land is displaced vertically, usually due to the withdrawal of groundwater, oil, or natural gas. Soils that are particularly subject to subsidence include those with high silt or clay content. The site is not located within an area of known ground subsidence (USGS, 2022). No large-scale extraction of groundwater, gas, oil, or geothermal energy is occurring or planned at the site or in the general site vicinity. There appears to be little or no potential for ground subsidence due to withdrawal of fluids or gases at the site.

7. CONCLUSIONS AND RECOMMENDATIONS

7.1 General

- 7.1.1 It is our opinion that neither soil nor geologic conditions were encountered during the investigation that would preclude the construction of the proposed structure provided the recommendations presented herein are followed and implemented during design and construction.
- 7.1.2 Up to 9 feet of artificial fill was encountered during site exploration. The existing fill encountered is believed to be the result of past grading and construction activities at the site. Deeper fill may exist in other areas of the site that were not directly explored. Future demolition of the existing structures which occupy the site will likely disturb the upper few feet of soil. It is our opinion that the existing fill, in its present condition, is not suitable for direct support of proposed foundations, slabs, or additional fill. The existing fill and site soils are suitable for re-use as engineered fill provided the recommendations in the *Grading* section of this report are followed (see Section 7.4).
- 7.1.3 The enclosed seismically-induced settlement analyses indicate that the alluvial soils underlying the site could be susceptible to up to 0.73 inch of total settlement as a result of the Design Earthquake peak ground acceleration ($\frac{2}{3}PG_{AM}$). Differential settlement at the foundation level is anticipated to be less than 0.37 inch over a distance of 20 feet. The foundation design recommendations presented herein are intended to reduce the effects of settlement on proposed improvements.
- 7.1.4 The results of laboratory testing indicate that the existing upper site soils in the are moderately compressible, which in its current condition could yield excessive static and differential settlements when subject to foundation loading. The grading and foundation recommendations presented herein are intended to mitigate the effects of settlement on the proposed structure.

- 7.1.5 Based on these considerations, as a minimum, it is recommended that the upper 5 feet of existing earth materials from existing grade and within the proposed building footprint areas be excavated and properly compacted for foundation and slab support. Deeper excavations should be conducted to remove any encountered existing artificial fill or soft soils as necessary at the direction of the Geotechnical Engineer (a representative of Geocon). The Client and grading contractor should be aware that the encountered existing artificial fill is 9 feet deep below the existing ground surface in Boring 5. Proposed building foundations should be underlain by a minimum of 3 feet of newly placed engineered fill. The excavation should extend laterally a minimum distance of 3 feet beyond the building footprint area, including building appurtenances, or a distance equal to the depth of fill below the foundation, whichever is greater. The limits of existing fill and/or soft soil removal will be verified by the Geocon representative during site grading activities. Recommendations for earthwork are provided in the *Grading* section of this report (see Section 7.4).
- 7.1.6 Additional grading should be conducted as necessary to maintain the required 3 feet of newly placed engineered fill below foundations. The grading contractor should verify all bottom of footing elevations prior to commencement of grading activities to ensure that grading is conducted deep enough to provide the required three foot of engineering fill below foundations.
- 7.1.7 Prior to placing any fill, the upper twelve inches of the excavation bottom must be proof-rolled with heavy equipment in the presence of the Geotechnical Engineer (a representative of Geocon).
- 7.1.8 Subsequent to the recommended grading, the proposed structure may be supported on a mat foundation system or a post-tensioned foundation system deriving support exclusively in newly placed engineered fill. Recommendations for the design of a mat foundation system are provided in Section 7.6, and recommendations for the design of a post-tensioned foundation system are provided in Section 7.7.
- 7.1.9 It is recommended that flexible utility connections be utilized for all rigid utilities to minimize or prevent damage to utilities from minor differential movements.

- 7.1.10 All excavations must be observed and approved in writing by the Geotechnical Engineer (a representative of Geocon). There is a potential for localized areas of soft soils to be exposed at the excavation bottom. It is recommended that the entire excavation bottom be proof-rolled and stabilized as necessary prior to placement of engineered fill. Prior to placing any fill, the excavation must be observed and approved in writing by the Geotechnical Engineer (a representative of Geocon). If determined to be excessively soft, stabilization of the bottom of the excavation may be required in order to provide a firm working surface upon which engineered fill can be placed and heavy equipment can operate. Recommendations for earthwork and soil stabilization are provided in the *Grading* section of this report (see Section 7.4).
- 7.1.11 It is anticipated that stable excavations for the recommended grading associated with the proposed structures can be achieved with sloping measures. However, if excavations in close proximity to an adjacent property line and/or structure are required, special excavation measures, such as slot-cutting or shoring, may be necessary in order to maintain lateral support of offsite improvements. Excavation recommendations are provided in the *Temporary Excavations* section of this report (Section 7.17).
- 7.1.12 Foundations for small outlying structures, such as block walls up to 6 feet in height, planter walls or trash enclosures, which will not be tied to the proposed structure, may be supported on conventional foundations deriving support on a minimum of 12 inches of newly placed engineered fill, which extends laterally at least 12 inches beyond the foundation area. Where excavation and compaction cannot be performed, such as adjacent to property lines, foundations may be deepened as necessary to maintain a minimum 12-inch embedment into the undisturbed alluvial soils. If the soils exposed in the excavation bottom are soft or loose, compaction of the soils will be required prior to placing steel or concrete. Compaction of the foundation excavation bottom is typically accomplished with a compaction wheel or mechanical whacker and must be observed and approved by a Geocon representative.
- 7.1.13 Where new paving is to be placed, it is recommended that all existing fill and soft soils be excavated and properly compacted for paving support. The client should be aware that excavation and compaction of all existing fill and soft soils in the area of new paving is not required; however, paving constructed over existing uncertified fill or unsuitable soil may experience increased settlement and/or cracking, and may therefore have a shorter design life and increased maintenance costs. As a minimum, the upper 12 inches of subgrade soil should be scarified and properly compacted for paving support. Paving recommendations are provided in *Preliminary Pavement Recommendations* section of this report (see Section 7.12).

- 7.1.14 Based on the results of percolation testing performed at the site, stormwater infiltration system is considered feasible for this project. A summary of the percolation test results is provided in the *Stormwater Infiltration* section of this report (see Section 7.18).
- 7.1.15 Once the design and foundation loading configuration for the proposed structure proceeds to a more finalized plan, the recommendations within this report should be reviewed and revised, if necessary. Based on the final foundation loading configurations, the potential for settlement should be re-evaluated by this office.
- 7.1.16 Any changes in the design, location or elevation, as outlined in this report, should be reviewed by this office. Geocon should be contacted to determine the necessity for review and possible revision of this report.
- 7.1.17 The most recent ASTM standards apply to this project and must be utilized, even if older ASTM standards are indicated in this report.

7.2 Soil and Excavation Characteristics

- 7.2.1 The in-situ soils can be excavated with moderate effort using conventional excavation equipment. Caving should be anticipated in unshored excavations, especially where granular soils are present.
- 7.2.2 It is the responsibility of the contractor to ensure that all excavations and trenches are properly shored and maintained in accordance with applicable OSHA rules and regulations to maintain safety and maintain the stability of existing adjacent improvements.
- 7.2.3 All onsite excavations must be conducted in such a manner that potential surcharges from existing structures, construction equipment, and vehicle loads are resisted. The surcharge area may be defined by a 1:1 projection down and away from the bottom of an existing foundation or vehicle load. Penetrations below this 1:1 projection will require special excavation measures such as sloping or shoring. Excavation recommendations are provided in the *Temporary Excavations* section of this report (see Section 7.17).
- 7.2.4 The soils encountered at foundation levels are considered to be “non-expansive” ($EI < 20$) as defined by 2022 California Building Code (CBC) Section 1803.5.3. Recommendations presented herein assume that the foundations and slabs will derive support in these materials.

7.3 Minimum Resistivity, pH and Water-Soluble Sulfate

7.3.1 Potential of Hydrogen (pH) and resistivity testing as well as chloride content testing were previously performed on representative samples of soil to generally evaluate the corrosion potential to surface utilities. The tests were performed in accordance with California Test Method Nos. 643 and 422 and indicate that the soils are considered “severely corrosive” with respect to corrosion of buried ferrous metals on site. The results are presented in Appendix B (Figure B29) and should be considered for design of underground structures. Due to the corrosive potential of the soils, it is recommended that PVC, ABS or other approved plastic piping be utilized in lieu of cast-iron when in direct contact with the site soils.

7.3.2 Laboratory tests were performed on representative samples of the site materials to measure the percentage of water-soluble sulfate content. Results from the laboratory water-soluble sulfate tests are presented in Appendix B (Figure B29) and indicate that the on-site materials possess a sulfate exposure class of “S0” to concrete structures as defined by 2022 CBC Section 1904 and ACI 318 Table 19.3.1.1.

7.3.3 Geocon West, Inc. does not practice in the field of corrosion engineering. If corrosion sensitive improvements are planned, it is recommended that a corrosion engineer be retained to evaluate corrosion test results and incorporate the necessary precautions to avoid premature corrosion on buried metal pipes and concrete structures in direct contact with the soils.

7.4 Grading

7.4.1 Grading is anticipated to include preparation of building pads, excavation of site soils for proposed foundations and utility trenches and placement of backfill for utility trenches.

7.4.2 Earthwork should be observed, and compacted fill tested by representatives of Geocon West, Inc. The existing fill and alluvial soil encountered during exploration is suitable for re-use as engineered fill, provided any encountered oversize material (greater than 6 inches) and any encountered deleterious debris are removed.

7.4.3 A preconstruction conference should be held at the site prior to the beginning of grading operations with the owner, contractor, civil engineer, geotechnical engineer, and, if applicable, building official in attendance. Special soil handling requirements can be discussed at that time.

- 7.4.4 Grading should commence with the removal of all existing vegetation and existing improvements from the area to be graded. Deleterious debris such as wood and root structures should be exported from the site and should not be mixed with the fill soils. Asphalt and concrete should not be mixed with the fill soils unless approved by the Geotechnical Engineer. All existing underground improvements planned for removal should be completely excavated and the resulting depressions properly backfilled in accordance with the procedures described herein. Once a clean excavation bottom has been established it must be observed and approved in writing by the Geotechnical Engineer (a representative of Geocon West, Inc.).
- 7.4.5 As a minimum, it is recommended that the upper 5 feet of existing earth materials from existing grade and within the proposed building footprint area be excavated and properly compacted for foundation and slab support. Deeper excavations should be conducted as necessary to remove deeper artificial fill or soft alluvial soil at the direction of the Geotechnical Engineer (a representative of Geocon). The Client and grading contractor should be aware that the encountered existing artificial fill is 9 feet deep below the existing ground surface in Boring 5. Proposed building foundations should be underlain by a minimum of 3 feet of newly placed engineered fill. The engineered fill blanket should extend laterally a minimum distance of 3 feet beyond the building footprint areas, including building appurtenances, or a distance equal to the depth of fill below the foundation, whichever is greater. The limits of existing fill and/or soft soil removal will be verified by the Geocon representative during site grading activities.
- 7.4.6 Additional grading should be conducted as necessary to maintain the required 3 feet of newly placed engineered fill below foundations. The grading contractor should verify all bottom of footing elevations prior to commencement of grading activities to ensure that grading is conducted deep enough to provide the required three foot of engineering fill below foundations.
- 7.4.7 Prior to placing any fill, the excavation bottom must be proof-rolled with heavy equipment in the presence of the Geotechnical Engineer (a representative of Geocon) and approved in writing.
- 7.4.8 Bottom stabilization, if necessary, may be achieved placing a thin lift of 3- to 6-inch-diameter crushed angular rock into the soft excavation bottom. The use of crushed concrete will also be acceptable. The crushed rock should be spread thinly across the excavation bottom and pressed into the soils by track rolling or wheel rolling with heavy equipment. It is very important that voids between the rock fragments are not created so the rock must be thoroughly pressed or blended into the soils. All subgrade soils must be properly compacted and proof-rolled in the presence of the Geotechnical Engineer (a representative of Geocon West, Inc.).

- 7.4.9 An additional method of subgrade stabilization would be to place a minimum 12-inch thick layer of aggregate base over Tensar InterAx NX850 geogrid or equivalent extruded (nonwoven) geotextile. The Tensar geogrids should be installed throughout and should overlap in accordance with the manufacturer's recommendations. Prior to placing the geogrid, excessively soft or wet materials should be removed, and the resulting excavation bottom should be free of loose material. Non-vibratory compaction methods should be used for compaction of the base material. The aggregate base should be compacted to a dry density of at least 90 percent of the laboratory maximum density near the optimum moisture. If pumping of the subgrade continues, a thicker layer of aggregate base may be placed. It is very important that subgrade stabilization be performed uniformly across the entire excavation bottom.
- 7.4.10 Subsequent to the recommended grading, the proposed structures may be supported on mat foundations or post-tensioned foundation systems deriving support in newly placed engineered fill.
- 7.4.11 All fill and backfill soils should be placed in horizontal loose layers approximately 6 to 8 inches thick, moisture conditioned to near optimum moisture content and properly compacted to 90 percent of the laboratory maximum dry density in accordance with ASTM D 1557 (latest edition).
- 7.4.12 Foundations for small outlying structures, such as block walls up to 6 feet high, planter walls or trash enclosures, which will not be tied to the proposed building, may be supported on conventional foundations deriving support on a minimum of 12 inches of newly placed engineered fill which extends laterally at least 12 inches beyond the foundation area. Where excavation and proper compaction cannot be performed, foundations may derive support directly in the undisturbed alluvium, and should be deepened as necessary to maintain a minimum 12-inch embedment into the recommended bearing materials. If the soils exposed in the excavation bottom are soft or loose, compaction of the soils will be required prior to placing steel or concrete. Compaction of the foundation excavation bottom is typically accomplished with a compaction wheel or mechanical whacker and must be observed and approved by a Geocon representative.
- 7.4.13 All imported fill shall be observed, tested, and approved by Geocon West, Inc. prior to bringing soil to the site. Rocks larger than 6 inches in diameter shall not be used in the fill. Import soils used as structural fill should have an expansion index less than 20 and corrosivity properties that are equally or less detrimental to that of the existing onsite soils (see Figures B29). Import soils placed in the building area should be placed uniformly across the building pad or in a manner that is approved by the Geotechnical Engineer (a representative of Geocon).

- 7.4.14. Where new paving is to be placed, it is recommended that unsuitable or soft existing fill and alluvial soils be excavated and properly compacted for paving support. As a minimum, the upper 12 inches of subgrade soil should be scarified, moisture conditioned to near optimum moisture content, and compacted to at least 95 percent relative compaction for paving support. Paving recommendations are provided in *Preliminary Pavement Recommendations* section of this report (see Section 7.12).
- 7.4.15. It is recommended that flexible utility connections be utilized for all rigid utilities to minimize or prevent damage to utilities from minor differential movements. Utility trenches should be properly backfilled in accordance with the following requirements. The pipe should be bedded with clean sands (Sand Equivalent greater than 30) to a depth of at least 1 foot over the pipe, and the bedding material must be inspected and approved in writing by the Geotechnical Engineer (a representative of Geocon). The use of gravel is not acceptable unless used in conjunction with filter fabric to prevent the gravel from having direct contact with soil. The remainder of the trench backfill may be derived from onsite soil or approved import soil, compacted as necessary, until the required compaction is obtained. The use of minimum 2-sack slurry as backfill is also acceptable. Prior to placing any bedding materials or pipes, the excavation bottom must be observed and approved in writing by the Geotechnical Engineer (a representative of Geocon).
- 7.4.16. All trench and foundation excavation bottoms must be observed and approved in writing by the Geotechnical Engineer (a representative of Geocon), prior to placing bedding materials, fill, steel, gravel, or concrete.

7.5 Shrinkage

- 7.5.1. Shrinkage results when a volume of material removed at one density is compacted to a higher density. A shrinkage factor of approximately 25 percent should be anticipated when excavating and compacting the upper 5 feet of existing earth materials on the site to an average relative compaction of 92 percent. The grading contractor should verify shrinkage and earthwork yardage estimates.
- 7.5.2. If import soils will be utilized in the building pad, the soils must be placed uniformly and at equal thickness at the direction of the Geotechnical Engineer (a representative of Geocon West, Inc.). Soils can be borrowed from non-building pad areas and later replaced with imported soils.

7.6 Mat Foundation Design

- 7.6.1. The recommended maximum allowable bearing value is 3,500 pounds per square foot (psf). The allowable bearing pressure may be increased by up to one-third for transient loads due to wind or seismic forces.

- 7.6.2 A vertical modulus of subgrade reaction of 75 pounds per cubic inch may be used in the design of mat foundations deriving support in newly placed engineered fill. This value is a unit value for use with a 1-foot square footing. The modulus should be reduced in accordance with the following equation when used with larger foundations:

$$K_R = K \left[\frac{B+1}{2B} \right]^2$$

where: K_R = reduced subgrade modulus
 K = unit subgrade modulus
 B = foundation width (in feet)

- 7.6.3 The thickness of and reinforcement for the mat foundation should be designed by the project structural engineer.
- 7.6.4 For seismic design purposes, a coefficient of friction of 0.4 may be utilized between the concrete mat and alluvium without a moisture barrier, and 0.15 for slabs underlain by a moisture barrier.
- 7.6.5 The subgrade should be maintained at near optimum moisture content prior to and at the time of concrete placement.
- 7.6.6 Foundation excavations should be observed and approved in writing by the Geotechnical Engineer (a representative of Geocon West, Inc.), prior to the placement of reinforcing steel and concrete to verify that the exposed soil conditions are consistent with those anticipated. If unanticipated soil conditions are encountered, foundation modifications may be required.
- 7.6.7 This office should be provided a copy of the final construction plans so that the recommendations presented herein could be properly reviewed and revised if necessary.

7.7 Post-Tensioned Foundation Recommendations

- 7.7.1 The post-tensioned foundation system should be designed by a structural engineer experienced in post-tensioned slab design and design criteria of the Post-Tensioning Institute (PTI) DC 10.5-12 *Standard Requirements for Design and Analysis of Shallow Post-Tensioned Concrete Foundations on Expansive Soils* or *WRI/CRSI Design of Slab-on-Ground Foundations*, as required by the 2022 California Building Code (CBC Section 1808.6.2). Although this procedure was developed for expansive soil conditions, we understand it can also be used to reduce the potential for foundation distress due to differential settlement. The post-tensioned design should incorporate the geotechnical parameters presented in the following table, which are based on the guidelines presented in the PTI DC 10.5 design manual.

POST-TENSIONED FOUNDATION SYSTEM DESIGN PARAMETERS

Post-Tensioning Institute (PTI) DC 10.5-12 Design Parameters for Foundation Category Type I	Value
Thornthwaite Index	-20
Equilibrium Suction	3.9
Edge Lift Moisture Variation Distance, e_M (feet)	5.3
Edge Lift, y_M (inches)	1.1
Center Lift Moisture Variation Distance, e_M (feet)	9.0
Center Lift, y_M (inches)	0.47

7.7.2 The foundations for the post-tensioned slabs should be embedded in accordance with the recommendations of the structural engineer. If a post-tensioned foundation system is planned, the foundation should possess a thickened edge with a minimum width of 12 inches and extend below the clean sand or crushed rock layer. A graphic depicting the foundation embedment is provided below.

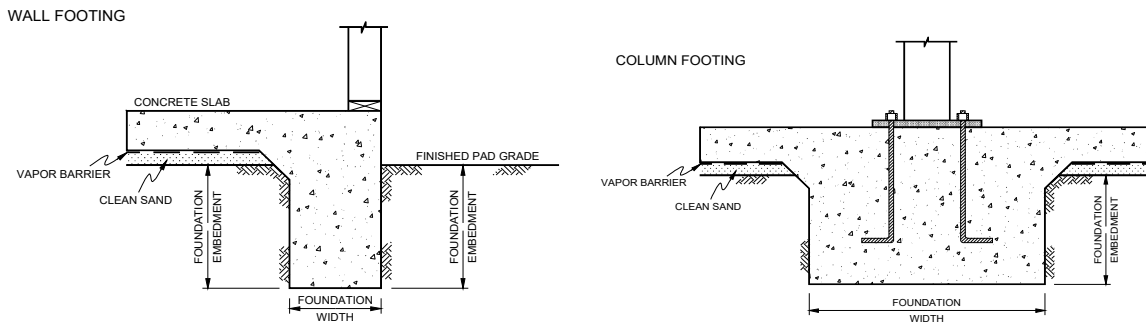

7.7.3 If the structural engineer proposes a post-tensioned foundation design method other than PTI DC 10.5:

- The deflection criteria presented in the above table are still applicable.
- Interior stiffener beams should be used.
- The width of the perimeter foundations should be at least 12 inches.
- The perimeter footing embedment depths should be at least 24 inches. The embedment depths should be measured from the lowest adjacent pad grade.

7.7.4 During the construction of the post-tension foundation system, the concrete should be placed monolithically. Under no circumstances should cold joints form between the footings/grade beams and the slab during the construction of the post-tension foundation system unless specifically designed by the structural engineer.

- 7.7.5 Our experience indicates post-tensioned slabs may be susceptible to excessive edge lift, regardless of the underlying soil conditions. Placing reinforcing steel at the bottom of the perimeter footings and the interior stiffener beams may mitigate this potential. The structural engineer should design the foundation system to reduce the potential of edge lift occurring for the proposed structures. Interior stiffening beams should be incorporated into the design of the foundation system in accordance with the PTI design procedures.
- 7.7.6 Post-tensioned foundations may be designed for an allowable soil bearing pressure of 3,500 psf (dead plus live load). This bearing pressure may be increased by one-third for transient loads due to wind or seismic forces.
- 7.7.7 Isolated footings, if present, should have a minimum embedment depth and width of 24 inches. The use of isolated footings, which are located beyond the perimeter of the building and support structural elements connected to the building, are not recommended. If this condition cannot be avoided, the isolated footings should be connected to the building foundation system with grade beams. In addition, consideration should be given to connecting patio slabs, which exceed 5 feet in width, to the building foundation to reduce the potential for future separation to occur.
- 7.7.8 The recommendations of this report are intended to reduce the potential for cracking of slabs and foundations due to expansive soil (if present) and/or differential settlement of fill soil with varying thicknesses. However, even with the incorporation of the recommendations presented herein, foundations, stucco walls, and slabs-on-grade placed on such conditions may still exhibit some cracking due to soil movement and/or shrinkage. The occurrence of concrete shrinkage cracks is independent of the supporting soil characteristics. Their occurrence may be reduced by limiting the slump of the concrete, proper concrete placement and curing, and by the placement of crack control joints at periodic intervals, in particular, where re-entrant slab corners occur.
- 7.7.9 Special subgrade presaturation is not deemed necessary prior to placing concrete; however, the exposed foundation and slab subgrade soil should be moisture conditioned, as necessary, to maintain a moist condition as would be expected in any such concrete placement.
- 7.7.10 Foundation excavations should be observed by the Geotechnical Engineer (a representative of Geocon West, Inc.) prior to the placement of reinforcing steel and concrete to check that the exposed soil conditions are consistent with those expected and have been extended to appropriate bearing strata. If unexpected soil conditions are encountered, foundation modifications may be required.
- 7.7.11 Geocon should be consulted to provide additional design parameters as required by the structural engineer.

7.8 Foundation Settlement

- 7.8.1 The enclosed seismically-induced settlement analysis indicates that the site soils could be susceptible to up to 0.73 inch of total settlement as a result of the Design Earthquake peak ground acceleration ($\frac{2}{3}PGA_M$). The differential settlement at the foundation level is anticipated to be less than 0.37 inch over a distance of 20 feet. These settlements are in addition to the static settlements indicated below and must be considered in the structural design.
- 7.8.2 The maximum expected static settlement for a structure supported on a mat foundation system or a post-tensioned foundation system deriving support in the recommended bearing materials and designed with a maximum bearing pressure of 3,500 psf is estimated to be less than 1 inch and occur below the heaviest loaded structural element. Settlement of the foundation system is expected to occur on initial application of loading. Differential settlement is expected to be less than $\frac{1}{2}$ inch over a distance of 20 feet.
- 7.8.3 Based on seismic considerations, the proposed structure should be designed for a combined static and seismically induced differential settlement of 0.87 inch over a distance of 20 feet.
- 7.8.4 It is recommended that flexible utility connections be utilized for all rigid utilities to minimize or prevent damage to utilities from minor differential movements.
- 7.8.5 Once the design and foundation loading configurations for the proposed structure proceeds to a more finalized plan, the estimated settlements presented in this report should be reviewed and revised, if necessary. If the final foundation loading configurations are greater than the assumed loading conditions, the potential for settlement should be reevaluated by this office.

7.9 Miscellaneous Foundations

- 7.9.1 Foundations for small outlying structures, such as block walls up to 6 feet in height, planter walls or trash enclosures, which will not be structurally supported by the proposed building, may be supported on conventional foundations deriving support on a minimum of 12 inches of newly placed engineered fill which extends laterally at least 12 inches beyond the foundation area. Where excavation and compaction cannot be performed, such as adjacent to property lines, foundations may bear in the undisturbed alluvial soils, and should be deepened as necessary to maintain a minimum 12-inch embedment into the recommended bearing materials.

7.9.2 If the soils exposed in the excavation bottom are soft, compaction of the soft soils will be required prior to placing steel or concrete. Compaction of the foundation excavation bottom is typically accomplished with a compaction wheel or mechanical whacker and must be observed and approved by a Geocon representative. Miscellaneous foundations may be designed for a bearing value of 1,500 psf and should be a minimum of 12 inches in width, 18 inches in depth below the lowest adjacent grade and 12 inches into the recommended bearing material. The allowable bearing pressure may be increased by up to one-third for transient loads due to wind or seismic forces.

7.9.3 Foundation excavations should be observed and approved in writing by the Geotechnical Engineer (a representative of Geocon West, Inc.), prior to the placement of reinforcing steel and concrete to verify that the excavations and exposed soil conditions are consistent with those anticipated.

7.10 Lateral Design

7.10.1 Resistance to lateral loading may be provided by friction acting at the base of foundations, slabs and by passive earth pressure. An allowable coefficient of friction of 0.4 may be used with the dead load forces in the competent alluvial soils or properly compacted engineered fill.

7.10.2 Passive earth pressure for the sides of foundations and slabs poured against competent alluvial soils or properly compacted engineered fill may be computed as an equivalent fluid having a density of 250 pcf with a maximum earth pressure of 2,500 psf. When combining passive and friction for lateral resistance, the passive component should be reduced by one-third.

7.11 Concrete Slabs-on-Grade

7.11.1 Concrete slabs-on-grade subject to vehicle loading should be designed in accordance with the recommendations in the *Preliminary Pavement Recommendations* section of this report (Section 7.12).

- 7.11.2 Slabs-on-grade at the ground surface that may receive moisture-sensitive floor coverings or may be used to store moisture-sensitive materials should be underlain by a vapor retarder placed directly beneath the slab. The vapor retarder and acceptable permeance should be specified by the project architect or developer based on the type of floor covering that will be installed. The vapor retarder design should be consistent with the guidelines presented in Section 9.3 of the American Concrete Institute's (ACI) Guide for Concrete Slabs that Receive Moisture-Sensitive Flooring Materials (ACI 302.2R-06) and should be installed in general conformance with ASTM E 1643 (latest edition) and the manufacturer's recommendations. A minimum thickness of 15 mils extruded polyolefin plastic is recommended; vapor retarders which contain recycled content or woven materials are not recommended. The vapor retarder should have a permeance of less than 0.01 perms demonstrated by testing before and after mandatory conditioning. The vapor retarder should be installed in direct contact with the concrete slab with proper perimeter seal. If the California Green Building Code requirements apply to this project, the vapor retarder should be underlain by 4 inches of clean aggregate. It is important that the vapor retarder be puncture resistant since it will be in direct contact with angular gravel. As an alternative to the clean aggregate suggested in the California Green Building Code, it is our opinion that the concrete slab-on-grade may be underlain by a vapor retarder over 4 inches of clean sand (sand equivalent greater than 30), since the sand will serve a capillary break and will minimize the potential for punctures and damage to the vapor barrier.
- 7.11.3 For seismic design purposes, a coefficient of friction of 0.4 may be utilized between concrete slabs and subgrade soils without a moisture barrier, and 0.15 for slabs underlain by a moisture barrier.
- 7.11.4 Exterior slabs, not subject to traffic loads, should be at least 4 inches thick and reinforced with No. 3 steel reinforcing bars placed 18 inches on center in both horizontal directions, positioned near the slab midpoint. Prior to construction of slabs, the upper 12 inches of subgrade should be moistened to near optimum moisture content and properly compacted to at least 95 percent relative compaction, as determined by ASTM Test Method D 1557 (latest edition). Crack control joints should be spaced at intervals not greater than 10 feet and should be constructed using saw-cuts or other methods as soon as practical following concrete placement. Crack control joints should extend a minimum depth of $\frac{1}{4}$ the slab thickness. The project structural engineer should design construction joints as necessary.
- 7.11.5 The moisture content of the slab subgrade should be maintained and sprinkled as necessary to maintain a moist condition as would be expected in any concrete placement.
- 7.11.6 The recommendations of this report are intended to reduce the potential for cracking of slabs due to settlement. However, even with the incorporation of the recommendations presented

herein, foundations, stucco walls, and slabs-on-grade may exhibit some cracking due to minor soil movement and/or concrete shrinkage. The occurrence of concrete shrinkage cracks is independent of the supporting soil characteristics. Their occurrence may be reduced and/or controlled by limiting the slump of the concrete, proper concrete placement and curing, and by the placement of crack control joints at periodic intervals, in particular, where re-entrant slab corners occur.

7.12 Preliminary Pavement Recommendations

- 7.12.1 Where new paving is to be placed, it is recommended that all existing fill and soft, unsuitable soils be excavated and properly compacted for paving support. The client should be aware that excavation and compaction of all soft, unsuitable soils in the area of new paving is not required, however, paving constructed over existing unsuitable soils may experience increased settlement and/or cracking, and may therefore have a shorter design life and increased maintenance costs. As a minimum, the upper 12 inches of paving subgrade should be scarified, moisture conditioned to near optimum moisture content, and properly compacted to at least 95 percent relative compaction, as determined by ASTM Test Method D 1557 (latest edition).
- 7.12.2 The following pavement sections are based on an assumed R-Value of 20. Once site grading activities are complete, it is recommended that laboratory testing confirm the properties of the soils serving as paving subgrade prior to placing pavement.
- 7.12.3 The Traffic Indices listed below are estimates. Geocon does not practice in the field of traffic engineering. The actual Traffic Index for each area should be determined by the project civil engineer. If pavement sections for Traffic Indices other than those listed below are required, Geocon should be contacted to provide additional recommendations. Pavement thicknesses were determined following procedures outlined in the *California Highway Design Manual* (Caltrans). It is anticipated that the majority of traffic will consist of automobile and large truck traffic.

PRELIMINARY PAVEMENT DESIGN SECTIONS

Location	Estimated Traffic Index (TI)	Asphalt Concrete (inches)	Class 2 Aggregate Base (inches)
Automobile Parking and Driveways	4.0	3.0	4.0
Trash Truck & Fire Lanes	7.0	4.0	12.0

- 7.12.4 Asphalt concrete should conform to Section 203-6 of the “*Standard Specifications for Public Works Construction*” (Green Book). Class 2 aggregate base materials should conform to Section 26-1.02A of the “*Standard Specifications of the State of California, Department of Transportation*” (Caltrans). The use of Crushed Miscellaneous Base in lieu of Class 2 aggregate base is acceptable. Crushed Miscellaneous Base should conform to Section 200-2.4 of the “*Standard Specifications for Public Works Construction*” (Green Book).
- 7.12.5 Unless specifically designed and evaluated by the project structural engineer, where exterior concrete paving will be utilized for support of vehicles, it is recommended that the concrete be a minimum of 5 inches thick and be reinforced with No. 3 steel reinforcing bars placed 18 inches on center in both horizontal directions. Concrete paving supporting vehicular traffic should be underlain by a minimum of 12 inches properly compacted subgrade soil. The subgrade and base materials should be compacted to 95 percent relative compaction, as determined by ASTM Test Method D 1557 (latest edition).
- 7.12.6 The performance of pavements is highly dependent upon providing positive surface drainage away from the edge of pavements. Ponding of water on or adjacent to the pavement will likely result in saturation of the subgrade materials and subsequent cracking, subsidence and pavement distress. If planters are planned adjacent to paving, it is recommended that the perimeter curb be extended at least 12 inches below the bottom of the aggregate base to minimize the introduction of water beneath the paving.

7.13 Retaining Wall Design

- 7.13.1 The recommendations presented below are generally applicable to the design of rigid concrete or masonry retaining walls having a maximum height of 5 feet. In the event that walls significantly higher than 5 feet are planned, Geocon should be contacted for additional recommendations.
- 7.13.2 Retaining wall foundations may be designed in accordance with the recommendations provided in the *Mat Foundation Design* section of this report (see Section 7.6).
- 7.13.3 Retaining walls with a level backfill surface that are not restrained at the top should be designed utilizing a triangular distribution of pressure (active pressure). Restrained walls are those that are not allowed to rotate more than $0.001H$ (where H equals the height of the retaining portion of the wall in feet) at the top of the wall. Where walls are restrained from movement at the top, walls may be designed utilizing a triangular distribution of pressure (at-rest pressure). The table below presents recommended pressures to be used in retaining wall design, assuming that proper drainage will be maintained.

RETAINING WALL WITH LEVEL BACKFILL SURFACE

HEIGHT OF RETAINING WALL (Feet)	ACTIVE PRESSURE EQUIVALENT FLUID PRESSURE (Pounds Per Cubic Foot)	AT-REST PRESSURE EQUIVALENT FLUID PRESSURE (Pounds Per Cubic Foot)
Up to 5	30	61

7.13.4 The wall pressures provided above assume that the proposed retaining walls will support relatively undisturbed alluvial soils or engineered fill derived from onsite soils. If import soil will be used to backfill proposed retaining walls, revised earth pressures may be required to account for the geotechnical properties of the import soil used as engineered fill. This should be evaluated once the use of import soil is established. All imported fill shall be observed, tested, and approved by Geocon West, Inc. prior to bringing soil to the site.

7.13.5 The wall pressures provided above assume that the retaining wall will be properly drained preventing the buildup of hydrostatic pressure. If retaining wall drainage is not implemented, the equivalent fluid pressure to be used in design of undrained, restrained walls is 100 pcf for the full height of the wall. The value includes hydrostatic pressures plus buoyant lateral earth pressures. If a partially drained wall is proposed, Geocon should be contacted to provide additional recommendations.

7.13.6 Additional active pressure should be added for a surcharge condition due to sloping ground, vehicular traffic or adjacent structures and should be designed for each condition as the project progresses.

7.13.7 It is recommended that line-load surcharges from adjacent wall footings, use horizontal pressures generated from NAV-FAC DM 7.2. The governing equations are:

$$\text{For } x/H \leq 0.4$$

$$\sigma_H(z) = \frac{0.20 \times \left(\frac{z}{H}\right)}{\left[0.16 + \left(\frac{z}{H}\right)^2\right]^2} \times \frac{Q_L}{H}$$

and

$$\text{For } x/H > 0.4$$

$$\sigma_H(z) = \frac{1.28 \times \left(\frac{x}{H}\right)^2 \times \left(\frac{z}{H}\right)}{\left[\left(\frac{x}{H}\right)^2 + \left(\frac{z}{H}\right)^2\right]^2} \times \frac{Q_L}{H}$$

where x is the distance from the face of the excavation or wall to the vertical line-load, H is the distance from the bottom of the footing to the bottom of excavation or wall, z is the depth at which the horizontal pressure is desired, Q_L is the vertical line-load and $\sigma_H(z)$ is the horizontal pressure at depth z .

7.13.8 It is recommended that vertical point-loads, from construction equipment outriggers or adjacent building columns use horizontal pressures generated from NAV-FAC DM 7.2. The governing equations are:

$$\text{For } x/H \leq 0.4$$

$$\sigma_H(z) = \frac{0.28 \times \left(\frac{z}{H}\right)^2}{\left[0.16 + \left(\frac{z}{H}\right)^2\right]^3} \times \frac{Q_P}{H^2}$$

and

$$\text{For } x/H > 0.4$$

$$\sigma_H(z) = \frac{1.77 \times \left(\frac{x}{H}\right)^2 \times \left(\frac{z}{H}\right)^2}{\left[\left(\frac{x}{H}\right)^2 + \left(\frac{z}{H}\right)^2\right]^3} \times \frac{Q_P}{H^2}$$

then

$$\sigma'_H(z) = \sigma_H(z) \cos^2(1.1\theta)$$

where x is the distance from the face of the excavation/wall to the vertical point-load, H is distance from the outrigger/bottom of column footing to the bottom of excavation, z is the depth at which the horizontal pressure is desired, Q_p is the vertical point-load, $\sigma_H(z)$ is the horizontal pressure at depth z , θ is the angle between a line perpendicular to the excavation/wall and a line from the point-load to location on the excavation/wall where the surcharge is being evaluated, and $\sigma_H(z)$ is the horizontal pressure at depth z .

- 7.13.9 In addition to the recommended earth pressure, the upper 10 feet of the retaining wall adjacent to the street or driveway areas should be designed to resist a uniform lateral pressure of 100 psf, acting as a result of an assumed 300 psf surcharge behind the shoring due to normal street traffic. If the traffic is kept back at least 10 feet from the wall, the traffic surcharge may be neglected.
- 7.13.10 Seismic lateral forces will be required for any retaining walls in excess of 6 feet. Recommendations for seismic lateral forces will be provided under separate cover, if necessary.

7.14 Retaining Wall Drainage

- 7.14.1 Unless designed for hydrostatic pressures, retaining walls should be provided with a drainage system. At the base of the drain system, a subdrain covered with a minimum of 12 inches of gravel should be installed, and a compacted fill blanket or other seal placed at the surface (see Figure 17). The clean bottom and subdrain pipe, behind a retaining wall, should be observed by the Geotechnical Engineer (a representative of Geocon), prior to placement of gravel or compacting backfill.
- 7.14.2 As an alternative, a plastic drainage composite such as Miradrain or equivalent may be installed in continuous, 4-foot wide columns along the entire back face of the wall, at 8 feet on center. The top of these drainage composite columns should terminate approximately 18 inches below the ground surface, where either hardscape or a minimum of 18 inches of relatively cohesive material should be placed as a cap (see Figure 18). These vertical columns of drainage material would then be connected at the bottom of the wall to a 4-inch subdrain pipe.
- 7.14.3 Subdrainage pipes at the base of the retaining wall drainage system should outlet to an acceptable location via controlled drainage structures. Drainage should not be allowed to flow uncontrolled over descending slopes.
- 7.14.4 Moisture affecting below grade walls is one of the most common post-construction complaints. Poorly applied or omitted waterproofing can lead to efflorescence or standing water. Particular care should be taken in the design and installation of waterproofing to avoid moisture problems, or actual water seepage into the structure through any normal shrinkage cracks which may develop in the concrete walls, floor slab, foundations and/or construction joints. The design and inspection of the waterproofing is not the responsibility of the geotechnical engineer. A waterproofing consultant should be retained in order to recommend a product or method which would provide protection to subterranean walls, floor slabs and foundations.

7.15 Elevator Pit Design

- 7.15.1 The elevator pit slab and retaining wall should be designed by the project structural engineer. Elevator pit walls may be designed in accordance with the recommendations in the *Mat Foundation Design* and *Retaining Wall Design* sections of this report (see Sections 7.6 and 7.13).
- 7.15.2 Additional active pressure should be added for a surcharge condition due to sloping ground, vehicular traffic or adjacent foundations and should be designed for each condition as the project progresses.
- 7.15.3 If retaining wall drainage is to be provided, the drainage system should be designed in accordance with the *Retaining Wall Drainage* section of this report (see Section 7.14).
- 7.15.4 Subdrainage pipes at the base of the retaining wall drainage system should outlet to a location acceptable to the building official.
- 7.15.5 It is suggested that the exterior walls and slab be waterproofed to prevent excessive moisture inside of the elevator pit. Waterproofing design and installation is not the responsibility of the geotechnical engineer.

7.16 Elevator Piston

- 7.16.1 If a plunger-type elevator piston is installed for this project, a deep drilled excavation will be required. It is important to verify that the drilled excavation is not situated immediately adjacent to a foundation or shoring pile, or the drilled excavation could compromise the existing foundation support or pile support, especially if the drilling is performed subsequent to the foundation or pile construction.
- 7.16.2 Casing will be required since caving is expected in the drilled excavation, and the contractor should be prepared to use casing and should have it readily available at the commencement of drilling activities. Continuous observation of the drilling and installation of the elevator piston by the Geotechnical Engineer (a representative of Geocon West, Inc.) is required.
- 7.16.3 The annular space between the piston casing and drilled excavation wall should be filled with a minimum of 1½-sack slurry pumped from the bottom up. As an alternative, pea gravel may be utilized. The use of soil to backfill the annular space is not acceptable.

7.17 Temporary Excavations

- 7.17.1 Excavations up to 9 feet in height may be required during grading activities. The excavations are expected to expose artificial fill and alluvium, which are suitable for vertical excavations up to 5 feet in height where loose soils or caving sands are not present, and where not surcharged by adjacent traffic or structures.

- 7.17.2 Vertical excavations, greater than 5 feet or where surcharged by existing structures, will require sloping or shoring measures in order to provide a stable excavation. Where sufficient space is available, temporary unsurcharged embankments could be sloped back at a uniform 1:1 (H:V) slope gradient or flatter up to maximum height of 10 feet. A uniform slope does not have a vertical portion. Where space is limited, special excavation measures will be required.
- 7.17.3 If excavations in close proximity to an adjacent property line and/or structure are required, special excavation measures may be necessary in order to maintain lateral support of offsite improvements. If special excavation measures are required, the recommendations will be provided under separate cover.
- 7.17.4 Where temporary construction slopes are utilized, the top of the slope should be barricaded to prevent vehicles and storage loads at the top of the slope within a horizontal distance equal to the height of the slope. If the temporary construction slopes are to be maintained during the rainy season, berms are suggested along the tops of the slopes where necessary to prevent runoff water from entering the excavation and eroding the slope faces. Geocon personnel should inspect the soils exposed in the cut slopes during excavation so that modifications of the slopes can be made if variations in the soil conditions occur. All excavations should be stabilized within 30 days of initial excavation.

7.18 Stormwater Infiltration

- 7.18.1 During the December 1, 2022 site exploration, boring B2 was utilized to perform percolation testing. The boring was advanced to a depth of approximately 55 feet below the ground surface and then backfilled to the depth listed in the table below. Slotted casing was placed in the boring, and the annular space between the casing and excavation was filled with gravel. The boring was then filled with water to pre-saturate the soils. The casing was refilled with water, and percolation test readings were performed after repeated flooding of the cased excavation. Based on the test results, the measured infiltration rate and design infiltration rate, for the earth materials encountered, are provided in the following table. These values have been calculated in accordance with the Small Diameter Boring Infiltration Test Procedure in the County of Los Angeles Department of Public Works GMED *Guidelines for Geotechnical Investigation and Reporting, Low Impact Development Stormwater Infiltration* (June 2021). Percolation test field data and calculation of the measured infiltration rate and design infiltration rate are provided on Figure 19.

Boring	Soil Type	Infiltration Depth (ft)	Measured Infiltration Rate (in / hour)	Design Infiltration Rate (in / hour)
B2	SP	20– 30	10.62	3.54

- 7.18.2 Based on the test method utilized (Small Diameter Boring), the reduction factor RF_t may be taken as 1.0 in the infiltration system design. Based on the number of tests performed and consistency of the soils throughout the site, it is suggested that the reduction factor RF_v be taken as 1.0. In addition, provided proper maintenance is performed to minimize long-term siltation and plugging, the reduction factor RF_s may be taken as 1.0. Additional reduction factors may be required and should be applied by the engineer in responsible charge of the design of the stormwater infiltration system and based on applicable guidelines.
- 7.18.3 The results of the percolation testing indicate that the soils at depths in the above table are conducive to infiltration. It is our opinion that the soil zone encountered at the depth and location as listed in the table above are suitable for infiltration of stormwater.
- 7.18.4 It is our further opinion that infiltration of stormwater and will not induce excessive hydro-consolidation (see Figures B12 through B15), will not create a perched groundwater condition, will not affect soil structure interaction of existing or proposed foundations due to expansive soils, will not saturate soils supported by existing or proposed retaining walls, and will not increase the potential for liquefaction. Resulting settlements are anticipated to be less than $\frac{1}{4}$ inch, if any.
- 7.18.5 The infiltration system must be located such that the closest distance between an adjacent foundation is at least 15 feet in all directions from the zone of saturation. The zone of saturation may be assumed to project downward from the discharge of the infiltration facility at a gradient of 1:1. Additional property line or foundation setbacks may be required by the governing jurisdiction and should be incorporated into the stormwater infiltration system design as necessary.
- 7.18.6 Where the 15-foot horizontal setback cannot be maintained between the infiltration system and an adjacent footing, and the infiltration system penetrates below the foundation influence line, the proposed stormwater infiltration system must be designed to resist the surcharge from the adjacent foundation. The foundation surcharge line may be assumed to project down away from the bottom of the foundation at a 1:1 gradient. The stormwater infiltration system must still be sufficiently deep to maintain the 15-foot vertical offset between the bottom of the footing and the zone of saturation.
- 7.18.7 Subsequent to the placement of the infiltration system, it is acceptable to backfill the resulting void space between the excavation sidewalls and the infiltration system with minimum two-sack slurry provided the slurry is not placed in the infiltration zone. It is recommended that pea gravel be utilized adjacent to the infiltration zone so communication of water to the soil is not hindered.

7.18.8 Due to the preliminary nature of the project at this time, the type of stormwater infiltration system and location of the stormwater infiltration systems has not yet been determined. The design drawings should be reviewed and approved by the Geotechnical Engineer. The installation of the stormwater infiltration system should be observed and approved by the Geotechnical Engineer (a representative of Geocon).

7.19 Site Drainage and Moisture Protection

7.19.1 Proper surface drainage is critical to the future performance of the project. Uncontrolled infiltration of irrigation excess and storm runoff into the foundation supporting soils can adversely affect the performance of the planned improvements. Saturation of a soil can cause it to lose internal shear strength and increase its compressibility, resulting in a change in the original designed engineering properties. Proper drainage in building areas should be maintained at all times.

7.19.2 All site drainage should be collected and controlled in non-erosive drainage devices. Drainage should not be allowed to pond anywhere on the site, and especially not against any foundation or retaining wall. The site should be graded and maintained such that surface drainage is directed away from structures in accordance with 2022 CBC 1804.4 or other applicable standards. In addition, drainage should not be allowed to flow uncontrolled over any descending slope. Discharge from downspouts, roof drains and scuppers are not recommended onto unprotected soils within five feet of the building perimeter. Planters which are located adjacent to foundations should be sealed to prevent moisture intrusion into the soils providing foundation support. Landscape irrigation is not recommended within five feet of the building perimeter footings except when enclosed in protected planters.

7.19.3 Positive site drainage should be provided away from structures, pavement, and the tops of slopes to swales or other controlled drainage structures. The building pad and pavement areas should be fine graded such that water is not allowed to pond.

7.19.4 Landscaping planters immediately adjacent to paved areas are not recommended due to the potential for surface or irrigation water to infiltrate the pavement's subgrade and base course. Either a subdrain, which collects excess irrigation water and transmits it to drainage structures, or an impervious above-grade planter boxes should be used. In addition, where landscaping is planned adjacent to the pavement, it is recommended that consideration be given to providing a cutoff wall along the edge of the pavement that extends at least 12 inches below the base material.

7.20 Plan Review

- 7.20.1 Grading, foundation, and shoring plans should be reviewed by the Geotechnical Engineer prior to finalization to verify that the plans have been prepared in substantial conformance with the recommendations of this report and to provide additional analyses or recommendations, if necessary.

LIMITATIONS AND UNIFORMITY OF CONDITIONS

1. The recommendations of this report pertain only to the site investigated and are based upon the assumption that the soil conditions do not deviate from those disclosed in the investigation. If any variations or undesirable conditions are encountered during construction, or if the proposed construction will differ from that anticipated herein, Geocon West, Inc. should be notified so that supplemental recommendations can be given. The evaluation or identification of the potential presence of hazardous or corrosive materials was not part of the scope of services provided by Geocon West, Inc.
2. This report is issued with the understanding that it is the responsibility of the owner, or of his representative, to ensure that the information and recommendations contained herein are brought to the attention of the architect and engineer for the project and incorporated into the plans, and the necessary steps are taken to see that the contractor and subcontractors carry out such recommendations in the field.
3. The findings of this report are valid as of the date of this report. However, changes in the conditions of a property can occur with the passage of time, whether they are due to natural processes or the works of man on this or adjacent properties. In addition, changes in applicable or appropriate standards may occur, whether they result from legislation or the broadening of knowledge. Accordingly, the findings of this report may be invalidated wholly or partially by changes outside our control. Therefore, this report is subject to review and should not be relied upon after a period of three years.
4. The firm that performed the geotechnical investigation for the project should be retained to provide testing and observation services during construction to provide continuity of geotechnical interpretation and to check that the recommendations presented for geotechnical aspects of site development are incorporated during site grading, construction of improvements, and excavation of foundations. If another geotechnical firm is selected to perform the testing and observation services during construction operations, that firm should prepare a letter indicating their intent to assume the responsibilities of project geotechnical engineer of record. A copy of the letter should be provided to the regulatory agency for their records. In addition, that firm should provide revised recommendations concerning the geotechnical aspects of the proposed development, or a written acknowledgement of their concurrence with the recommendations presented in our report. They should also perform additional analyses deemed necessary to assume the role of Geotechnical Engineer of Record.

LIST OF REFERENCES

- Burbank, City of, 2013, *Burbank 2035 General Plan*.
- California Division of Mines and Geology, 1999; *State of California Seismic Hazard Zones, Burbank Quadrangle*, Official Map, Released: March 25, 1999.
- California Division of Mines and Geology, 1998, *Seismic Hazard Evaluation of the Burbank 7.5-Minute Quadrangle, Los Angeles County, California*, Open File Report 98-07.
- California Division of Mines and Geology, 1979, *State of California Special Studies Zones, Burbank Quadrangle, Official Map*, Effective: January 1, 1979.
- California Geologic Energy Management Division, 2022, Geologic Energy Management Division Resources Well Finder, <http://maps.conservation.ca.gov/doggr/index.html#close>.
- California Geological Survey, 2022a, CGS Information Warehouse, Regulatory Map Portal, <http://maps.conservation.ca.gov/cgs/informationwarehouse/index.html?map=regulatorymaps>.
- California Geological Survey, 2022b, Earthquake Zones of Required Investigation, <https://maps.conservation.ca.gov/cgs/EQZApp/app/>.
- California Geological Survey, 2018, *Earthquake Fault Zones, A Guide for Government Agencies, Property Owners/Developers, and Geoscience Practitioners for Assessing Fault Rupture Hazards in California*, Special Publication 42, Revised 2018.
- California Geological Survey, 2012, *Geologic Compilation of Quaternary Surficial Deposits in Southern California, Los Angeles 30' X 60' Quadrangle, A Project for the Department of Water Resources by the California Geological Survey*, Compiled from existing sources by Trinda L. Bedrossian, CEG and Peter D. Roffers, CGS Special Report 217, Plate 9, Scale 1:100,000.
- Dibblee, T. W., Jr., 1991, *Geologic Map of the Hollywood and Burbank (South ½) Quadrangles, Los Angeles County, California*, Dibblee Foundation Map # DF-30.
- FEMA, 2022, Online Flood Hazard Maps, <http://www.esri.com/hazards/index.html>.
- Jennings, C. W. and Bryant, W. A., 2010, *Fault Activity Map of California*, California Geological Survey Geologic Data Map No. 6.
- Hitchcock, C. S. and Wells, C. J., 2000, *Quaternary Geology of the San Fernando Valley, Los Angeles, California*, California Division of Mines and Geology Map Sheet 50.
- Leighton and Associates, Inc., 1990, *Technical Appendix to the Safety Element of the Los Angeles County General Plan, Hazard Reduction in Los Angeles County*.
- Los Angeles County, Department of Public Works (LACDPW), 2022a, Ground Water Wells Website, <http://dpw.lacounty.gov/general/wells>.
- Los Angeles County Department of Public Works (LACDPW), 2022b, Flood Zone Determination Website, <http://pw.lacounty.gov/floodzone>.

LIST OF REFERENCES (Continued)

- Topozada, T., Branum, D., Petersen, M., Hallstrom, C., and Reichle, M., 2000, *Epicenters and Areas Damaged by $M > 5$ California Earthquakes, 1800 – 1999*, California Geological Survey, Map Sheet 49.
- U.S. Geological Survey, 2022, Areas of Land Subsidence in California Website, https://ca.water.usgs.gov/land_subsidence/california-subsidence-areas.html
- U.S. Geological Survey and California Geological Survey, 2006, *Quaternary Fault and Fold Database for the United States*, USGS web site: <http://earthquake.usgs.gov/hazards/qfaults/>.
- U.S. Geological Survey, 1972, *Burbank 7.5-Minute Topographic Map*.
- Upper Los Angeles River Area Watermaster, 2017, *Annual Report, Watermaster Service in the Upper Los Angeles River Area (ULARA), Los Angeles County, California, 2015-16 Water Year, October 1, 2015 – September 30, 2016*, dated December 2017.
- Ziony, J. I., and Jones, L. M., 1989, *Map Showing Late Quaternary Faults and 1978–1984 Seismicity of the Los Angeles Region, California*, U.S. Geological Survey Miscellaneous Field Studies Map MF-1964.

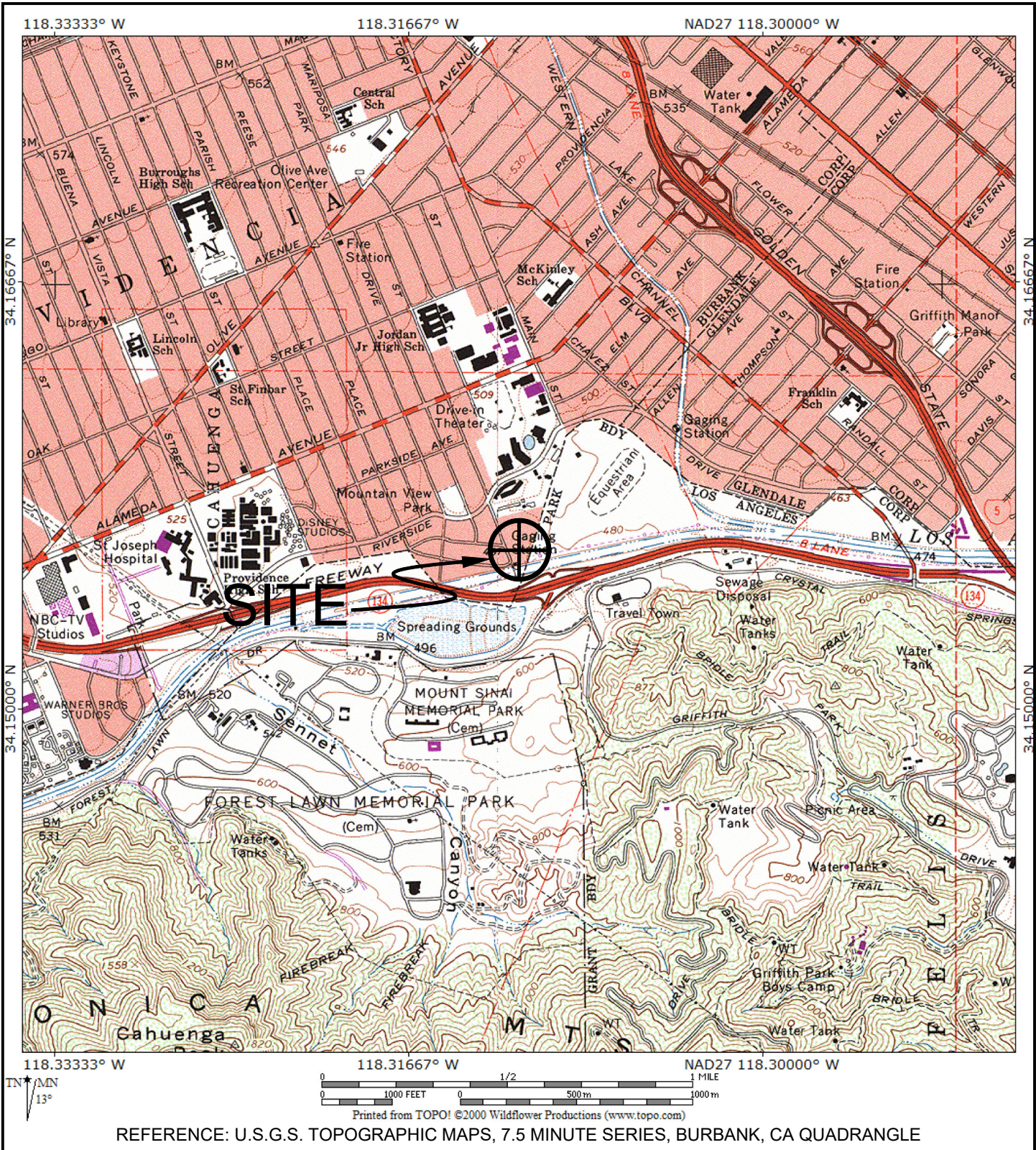

GEOCON
WEST, INC.



ENVIRONMENTAL GEOTECHNICAL MATERIALS
3303 N. SAN FERNANDO BLVD. - SUITE 100 - BURBANK, CA 91504
PHONE (818) 841-8388 - FAX (818) 841-1704

DRAFTED BY: RA	CHECKED BY: SFK
----------------	-----------------



VICINITY MAP

910 SOUTH MARIPOSA STREET
BURBANK, CALIFORNIA

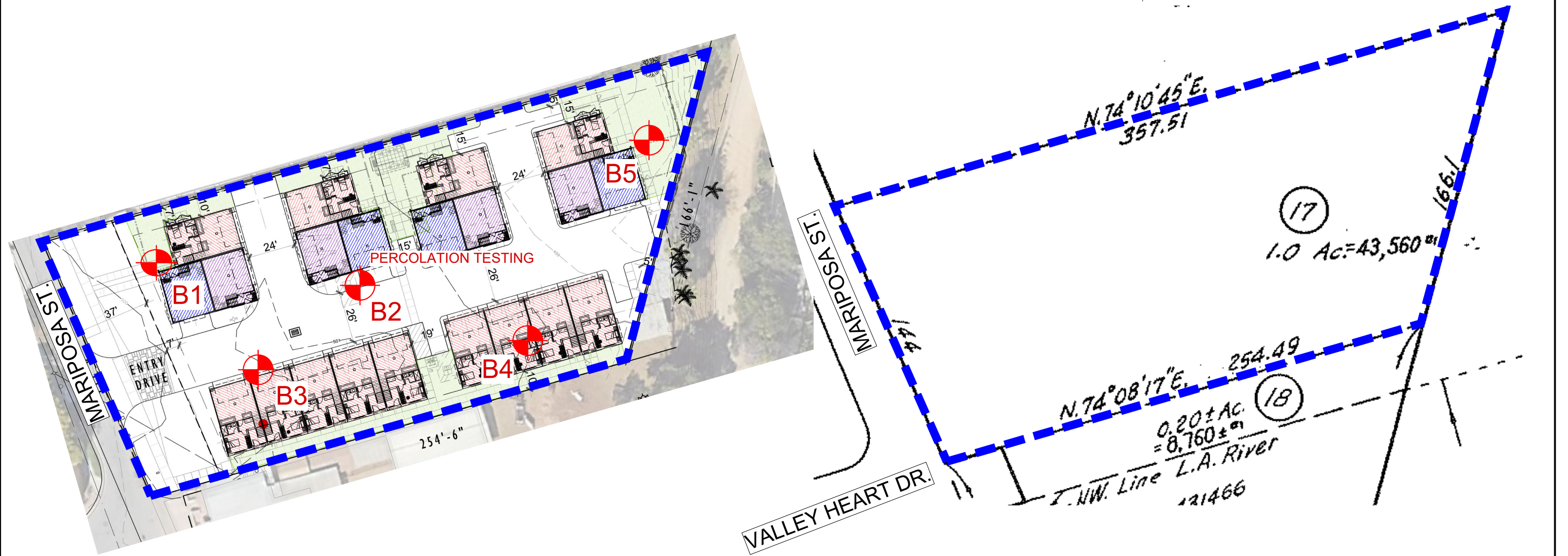
JAN. 2023	PROJECT NO. W1696-06-01	FIG. 1
-----------	-------------------------	--------



Legend

-  B5 Boring Locations
-  Limit of Proposed Improvements



GEOCON
WEST, INC.



ENVIRONMENTAL GEOTECHNICAL MATERIALS
3303 N. SAN FERNANDO BLVD. - SUITE 100 - BURBANK, CA 91504
PHONE (818) 841-8388 - FAX (818) 841-1704

DRAFTED BY: JJK

CHECKED BY: HDD

SITE PLAN

910 SOUTH MARIPOSA STREET
BURBANK, CALIFORNIA

JAN. 2023

PROJECT NO: W1696-06-01

FIG. 2

Reference: Jennings, C.W. and Bryant, W. A., 2010, Fault Activity Map of California, California Geological Survey Geologic Data Map No. 6.

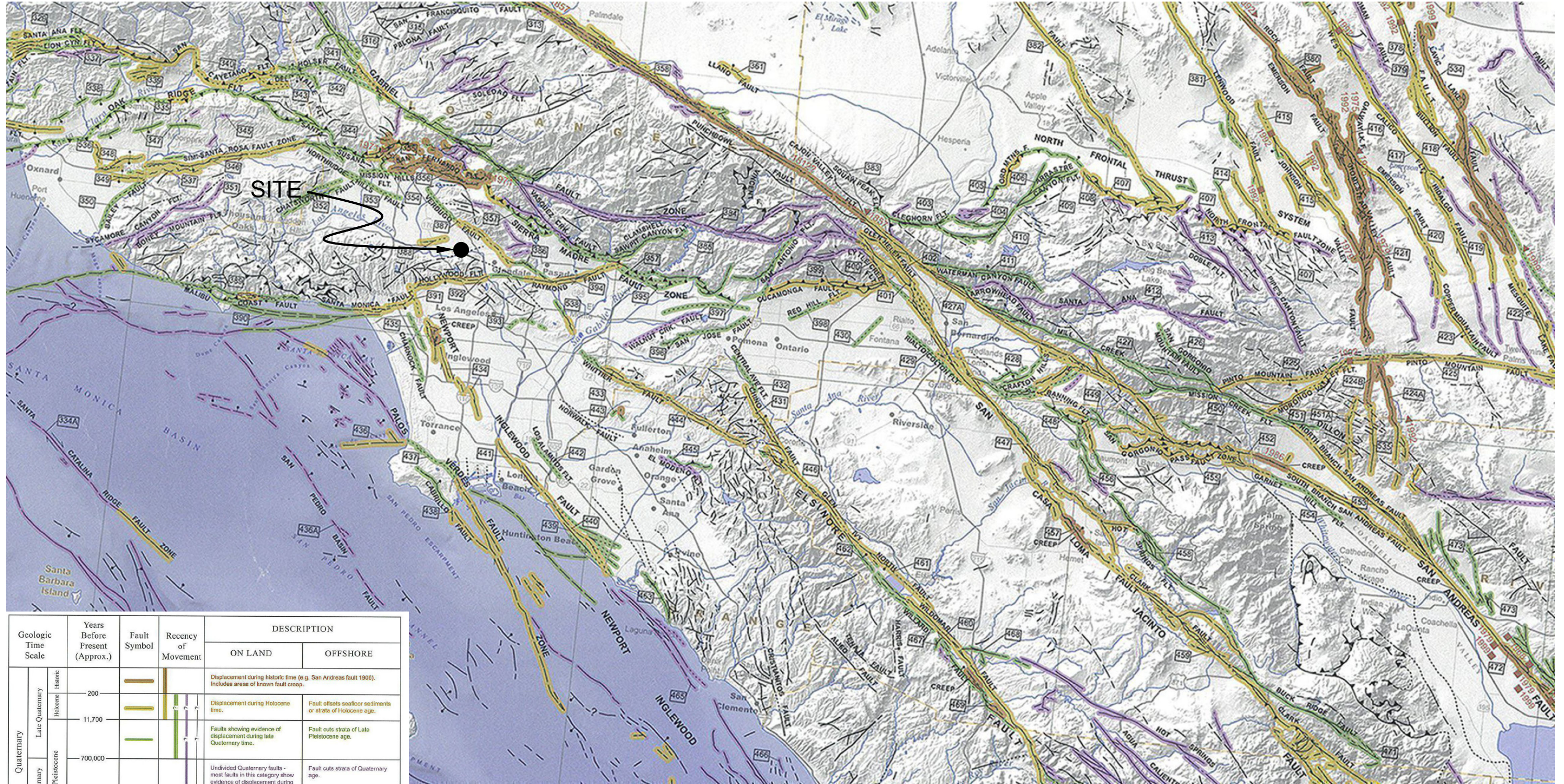

Geologic Time Scale	Years Before Present (Approx.)	Fault Symbol	Recency of Movement	DESCRIPTION	
				ON LAND	OFFSHORE
Quaternary	Recent (Holocene)			Displacement during historic time (e.g. San Andreas fault 1906). Includes areas of known fault creep.	
	Late Quaternary (Holocene)			Displacement during Holocene time.	Fault offsets surficial sediments or strata of Holocene age.
	Early Quaternary (Pleistocene)			Faults showing evidence of displacement during late Quaternary time.	Fault cuts strata of Late Pleistocene age.
Pre-Quaternary	1,600,000			Undivided Quaternary faults - most faults in this category show evidence of displacement during the last 1,600,000 years; possible exceptions are faults which displace rocks of undifferentiated Plio-Pleistocene age.	Fault cuts strata of Quaternary age.
	4.5 billion (Age of Earth)			Faults without recognized Quaternary displacement or showing evidence of no displacement during Quaternary time. Not necessarily inactive.	Fault cuts strata of Pliocene or older age.

* Quaternary now recognized as extending to 2.6 Ma (Walker and Geissman, 2009). Quaternary faults in this map were established using the previous 1.6 Ma criterion.

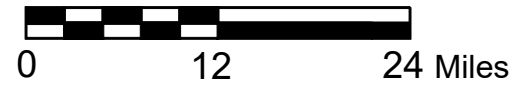

GEOCON WEST, INC.

ENVIRONMENTAL GEOTECHNICAL MATERIALS
 3303 N. SAN FERNANDO BLVD. - SUITE 100 - BURBANK, CA 91504
 PHONE (818) 841-8388 - FAX (818) 841-1704

REGIONAL FAULT MAP

910 SOUTH MARIPOSA STREET
 BURBANK, CALIFORNIA

JAN. 2023 PROJECT NO. W1696-06-01 FIG. 3

DRAFTED BY: RA CHECKED BY: SFK

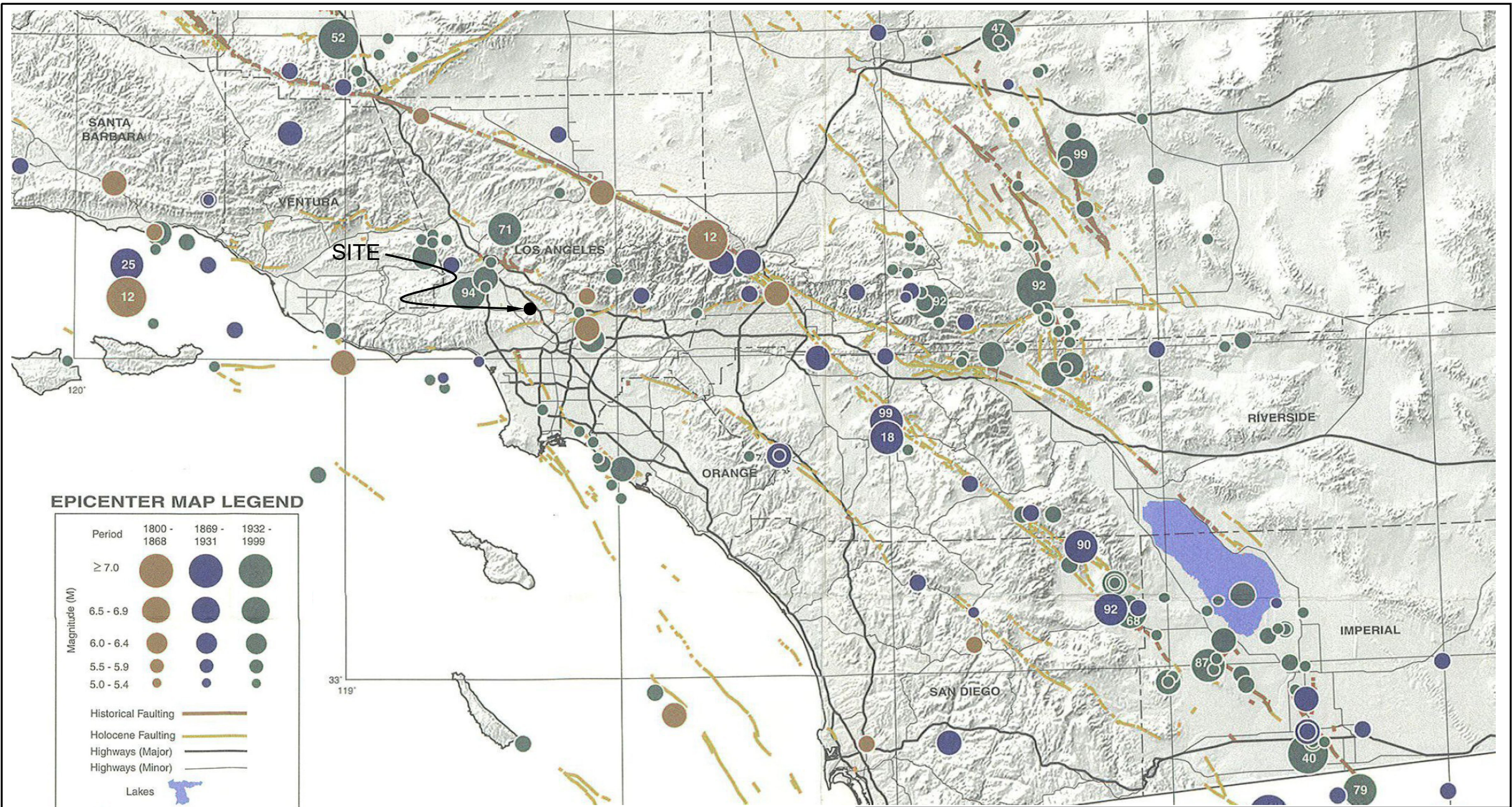

EPICENTER MAP LEGEND

Period	1800 - 1868	1869 - 1931	1932 - 1999
Magnitude (M)			
≥ 7.0			
6.5 - 6.9			
6.0 - 6.4			
5.5 - 5.9			
5.0 - 5.4			
Historical Faulting			
Holocene Faulting			
Highways (Major)			
Highways (Minor)			
Lakes			
	Last two digits of M ≥ 6.5 earthquake year		

Reference: Topozada, T., Branum, D., Petersen, M., Hallstrom, C., Cramer, C., and Reichle, M., 2000, Epicenters and Areas Damaged by M≥5 California Earthquakes, 1800 - 1999, California Geological Survey, Map Sheet 49.

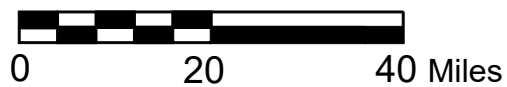

GEOCON
WEST, INC.



ENVIRONMENTAL GEOTECHNICAL MATERIALS
3303 N. SAN FERNANDO BLVD. - SUITE 100 - BURBANK, CA 91504
PHONE (818) 841-8388 - FAX (818) 841-1704

DRAFTED BY: RA

CHECKED BY: SFK

REGIONAL SEISMICITY MAP

910 SOUTH MARIPOSA STREET
BURBANK, CALIFORNIA

JAN. 2023

PROJECT NO. W1696-06-01

FIG.4



EMPIRICAL ESTIMATION OF LIQUEFACTION POTENTIAL DESIGN EARTHQUAKE

NCEER (1996) METHOD W 2001 UPDATES

EARTHQUAKE INFORMATION:

Earthquake Magnitude:	6.81
Peak Horiz. Acceleration PGA_M (g):	0.983
2/3 PGA_M (g):	0.656
Magnitude Scaling Factor:	1.280
Historic High Groundwater:	20.0
Groundwater Depth During Exploration:	100.0

ENERGY & ROD CORRECTIONS:

Energy Correction (CE) for N60:	1.25
Rod Len.Corr.(CR) (0-no or 1-yes):	1
Bore Dia. Corr. (CB):	1.00
Sampler Corr. (CS):	1.20
Use Ksigma (0-no or 1-yes):	1

LIQUEFACTION CALCULATIONS:

Unit Wt. Water (pcf):		62.4													
Depth to Base (ft)	Total Unit Wt. (pcf)	Water (0 or 1)	FIELD SPT (N)	Depth of SPT (ft)	Liq.Sus. (0 or 1)	-200 (%)	Est. Dr (%)	CN Factor	Corrected (N1)60	Eff. Unit Wt. (psf)	Resist. CRR 7.5	rd Factor	Induced CSR	Liquefac. Safe.Fact.	
1.0	93.4	0	4.0	5.0	1	63	45	1.700	14.2	93.4	0.152	1.000	0.426	--	
2.0	93.4	0	4.0	5.0	1	63	45	1.700	14.2	93.4	0.152	0.998	0.426	--	
3.0	93.4	0	4.0	5.0	1	63	45	1.700	14.2	93.4	0.152	0.996	0.425	--	
4.0	100.1	0	4.0	5.0	1	63	45	1.700	14.2	100.1	0.152	0.994	0.424	--	
5.0	100.1	0	4.0	5.0	1	63	45	1.700	14.2	100.1	0.152	0.991	0.423	--	
6.0	100.1	0	4.0	5.0	1	63	45	1.700	14.2	100.1	0.152	0.989	0.422	--	
7.0	100.1	0	4.0	5.0	1	63	45	1.700	14.2	100.1	0.152	0.987	0.421	--	
8.0	100.1	0	4.0	5.0	1	63	45	1.690	14.1	100.1	0.151	0.985	0.420	--	
9.0	100.1	0	9.0	10.0	1	19	61	1.585	20.7	100.1	0.224	0.982	0.419	--	
10.0	100.1	0	9.0	10.0	1	19	61	1.498	19.7	100.1	0.212	0.980	0.418	--	
11.0	100.1	0	9.0	10.0	1	19	61	1.423	18.9	100.1	0.202	0.978	0.417	--	
12.0	100.1	0	9.0	10.0	1	19	61	1.359	18.2	100.1	0.194	0.976	0.416	--	
13.0	99.6	0	15.4	12.5	1	55	76	1.302	32.1	99.6	Infin.	0.974	0.415	--	
14.0	99.6	0	15.4	12.5	1	55	76	1.253	31.0	99.6	Infin.	0.972	0.414	--	
15.0	99.3	0	12.0	15.0	1	22	65	1.208	23.1	99.3	0.259	0.970	0.413	--	
16.0	99.3	0	12.0	15.0	1	22	65	1.168	22.5	99.3	0.249	0.967	0.412	--	
17.0	99.3	0	12.0	15.0	1	22	65	1.132	21.9	99.3	0.241	0.965	0.411	--	
18.5	99.3	0	12.0	15.0	1	22	65	1.091	21.2	99.3	0.232	0.962	0.410	--	
19.0	99.3	0	10.0	20.0	1	9	56	1.076	15.3	99.3	0.163	0.960	0.409	--	
20.0	99.3	1	10.0	20.0	1	9	56	1.041	14.8	36.9	0.158	0.958	0.415	0.49	
21.0	99.3	1	10.0	20.0	1	9	56	1.015	14.4	36.9	0.154	0.956	0.427	0.46	
22.0	99.3	1	10.0	20.0	1	9	56	0.991	14.1	36.9	0.151	0.953	0.438	0.44	
23.0	115.2	1	32.5	22.5	1	5	99	0.967	43.7	52.8	Infin.	0.950	0.449	Non-Liq.	
24.0	115.2	1	32.5	22.5	1	5	99	0.943	42.6	52.8	Infin.	0.947	0.458	Non-Liq.	
25.0	115.2	1	25.0	25.0	1	5	86	0.921	33.0	52.8	Infin.	0.944	0.467	Non-Liq.	
26.0	115.2	1	25.0	25.0	1	5	86	0.900	32.2	52.8	Infin.	0.940	0.475	Non-Liq.	
27.0	121.2	1	55.0	27.5	1	5	125	0.880	71.1	58.8	Infin.	0.936	0.483	Non-Liq.	
28.0	121.2	1	55.0	27.5	1	5	125	0.861	69.5	58.8	Infin.	0.932	0.489	Non-Liq.	
29.0	121.2	1	55.0	27.5	1	5	125	0.843	68.1	58.8	Infin.	0.928	0.495	Non-Liq.	
30.0	121.2	1	55.0	27.5	1	5	125	0.826	66.7	58.8	Infin.	0.923	0.501	Non-Liq.	
31.0	118.6	1	100.0	30.0	1	5	166	0.810	121.6	56.2	Infin.	0.918	0.505	Non-Liq.	
32.0	118.6	1	100.0	30.0	1	5	166	0.796	119.3	56.2	Infin.	0.912	0.509	Non-Liq.	
33.0	118.6	1	100.0	30.0	1	5	166	0.782	117.3	56.2	Infin.	0.907	0.513	Non-Liq.	
34.0	118.6	1	100.0	30.0	1	5	166	0.769	115.3	56.2	Infin.	0.900	0.516	Non-Liq.	
35.0	118.6	1	100.0	30.0	1	5	166	0.756	113.4	56.2	Infin.	0.894	0.518	Non-Liq.	
36.0	118.6	1	100.0	35.0	1	5	161	0.744	111.6	56.2	Infin.	0.887	0.520	Non-Liq.	
37.0	118.6	1	100.0	35.0	1	5	161	0.733	109.9	56.2	Infin.	0.880	0.521	Non-Liq.	
38.0	118.6	1	100.0	35.0	1	5	161	0.722	108.2	56.2	Infin.	0.872	0.522	Non-Liq.	
39.0	104.0	1	100.0	35.0	1	5	161	0.712	106.8	41.6	Infin.	0.864	0.522	Non-Liq.	
40.0	104.0	1	100.0	35.0	1	5	161	0.703	105.4	41.6	Infin.	0.855	0.523	Non-Liq.	
41.0	104.0	1	100.0	40.0	1	5	156	0.694	104.2	41.6	Infin.	0.846	0.523	Non-Liq.	
42.0	104.0	1	100.0	40.0	1	5	156	0.686	102.9	41.6	Infin.	0.837	0.522	Non-Liq.	
43.0	104.0	1	100.0	40.0	1	5	156	0.678	101.8	41.6	Infin.	0.828	0.521	Non-Liq.	
44.0	104.0	1	100.0	40.0	1	5	156	0.671	100.6	41.6	Infin.	0.818	0.520	Non-Liq.	
45.0	104.0	1	100.0	40.0	1	5	156	0.663	99.5	41.6	Infin.	0.808	0.518	Non-Liq.	
46.0	104.0	1	100.0	45.0	1	5	153	0.656	98.4	41.6	Infin.	0.798	0.516	Non-Liq.	
47.0	104.0	1	100.0	45.0	1	5	153	0.649	97.4	41.6	Infin.	0.788	0.514	Non-Liq.	
48.0	104.0	1	100.0	45.0	1	5	153	0.643	96.4	41.6	Infin.	0.778	0.511	Non-Liq.	
49.0	104.0	1	100.0	45.0	1	5	153	0.636	95.4	41.6	Infin.	0.768	0.509	Non-Liq.	
50.0	104.0	1	100.0	45.0	1	5	153	0.630	94.5	41.6	Infin.	0.757	0.506	Non-Liq.	

Figure 5



Project Name : 910 S Mariposa
 Project No : W1696-06-01
 Boring : B1

LIQUEFACTION SETTLEMENT ANALYSIS DESIGN EARTHQUAKE

NCEER (1996) METHOD W 2001 UPDATES
 EARTHQUAKE INFORMATION:

Earthquake Magnitude:	6.81
PGA _M (g):	0.983
2/3 PGA _M (g):	0.66
Magnitude Scaling Factor:	1.280
Historic High Groundwater:	20.0
Groundwater @ Exploration:	100.0

DEPTH TO BASE	BLOW COUNT N	WET DENSITY (PCF)	TOTAL STRESS O (TSF)	EFFECT STRESS O' (TSF)	REL. DEN. Dr (%)	ADJUST BLOWS (N1)60	Tav/σ' _o	LIQUEFACTION SAFETY FACTOR	VOL. STRAIN [e _{1s}] (%)	EQ. SETTLE. Pe (in.)
1.0	4	93.4	0.023	0.023	45	14	0.426	--	0.00	0.00
2.0	4	93.4	0.070	0.070	45	14	0.426	--	0.00	0.00
3.0	4	93.4	0.117	0.117	45	14	0.426	--	0.00	0.00
4.0	4	100.1	0.165	0.165	45	14	0.426	--	0.00	0.00
5.0	4	100.1	0.215	0.215	45	14	0.426	--	0.00	0.00
6.0	4	100.1	0.265	0.265	45	14	0.426	--	0.00	0.00
7.0	4	100.1	0.315	0.315	45	14	0.426	--	0.00	0.00
8.0	4	100.1	0.365	0.365	45	14	0.426	--	0.00	0.00
9.0	9	100.1	0.415	0.415	61	21	0.426	--	0.00	0.00
10.0	9	100.1	0.465	0.465	61	20	0.426	--	0.00	0.00
11.0	9	100.1	0.515	0.515	61	19	0.426	--	0.00	0.00
12.0	9	100.1	0.566	0.566	61	18	0.426	--	0.00	0.00
13.0	15	99.6	0.615	0.615	76	32	0.426	--	0.00	0.00
14.0	15	99.6	0.665	0.665	76	31	0.426	--	0.00	0.00
15.0	12	99.3	0.715	0.715	65	23	0.426	--	0.00	0.00
16.0	12	99.3	0.765	0.765	65	22	0.426	--	0.00	0.00
17.0	12	99.3	0.814	0.814	65	22	0.426	--	0.00	0.00
18.5	12	99.3	0.876	0.876	65	21	0.426	--	0.00	0.00
19.0	10	99.3	0.901	0.901	56	15	0.426	--	0.00	0.00
20.0	10	99.3	0.963	0.948	56	15	0.433	0.49	1.80	0.22
21.0	10	99.3	1.013	0.966	56	14	0.447	0.46	1.80	0.22
22.0	10	99.3	1.063	0.985	56	14	0.460	0.44	1.80	0.22
23.0	32	115.2	1.116	1.007	99	44	0.472	Non-Liq.	0.00	0.00
24.0	32	115.2	1.174	1.033	99	43	0.484	Non-Liq.	0.00	0.00
25.0	25	115.2	1.231	1.060	86	33	0.495	Non-Liq.	0.00	0.00
26.0	25	115.2	1.289	1.086	86	32	0.506	Non-Liq.	0.00	0.00
27.0	55	121.2	1.348	1.114	125	71	0.516	Non-Liq.	0.00	0.00
28.0	55	121.2	1.409	1.143	125	70	0.525	Non-Liq.	0.00	0.00
29.0	55	121.2	1.469	1.173	125	68	0.534	Non-Liq.	0.00	0.00
30.0	55	121.2	1.530	1.202	125	67	0.542	Non-Liq.	0.00	0.00
31.0	100	118.6	1.590	1.231	166	122	0.550	Non-Liq.	0.00	0.00
32.0	100	118.6	1.649	1.259	166	119	0.558	Non-Liq.	0.00	0.00
33.0	100	118.6	1.708	1.287	166	117	0.566	Non-Liq.	0.00	0.00
34.0	100	118.6	1.768	1.315	166	115	0.573	Non-Liq.	0.00	0.00
35.0	100	118.6	1.827	1.343	166	113	0.580	Non-Liq.	0.00	0.00
36.0	100	118.6	1.886	1.372	161	112	0.586	Non-Liq.	0.00	0.00
37.0	100	118.6	1.946	1.400	161	110	0.592	Non-Liq.	0.00	0.00
38.0	100	118.6	2.005	1.428	161	108	0.598	Non-Liq.	0.00	0.00
39.0	100	104.0	2.061	1.452	161	107	0.605	Non-Liq.	0.00	0.00
40.0	100	104.0	2.113	1.473	161	105	0.611	Non-Liq.	0.00	0.00
41.0	100	104.0	2.165	1.494	156	104	0.618	Non-Liq.	0.00	0.00
42.0	100	104.0	2.217	1.515	156	103	0.624	Non-Liq.	0.00	0.00
43.0	100	104.0	2.269	1.535	156	102	0.630	Non-Liq.	0.00	0.00
44.0	100	104.0	2.321	1.556	156	101	0.636	Non-Liq.	0.00	0.00
45.0	100	104.0	2.373	1.577	156	100	0.641	Non-Liq.	0.00	0.00
46.0	100	104.0	2.425	1.598	153	98	0.647	Non-Liq.	0.00	0.00
47.0	100	104.0	2.477	1.619	153	97	0.652	Non-Liq.	0.00	0.00
48.0	100	104.0	2.529	1.639	153	96	0.657	Non-Liq.	0.00	0.00
49.0	100	104.0	2.581	1.660	153	95	0.662	Non-Liq.	0.00	0.00
50.0	100	104.0	2.633	1.681	153	94	0.667	Non-Liq.	0.00	0.00

TOTAL SETTLEMENT = 0.6 INCHES

Figure 6



EMPIRICAL ESTIMATION OF LIQUEFACTION POTENTIAL DESIGN EARTHQUAKE

NCEER (1996) METHOD W 2001 UPDATES

EARTHQUAKE INFORMATION:

Earthquake Magnitude:	6.81
Peak Horiz. Acceleration PGA_M (g):	0.983
2/3 PGA_M (g):	0.656
Magnitude Scaling Factor:	1.280
Historic High Groundwater:	20.0
Groundwater Depth During Exploration:	100.0

ENERGY & ROD CORRECTIONS:

Energy Correction (CE) for N60:	1.25
Rod Len.Corr.(CR) (0-no or 1-yes):	1
Bore Dia. Corr. (CB):	1.00
Sampler Corr. (CS):	1.20
Use Ksigma (0-no or 1-yes):	1

LIQUEFACTION CALCULATIONS:

Unit Wt. Water (pcf):		62.4														
Depth to Base (ft)	Total Unit Wt. (pcf)	Water (0 or 1)	FIELD SPT (N)	Depth of SPT (ft)	Liq.Sus. (0 or 1)	-200 (%)	Est. Dr (%)	CN Factor	Corrected (N1)60	Eff. Unit Wt. (psf)	Resist. CRR 7.5	rd Factor	Induced CSR	Liquefac. Safe.Fact.		
1.0	85.2	0	4.0	5.0	1	61	45	1.700	14.2	85.2	0.152	1.000	0.426	--		
2.0	85.2	0	4.0	5.0	1	61	45	1.700	14.2	85.2	0.152	0.998	0.426	--		
3.0	85.2	0	4.0	5.0	1	61	45	1.700	14.2	85.2	0.152	0.996	0.425	--		
4.0	85.2	0	4.0	5.0	1	61	45	1.700	14.2	85.2	0.152	0.994	0.424	--		
5.0	85.2	0	4.0	5.0	1	61	45	1.700	14.2	85.2	0.152	0.991	0.423	--		
6.0	85.2	0	4.0	5.0	1	61	45	1.700	14.2	85.2	0.152	0.989	0.422	--		
7.5	85.2	0	4.0	5.0	1	61	45	1.700	14.2	85.2	0.152	0.986	0.420	--		
8.0	85.2	0	4.0	5.0	1	61	45	1.700	14.2	85.2	0.152	0.984	0.419	--		
9.0	85.2	0	4.0	5.0	1	61	45	1.698	14.2	85.2	0.152	0.982	0.419	--		
10.0	79.4	0	7.0	10.0	1	6	55	1.609	12.8	79.4	0.138	0.980	0.418	--		
11.0	79.4	0	7.0	10.0	1	6	55	1.535	12.2	79.4	0.133	0.978	0.417	--		
12.0	96.4	0	9.0	12.0	1	73	60	1.464	22.8	96.4	0.254	0.976	0.416	--		
13.0	96.4	0	9.0	12.0	1	73	60	1.397	22.0	96.4	0.242	0.974	0.415	--		
14.0	96.4	0	9.0	12.0	1	73	60	1.338	21.3	96.4	0.232	0.972	0.414	--		
15.0	96.4	0	9.0	12.0	1	73	60	1.286	20.6	96.4	0.223	0.970	0.413	--		
16.0	96.4	0	2.0	17.5	1	65	26	1.239	8.8	96.4	0.103	0.967	0.412	--		
17.0	96.4	0	2.0	17.5	1	65	26	1.198	8.7	96.4	0.102	0.965	0.411	--		
18.0	96.4	0	2.0	17.5	1	30	26	1.160	8.1	96.4	0.097	0.963	0.410	--		
19.0	107.0	0	12.1	20.0	1	30	63	1.124	25.8	107.0	0.308	0.961	0.409	--		
20.0	107.0	1	12.1	20.0	1	30	63	1.089	25.1	44.6	0.294	0.958	0.416	0.91		
21.0	107.0	1	12.1	20.0	1	30	63	1.057	24.5	44.6	0.283	0.956	0.429	0.84		
22.0	114.1	1	24.0	22.5	1	5	87	1.027	34.3	51.7	Infin.	0.953	0.441	Non-Liq.		
23.0	114.1	1	24.0	22.5	1	5	87	0.999	33.4	51.7	Infin.	0.950	0.452	Non-Liq.		
24.0	114.1	1	24.0	22.5	1	5	87	0.973	32.5	51.7	Infin.	0.947	0.462	Non-Liq.		
25.0	114.1	1	24.0	22.5	1	5	87	0.949	31.7	51.7	Infin.	0.944	0.472	Non-Liq.		
26.0	114.1	1	55.0	25.0	1	5	129	0.926	73.0	51.7	Infin.	0.940	0.481	Non-Liq.		
27.0	114.1	1	55.0	25.0	1	5	129	0.905	71.3	51.7	Infin.	0.936	0.489	Non-Liq.		
28.0	114.1	1	49.0	27.5	1		120	0.885	63.7	51.7	Infin.	0.932	0.496	Non-Liq.		
29.0	114.1	1	49.0	27.5	1		120	0.867	62.4	51.7	Infin.	0.928	0.503	Non-Liq.		
30.0	114.1	1	49.0	27.5	1		120	0.850	61.2	51.7	Infin.	0.923	0.509	Non-Liq.		
31.0	120.7	1	49.0	27.5	1		120	0.833	60.0	58.3	Infin.	0.918	0.514	Non-Liq.		
32.0	120.7	1	49.0	27.5	1		120	0.817	58.8	58.3	Infin.	0.912	0.518	Non-Liq.		
33.0	120.7	1	31.0	32.5	1		92	0.802	37.3	58.3	Infin.	0.907	0.522	Non-Liq.		
34.0	120.7	1	31.0	32.5	1		92	0.787	36.6	58.3	Infin.	0.900	0.525	Non-Liq.		
35.0	120.7	1	31.0	32.5	1		92	0.773	36.0	58.3	Infin.	0.894	0.527	Non-Liq.		
36.0	120.7	1	31.0	32.5	1		92	0.760	35.4	58.3	Infin.	0.887	0.529	Non-Liq.		
37.0	120.7	1	31.0	32.5	1		92	0.748	34.8	58.3	Infin.	0.880	0.530	Non-Liq.		
38.0	105.2	1	41.0	37.5	1		103	0.737	45.3	42.8	Infin.	0.872	0.531	Non-Liq.		
39.0	105.2	1	41.0	37.5	1		103	0.727	44.7	42.8	Infin.	0.864	0.532	Non-Liq.		
40.0	105.2	1	41.0	37.5	1		103	0.717	44.1	42.8	Infin.	0.855	0.532	Non-Liq.		
41.0	105.2	1	41.0	37.5	1		103	0.708	43.6	42.8	Infin.	0.846	0.532	Non-Liq.		
42.0	105.2	1	41.0	37.5	1		103	0.700	43.0	42.8	Infin.	0.837	0.532	Non-Liq.		
43.0	109.5	1	64.0	42.5	1		126	0.691	66.3	47.1	Infin.	0.828	0.531	Non-Liq.		
44.0	109.5	1	64.0	42.5	1		126	0.682	65.5	47.1	Infin.	0.818	0.529	Non-Liq.		
45.0	109.5	1	64.0	42.5	1		126	0.674	64.7	47.1	Infin.	0.808	0.527	Non-Liq.		
46.0	109.5	1	64.0	42.5	1		126	0.666	64.0	47.1	Infin.	0.798	0.525	Non-Liq.		
47.0	109.5	1	64.0	42.5	1		126	0.659	63.2	47.1	Infin.	0.788	0.522	Non-Liq.		
48.0	132.6	1	100.0	47.5	1		153	0.651	97.6	70.2	Infin.	0.778	0.518	Non-Liq.		
49.0	132.6	1	100.0	47.5	1		153	0.642	96.3	70.2	Infin.	0.768	0.514	Non-Liq.		
50.0	132.6	1	100.0	47.5	1		153	0.634	95.1	70.2	Infin.	0.757	0.509	Non-Liq.		

Figure 7



Project Name : 910 S. Mariposa St
 Project No : W1696-06-01
 Boring : B2

LIQUEFACTION SETTLEMENT ANALYSIS DESIGN EARTHQUAKE

NCEER (1996) METHOD W 2001 UPDATES
 EARTHQUAKE INFORMATION:

Earthquake Magnitude:	6.81
PGA _M (g):	0.983
2/3 PGA _M (g):	0.66
Magnitude Scaling Factor:	1.280
Historic High Groundwater:	20.0
Groundwater @ Exploration:	100.0

DEPTH TO BASE	BLOW COUNT N	WET DENSITY (PCF)	TOTAL STRESS O (TSF)	EFFECT STRESS O' (TSF)	REL. DEN. Dr (%)	ADJUST BLOWS (N1)60	Tav/σ' _o	LIQUEFACTION SAFETY FACTOR	VOL. STRAIN [e _{1s}] (%)	EQ. SETTLE. Pe (in.)
1.0	4	85.2	0.021	0.021	45	14	0.426	--	0.00	0.00
2.0	4	85.2	0.064	0.064	45	14	0.426	--	0.00	0.00
3.0	4	85.2	0.107	0.107	45	14	0.426	--	0.00	0.00
4.0	4	85.2	0.149	0.149	45	14	0.426	--	0.00	0.00
5.0	4	85.2	0.192	0.192	45	14	0.426	--	0.00	0.00
6.0	4	85.2	0.234	0.234	45	14	0.426	--	0.00	0.00
7.5	4	85.2	0.288	0.288	45	14	0.426	--	0.00	0.00
8.0	4	85.2	0.309	0.309	45	14	0.426	--	0.00	0.00
9.0	4	85.2	0.362	0.362	45	14	0.426	--	0.00	0.00
10.0	7	79.4	0.403	0.403	55	13	0.426	--	0.00	0.00
11.0	7	79.4	0.443	0.443	55	12	0.426	--	0.00	0.00
12.0	9	96.4	0.487	0.487	60	23	0.426	--	0.00	0.00
13.0	9	96.4	0.535	0.535	60	22	0.426	--	0.00	0.00
14.0	9	96.4	0.583	0.583	60	21	0.426	--	0.00	0.00
15.0	9	96.4	0.632	0.632	60	21	0.426	--	0.00	0.00
16.0	2	96.4	0.680	0.680	26	9	0.426	--	0.00	0.00
17.0	2	96.4	0.728	0.728	26	9	0.426	--	0.00	0.00
18.0	2	96.4	0.776	0.776	26	8	0.426	--	0.00	0.00
19.0	12	107.0	0.827	0.827	63	26	0.426	--	0.00	0.00
20.0	12	107.0	0.880	0.865	63	25	0.434	0.91	1.00	0.12
21.0	12	107.0	0.934	0.887	63	25	0.449	0.84	1.30	0.16
22.0	24	114.1	0.989	0.911	87	34	0.463	Non-Liq.	0.00	0.00
23.0	24	114.1	1.046	0.937	87	33	0.476	Non-Liq.	0.00	0.00
24.0	24	114.1	1.103	0.963	87	32	0.488	Non-Liq.	0.00	0.00
25.0	24	114.1	1.160	0.989	87	32	0.500	Non-Liq.	0.00	0.00
26.0	55	114.1	1.217	1.015	129	73	0.511	Non-Liq.	0.00	0.00
27.0	55	114.1	1.274	1.040	129	71	0.522	Non-Liq.	0.00	0.00
28.0	49	114.1	1.332	1.066	120	64	0.532	Non-Liq.	0.00	0.00
29.0	49	114.1	1.389	1.092	120	62	0.542	Non-Liq.	0.00	0.00
30.0	49	114.1	1.446	1.118	120	61	0.551	Non-Liq.	0.00	0.00
31.0	49	120.7	1.504	1.146	120	60	0.560	Non-Liq.	0.00	0.00
32.0	49	120.7	1.565	1.175	120	59	0.568	Non-Liq.	0.00	0.00
33.0	31	120.7	1.625	1.204	92	37	0.575	Non-Liq.	0.00	0.00
34.0	31	120.7	1.685	1.233	92	37	0.583	Non-Liq.	0.00	0.00
35.0	31	120.7	1.746	1.262	92	36	0.589	Non-Liq.	0.00	0.00
36.0	31	120.7	1.806	1.291	92	35	0.596	Non-Liq.	0.00	0.00
37.0	31	120.7	1.866	1.320	92	35	0.602	Non-Liq.	0.00	0.00
38.0	41	105.2	1.923	1.346	103	45	0.609	Non-Liq.	0.00	0.00
39.0	41	105.2	1.976	1.367	103	45	0.616	Non-Liq.	0.00	0.00
40.0	41	105.2	2.028	1.389	103	44	0.622	Non-Liq.	0.00	0.00
41.0	41	105.2	2.081	1.410	103	44	0.629	Non-Liq.	0.00	0.00
42.0	41	105.2	2.133	1.431	103	43	0.635	Non-Liq.	0.00	0.00
43.0	64	109.5	2.187	1.454	126	66	0.641	Non-Liq.	0.00	0.00
44.0	64	109.5	2.242	1.477	126	66	0.647	Non-Liq.	0.00	0.00
45.0	64	109.5	2.296	1.501	126	65	0.652	Non-Liq.	0.00	0.00
46.0	64	109.5	2.351	1.524	126	64	0.657	Non-Liq.	0.00	0.00
47.0	64	109.5	2.406	1.548	126	63	0.662	Non-Liq.	0.00	0.00
48.0	100	132.6	2.467	1.577	153	98	0.666	Non-Liq.	0.00	0.00
49.0	100	132.6	2.533	1.612	153	96	0.669	Non-Liq.	0.00	0.00
50.0	100	132.6	2.599	1.648	153	95	0.672	Non-Liq.	0.00	0.00

TOTAL SETTLEMENT = 0.3 INCHES

Figure 8



EMPIRICAL ESTIMATION OF LIQUEFACTION POTENTIAL MAXIMUM CONSIDERED EARTHQUAKE

NCEER (1996) METHOD W 2001 UPDATES

EARTHQUAKE INFORMATION:

Earthquake Magnitude:	6.94
Peak Horiz. Acceleration PGA_M (g):	0.983
Magnitude Scaling Factor:	1.219
Historic High Groundwater:	20.0
Groundwater Depth During Exploration:	100.0

ENERGY & ROD CORRECTIONS:

Energy Correction (CE) for N60:	1.25
Rod Len.Corr.(CR) (0-no or 1-yes):	1
Bore Dia. Corr. (CB):	1.00
Sampler Corr. (CS):	1.20
Use Ksigma (0-no or 1-yes):	1

LIQUEFACTION CALCULATIONS:

Unit Wt. Water (pcf):																
62.4		Depth to Base (ft)	Total Unit Wt. (pcf)	Water (0 or 1)	Field SPT (N)	Depth of SPT (ft)	Liq.Sus. (0 or 1)	-200 (%)	Est. Dr (%)	CN Factor	Corrected (N1) _{60cs}	Eff. Unit Wt. (psf)	Resist. CRR 7.5	rd Factor	Induced CSR	Liquefac. Safe.Fact.
1.0	93.4	0	4.0	5.0	1	63	45	1.700	14.2	93.4	0.152	1.000	0.639	--		
2.0	93.4	0	4.0	5.0	1	63	45	1.700	14.2	93.4	0.152	0.998	0.638	--		
3.0	93.4	0	4.0	5.0	1	63	45	1.700	14.2	93.4	0.152	0.996	0.636	--		
4.0	100.1	0	4.0	5.0	1	63	45	1.700	14.2	100.1	0.152	0.994	0.635	--		
5.0	100.1	0	4.0	5.0	1	63	45	1.700	14.2	100.1	0.152	0.991	0.633	--		
6.0	100.1	0	4.0	5.0	1	63	45	1.700	14.2	100.1	0.152	0.989	0.632	--		
7.0	100.1	0	4.0	5.0	1	63	45	1.700	14.2	100.1	0.152	0.987	0.631	--		
8.0	100.1	0	4.0	5.0	1	63	45	1.690	14.1	100.1	0.151	0.985	0.629	--		
9.0	100.1	0	9.0	10.0	1	19	61	1.585	20.7	100.1	0.224	0.982	0.628	--		
10.0	100.1	0	9.0	10.0	1	19	61	1.498	19.7	100.1	0.212	0.980	0.626	--		
11.0	100.1	0	9.0	10.0	1	19	61	1.423	18.9	100.1	0.202	0.978	0.625	--		
12.0	100.1	0	9.0	10.0	1	19	61	1.359	18.2	100.1	0.194	0.976	0.624	--		
13.0	99.6	0	15.4	12.5	1	55	76	1.302	32.1	99.6	Inf.	0.974	0.622	--		
14.0	99.6	0	15.4	12.5	1	55	76	1.253	31.0	99.6	Inf.	0.972	0.621	--		
15.0	99.3	0	12.0	15.0	1	22	65	1.208	23.1	99.3	0.259	0.970	0.620	--		
16.0	99.3	0	12.0	15.0	1	22	65	1.168	22.5	99.3	0.249	0.967	0.618	--		
17.0	99.3	0	12.0	15.0	1	22	65	1.132	21.9	99.3	0.241	0.965	0.617	--		
18.5	99.3	0	12.0	15.0	1	22	65	1.091	21.2	99.3	0.232	0.962	0.615	--		
19.0	99.3	0	10.0	20.0	1	9	56	1.076	15.3	99.3	0.163	0.960	0.613	--		
20.0	99.3	1	10.0	20.0	1	9	56	1.041	14.8	36.9	0.158	0.958	0.622	0.31		
21.0	99.3	1	10.0	20.0	1	9	56	1.015	14.4	36.9	0.154	0.956	0.640	0.29		
22.0	99.3	1	10.0	20.0	1	9	56	0.991	14.1	36.9	0.151	0.953	0.657	0.28		
23.0	115.2	1	32.5	22.5	1	5	99	0.967	43.7	52.8	Inf.	0.950	0.673	Non-Liq.		
24.0	115.2	1	32.5	22.5	1	5	99	0.943	42.6	52.8	Inf.	0.947	0.687	Non-Liq.		
25.0	115.2	1	25.0	25.0	1	5	86	0.921	33.0	52.8	Inf.	0.944	0.700	Non-Liq.		
26.0	115.2	1	25.0	25.0	1	5	86	0.900	32.2	52.8	Inf.	0.940	0.713	Non-Liq.		
27.0	121.2	1	55.0	27.5	1	5	125	0.880	71.1	58.8	Inf.	0.936	0.724	Non-Liq.		
28.0	121.2	1	55.0	27.5	1	5	125	0.861	69.5	58.8	Inf.	0.932	0.734	Non-Liq.		
29.0	121.2	1	55.0	27.5	1	5	125	0.843	68.1	58.8	Inf.	0.928	0.743	Non-Liq.		
30.0	121.2	1	55.0	27.5	1	5	125	0.826	66.7	58.8	Inf.	0.923	0.750	Non-Liq.		
31.0	118.6	1	100.0	30.0	1	5	166	0.810	121.6	56.2	Inf.	0.918	0.757	Non-Liq.		
32.0	118.6	1	100.0	30.0	1	5	166	0.796	119.3	56.2	Inf.	0.912	0.764	Non-Liq.		
33.0	118.6	1	100.0	30.0	1	5	166	0.782	117.3	56.2	Inf.	0.907	0.769	Non-Liq.		
34.0	118.6	1	100.0	30.0	1	5	166	0.769	115.3	56.2	Inf.	0.900	0.773	Non-Liq.		
35.0	118.6	1	100.0	30.0	1	5	166	0.756	113.4	56.2	Inf.	0.894	0.777	Non-Liq.		
36.0	118.6	1	100.0	35.0	1	5	161	0.744	111.6	56.2	Inf.	0.887	0.779	Non-Liq.		
37.0	118.6	1	100.0	35.0	1	5	161	0.733	109.9	56.2	Inf.	0.880	0.781	Non-Liq.		
38.0	118.6	1	100.0	35.0	1	5	161	0.722	108.2	56.2	Inf.	0.872	0.782	Non-Liq.		
39.0	104.0	1	100.0	35.0	1	5	161	0.712	106.8	41.6	Inf.	0.864	0.783	Non-Liq.		
40.0	104.0	1	100.0	35.0	1	5	161	0.703	105.4	41.6	Inf.	0.855	0.784	Non-Liq.		
41.0	104.0	1	100.0	40.0	1	5	156	0.694	104.2	41.6	Inf.	0.846	0.784	Non-Liq.		
42.0	104.0	1	100.0	40.0	1	5	156	0.686	102.9	41.6	Inf.	0.837	0.783	Non-Liq.		
43.0	104.0	1	100.0	40.0	1	5	156	0.678	101.8	41.6	Inf.	0.828	0.782	Non-Liq.		
44.0	104.0	1	100.0	40.0	1	5	156	0.671	100.6	41.6	Inf.	0.818	0.780	Non-Liq.		
45.0	104.0	1	100.0	40.0	1	5	156	0.663	99.5	41.6	Inf.	0.808	0.777	Non-Liq.		
46.0	104.0	1	100.0	45.0	1	5	153	0.656	98.4	41.6	Inf.	0.798	0.774	Non-Liq.		
47.0	104.0	1	100.0	45.0	1	5	153	0.649	97.4	41.6	Inf.	0.788	0.771	Non-Liq.		
48.0	104.0	1	100.0	45.0	1	5	153	0.643	96.4	41.6	Inf.	0.778	0.767	Non-Liq.		
49.0	104.0	1	100.0	45.0	1	5	153	0.636	95.4	41.6	Inf.	0.768	0.762	Non-Liq.		
50.0	104.0	1	100.0	45.0	1	5	153	0.630	94.5	41.6	Inf.	0.757	0.758	Non-Liq.		
51.0	104.0	1	100.0	45.0	1	5	153	0.624	93.5	41.6	Inf.	0.747	0.753	Non-Liq.		
52.0	104.0	1	100.0	45.0	1	5	153	0.618	92.6	41.6	Inf.	0.737	0.748	Non-Liq.		
53.0	104.0	1	100.0	45.0	1	5	153	0.612	91.8	41.6	Inf.	0.727	0.743	Non-Liq.		
54.0	104.0	1	100.0	45.0	1	5	153	0.606	90.9	41.6	Inf.	0.717	0.738	Non-Liq.		
55.0	104.0	1	100.0	45.0	1	5	153	0.601	90.1	41.6	Inf.	0.708	0.733	Non-Liq.		
56.0	104.0	1	100.0	45.0	1	5	153	0.595	89.3	41.6	Inf.	0.698	0.728	Non-Liq.		
57.0	104.0	1	100.0	45.0	1	5	153	0.590	88.5	41.6	Inf.	0.689	0.722	Non-Liq.		
58.0	104.0	1	100.0	45.0	1	5	153	0.585	87.8	41.6	Inf.	0.680	0.717	Non-Liq.		
59.0	104.0	1	100.0	45.0	1	5	153	0.580	87.0	41.6	Inf.	0.671	0.712	Non-Liq.		
60.0	104.0	1	100.0	45.0	1	5	153	0.575	86.3	41.6	Inf.	0.663	0.707	Non-Liq.		
61.0	104.0	1	100.0	45.0	1	5	153	0.571	85.6	41.6	Inf.	0.655	0.702	Non-Liq.		
62.0	104.0	1	100.0	45.0	1	5	153	0.566	84.9	41.6	Inf.	0.647	0.697	Non-Liq.		
63.0	104.0	1	100.0	45.0	1	5	153	0.562	84.3	41.6	Inf.	0.639	0.693	Non-Liq.		
64.0	104.0	1	100.0	45.0	1	5	153	0.557	83.6	41.6	Inf.	0.632	0.688	Non-Liq.		
65.0	104.0	1	100.0	45.0	1	5	153	0.553	83.0	41.6	Inf.	0.625	0.684	Non-Liq.		
66.0	104.0	1	100.0	45.0	1	5	153	0.549	82.3	41.6	Inf.	0.618	0.680	Non-Liq.		
67.0	104.0	1	100.0	45.0	1	5	153	0.545	81.7	41.6	Inf.	0.612	0.676	Non-Liq.		
68.0	104.0	1	100.0	45.0	1	5	153	0.541	81.1	41.6	Inf.	0.606	0.672	Non-Liq.		
69.0	104.0	1	100.0	45.0	1	5	153	0.537	80.5	41.6	Inf.	0.600	0.669	Non-Liq.		
70.0	104.0	1	100.0	45.0	1	5	153	0.533	80.0	41.6	Inf.	0.594	0.665	Non-Liq.		

Figure 9



Project Name : 910 S Mariposa
 Project No : W1696-06-01
 Boring : B1

LIQUEFACTION SETTLEMENT ANALYSIS MAXIMUM CONSIDERED EARTHQUAKE

NCEER (1996) METHOD W 2001 UPDATES
 EARTHQUAKE INFORMATION:

Earthquake Magnitude:	6.94
PGA _M (g):	0.983
Magnitude Scaling Factor:	1.219
Historic High Groundwater:	20.0
Groundwater @ Exploration:	100.0

DEPTH TO BASE	BLOW COUNT N	WET DENSITY (PCF)	TOTAL STRESS O (TSF)	EFFECT STRESS O' (TSF)	REL. DEN. Dr (%)	ADJUST BLOWS (N1)60	Tav/σ' _o	LIQUEFACTION SAFETY FACTOR	VOL. STRAIN [e ₁₅] (%)	EQ. SETTLE. Pe (in.)
1.0	4	93.4	0.023	0.023	45	14	0.639	--	0.00	0.00
2.0	4	93.4	0.070	0.070	45	14	0.639	--	0.00	0.00
3.0	4	93.4	0.117	0.117	45	14	0.639	--	0.00	0.00
4.0	4	100.1	0.165	0.165	45	14	0.639	--	0.00	0.00
5.0	4	100.1	0.215	0.215	45	14	0.639	--	0.00	0.00
6.0	4	100.1	0.265	0.265	45	14	0.639	--	0.00	0.00
7.0	4	100.1	0.315	0.315	45	14	0.639	--	0.00	0.00
8.0	4	100.1	0.365	0.365	45	14	0.639	--	0.00	0.00
9.0	9	100.1	0.415	0.415	61	21	0.639	--	0.00	0.00
10.0	9	100.1	0.465	0.465	61	20	0.639	--	0.00	0.00
11.0	9	100.1	0.515	0.515	61	19	0.639	--	0.00	0.00
12.0	9	100.1	0.566	0.566	61	18	0.639	--	0.00	0.00
13.0	15	99.6	0.615	0.615	76	32	0.639	--	0.00	0.00
14.0	15	99.6	0.665	0.665	76	31	0.639	--	0.00	0.00
15.0	12	99.3	0.715	0.715	65	23	0.639	--	0.00	0.00
16.0	12	99.3	0.765	0.765	65	22	0.639	--	0.00	0.00
17.0	12	99.3	0.814	0.814	65	22	0.639	--	0.00	0.00
18.5	12	99.3	0.876	0.876	65	21	0.639	--	0.00	0.00
19.0	10	99.3	0.901	0.901	56	15	0.639	--	0.00	0.00
20.0	10	99.3	0.963	0.948	56	15	0.649	0.31	1.80	0.22
21.0	10	99.3	1.013	0.966	56	14	0.670	0.29	1.80	0.22
22.0	10	99.3	1.063	0.985	56	14	0.690	0.28	1.80	0.22
23.0	32	115.2	1.116	1.007	99	44	0.708	Non-Liq.	0.00	0.00
24.0	32	115.2	1.174	1.033	99	43	0.726	Non-Liq.	0.00	0.00
25.0	25	115.2	1.231	1.060	86	33	0.742	Non-Liq.	0.00	0.00
26.0	25	115.2	1.289	1.086	86	32	0.758	Non-Liq.	0.00	0.00
27.0	55	121.2	1.348	1.114	125	71	0.773	Non-Liq.	0.00	0.00
28.0	55	121.2	1.409	1.143	125	70	0.787	Non-Liq.	0.00	0.00
29.0	55	121.2	1.469	1.173	125	68	0.800	Non-Liq.	0.00	0.00
30.0	55	121.2	1.530	1.202	125	67	0.813	Non-Liq.	0.00	0.00
31.0	100	118.6	1.590	1.231	166	122	0.825	Non-Liq.	0.00	0.00
32.0	100	118.6	1.649	1.259	166	119	0.837	Non-Liq.	0.00	0.00
33.0	100	118.6	1.708	1.287	166	117	0.848	Non-Liq.	0.00	0.00
34.0	100	118.6	1.768	1.315	166	115	0.859	Non-Liq.	0.00	0.00
35.0	100	118.6	1.827	1.343	166	113	0.869	Non-Liq.	0.00	0.00
36.0	100	118.6	1.886	1.372	161	112	0.879	Non-Liq.	0.00	0.00
37.0	100	118.6	1.946	1.400	161	110	0.888	Non-Liq.	0.00	0.00
38.0	100	118.6	2.005	1.428	161	108	0.897	Non-Liq.	0.00	0.00
39.0	100	104.0	2.061	1.452	161	107	0.907	Non-Liq.	0.00	0.00
40.0	100	104.0	2.113	1.473	161	105	0.916	Non-Liq.	0.00	0.00
41.0	100	104.0	2.165	1.494	156	104	0.926	Non-Liq.	0.00	0.00
42.0	100	104.0	2.217	1.515	156	103	0.935	Non-Liq.	0.00	0.00
43.0	100	104.0	2.269	1.535	156	102	0.944	Non-Liq.	0.00	0.00
44.0	100	104.0	2.321	1.556	156	101	0.953	Non-Liq.	0.00	0.00
45.0	100	104.0	2.373	1.577	156	100	0.961	Non-Liq.	0.00	0.00
46.0	100	104.0	2.425	1.598	153	98	0.970	Non-Liq.	0.00	0.00
47.0	100	104.0	2.477	1.619	153	97	0.978	Non-Liq.	0.00	0.00
48.0	100	104.0	2.529	1.639	153	96	0.986	Non-Liq.	0.00	0.00
49.0	100	104.0	2.581	1.660	153	95	0.993	Non-Liq.	0.00	0.00
50.0	100	104.0	2.633	1.681	153	94	1.001	Non-Liq.	0.00	0.00

TOTAL SETTLEMENT = 0.6 INCHES

Figure 10



EMPIRICAL ESTIMATION OF LIQUEFACTION POTENTIAL MAXIMUM CONSIDERED EARTHQUAKE

NCEER (1996) METHOD W 2001 UPDATES

EARTHQUAKE INFORMATION:

Earthquake Magnitude:	6.94
Peak Horiz. Acceleration PGA_M (g):	0.983
Magnitude Scaling Factor:	1.219
Historic High Groundwater:	20.0
Groundwater Depth During Exploration:	100.0

ENERGY & ROD CORRECTIONS:

Energy Correction (CE) for N60:	1.25
Rod Len.Corr.(CR) (0-no or 1-yes):	1
Bore Dia. Corr. (CB):	1.00
Sampler Corr. (CS):	1.20
Use Ksigma (0-no or 1-yes):	1

LIQUEFACTION CALCULATIONS:

Unit Wt. Water (pcf):																
62.4		Depth to Base (ft)	Total Unit Wt. (pcf)	Water (0 or 1)	Field SPT (N)	Depth of SPT (ft)	Liq.Sus. (0 or 1)	-200 (%)	Est. Dr (%)	CN Factor	Corrected (N1) _{60cs}	Eff. Unit Wt. (psf)	Resist. CRR 7.5	rd Factor	Induced CSR	Liquefac. Safe.Fact.
1.0	85.2	0	4.0	5.0	1	61	45	1.700	14.2	85.2	0.152	1.000	0.639	--		
2.0	85.2	0	4.0	5.0	1	61	45	1.700	14.2	85.2	0.152	0.998	0.638	--		
3.0	85.2	0	4.0	5.0	1	61	45	1.700	14.2	85.2	0.152	0.996	0.636	--		
4.0	85.2	0	4.0	5.0	1	61	45	1.700	14.2	85.2	0.152	0.994	0.635	--		
5.0	85.2	0	4.0	5.0	1	61	45	1.700	14.2	85.2	0.152	0.991	0.633	--		
6.0	85.2	0	4.0	5.0	1	61	45	1.700	14.2	85.2	0.152	0.989	0.632	--		
7.5	85.2	0	4.0	5.0	1	61	45	1.700	14.2	85.2	0.152	0.986	0.630	--		
8.0	85.2	0	4.0	5.0	1	61	45	1.700	14.2	85.2	0.152	0.984	0.629	--		
9.0	85.2	0	4.0	5.0	1	61	45	1.698	14.2	85.2	0.152	0.982	0.628	--		
10.0	79.4	0	7.0	10.0	1	6	55	1.609	12.8	79.4	0.138	0.980	0.626	--		
11.0	79.4	0	7.0	10.0	1	6	55	1.535	12.2	79.4	0.133	0.978	0.625	--		
12.0	96.4	0	9.0	12.0	1	73	60	1.464	22.8	96.4	0.254	0.976	0.624	--		
13.0	96.4	0	9.0	12.0	1	73	60	1.397	22.0	96.4	0.242	0.974	0.622	--		
14.0	96.4	0	9.0	12.0	1	73	60	1.338	21.3	96.4	0.232	0.972	0.621	--		
15.0	96.4	0	9.0	12.0	1	73	60	1.286	20.6	96.4	0.223	0.970	0.620	--		
16.0	96.4	0	2.0	17.5	1	65	26	1.239	8.8	96.4	0.103	0.967	0.618	--		
17.0	96.4	0	2.0	17.5	1	65	26	1.198	8.7	96.4	0.102	0.965	0.617	--		
18.0	96.4	0	2.0	17.5	1	30	26	1.160	8.1	96.4	0.097	0.963	0.615	--		
19.0	107.0	0	12.1	20.0	1	30	63	1.124	25.8	107.0	0.308	0.961	0.614	--		
20.0	107.0	1	12.1	20.0	1	30	63	1.089	25.1	44.6	0.294	0.958	0.623	0.58		
21.0	107.0	1	12.1	20.0	1	30	63	1.057	24.5	44.6	0.283	0.956	0.643	0.54		
22.0	114.1	1	24.0	22.5	1	5	87	1.027	34.3	51.7	Inf.	0.953	0.661	Non-Liq.		
23.0	114.1	1	24.0	22.5	1	5	87	0.999	33.4	51.7	Inf.	0.950	0.678	Non-Liq.		
24.0	114.1	1	24.0	22.5	1	5	87	0.973	32.5	51.7	Inf.	0.947	0.693	Non-Liq.		
25.0	114.1	1	24.0	22.5	1	5	87	0.949	31.7	51.7	Inf.	0.944	0.707	Non-Liq.		
26.0	114.1	1	55.0	25.0	1	5	129	0.926	73.0	51.7	Inf.	0.940	0.721	Non-Liq.		
27.0	114.1	1	55.0	25.0	1	5	129	0.905	71.3	51.7	Inf.	0.936	0.733	Non-Liq.		
28.0	114.1	1	49.0	27.5	1	0	120	0.885	63.7	51.7	Inf.	0.932	0.744	Non-Liq.		
29.0	114.1	1	49.0	27.5	1	0	120	0.867	62.4	51.7	Inf.	0.928	0.754	Non-Liq.		
30.0	114.1	1	49.0	27.5	1	0	120	0.850	61.2	51.7	Inf.	0.923	0.763	Non-Liq.		
31.0	120.7	1	49.0	27.5	1	0	120	0.833	60.0	58.3	Inf.	0.918	0.770	Non-Liq.		
32.0	120.7	1	49.0	27.5	1	0	120	0.817	58.8	58.3	Inf.	0.912	0.777	Non-Liq.		
33.0	120.7	1	31.0	32.5	1	0	92	0.802	37.3	58.3	Inf.	0.907	0.782	Non-Liq.		
34.0	120.7	1	31.0	32.5	1	0	92	0.787	36.6	58.3	Inf.	0.900	0.786	Non-Liq.		
35.0	120.7	1	31.0	32.5	1	0	92	0.773	36.0	58.3	Inf.	0.894	0.790	Non-Liq.		
36.0	120.7	1	31.0	32.5	1	0	92	0.760	35.4	58.3	Inf.	0.887	0.793	Non-Liq.		
37.0	120.7	1	31.0	32.5	1	0	92	0.748	34.8	58.3	Inf.	0.880	0.794	Non-Liq.		
38.0	105.2	1	41.0	37.5	1	0	103	0.737	45.3	42.8	Inf.	0.872	0.796	Non-Liq.		
39.0	105.2	1	41.0	37.5	1	0	103	0.727	44.7	42.8	Inf.	0.864	0.797	Non-Liq.		
40.0	105.2	1	41.0	37.5	1	0	103	0.717	44.1	42.8	Inf.	0.855	0.798	Non-Liq.		
41.0	105.2	1	41.0	37.5	1	0	103	0.708	43.6	42.8	Inf.	0.846	0.798	Non-Liq.		
42.0	105.2	1	41.0	37.5	1	0	103	0.700	43.0	42.8	Inf.	0.837	0.797	Non-Liq.		
43.0	109.5	1	64.0	42.5	1	0	126	0.691	66.3	47.1	Inf.	0.828	0.796	Non-Liq.		
44.0	109.5	1	64.0	42.5	1	0	126	0.682	65.5	47.1	Inf.	0.818	0.793	Non-Liq.		
45.0	109.5	1	64.0	42.5	1	0	126	0.674	64.7	47.1	Inf.	0.808	0.790	Non-Liq.		
46.0	109.5	1	64.0	42.5	1	0	126	0.666	64.0	47.1	Inf.	0.798	0.787	Non-Liq.		
47.0	109.5	1	64.0	42.5	1	0	126	0.659	63.2	47.1	Inf.	0.788	0.783	Non-Liq.		
48.0	132.6	1	100.0	47.5	1	0	153	0.651	97.6	70.2	Inf.	0.778	0.777	Non-Liq.		
49.0	132.6	1	100.0	47.5	1	0	153	0.642	96.3	70.2	Inf.	0.768	0.771	Non-Liq.		
50.0	132.6	1	100.0	47.5	1	0	153	0.634	95.1	70.2	Inf.	0.757	0.764	Non-Liq.		
51.0	132.6	1	100.0	47.5	1	0	153	0.626	93.9	70.2	Inf.	0.747	0.756	Non-Liq.		
52.0	132.6	1	100.0	47.5	1	0	153	0.618	92.7	70.2	Inf.	0.737	0.749	Non-Liq.		
53.0	132.6	1	100.0	47.5	1	0	153	0.611	91.6	70.2	Inf.	0.727	0.742	Non-Liq.		
54.0	132.6	1	100.0	47.5	1	0	153	0.604	90.6	70.2	Inf.	0.717	0.734	Non-Liq.		
55.0	132.6	1	100.0	47.5	1	0	153	0.597	89.5	70.2	Inf.	0.708	0.727	Non-Liq.		
56.0	132.6	1	100.0	55.0	1	0	146	0.590	88.5	70.2	Inf.	0.698	0.720	Non-Liq.		
57.0	132.6	1	100.0	55.0	1	0	146	0.584	87.6	70.2	Inf.	0.689	0.712	Non-Liq.		
58.0	109.9	1	100.0	55.0	1	0	146	0.578	86.7	47.5	Inf.	0.680	0.706	Non-Liq.		
59.0	109.9	1	100.0	55.0	1	0	146	0.573	86.0	47.5	Inf.	0.671	0.701	Non-Liq.		
60.0	109.9	1	100.0	55.0	1	0	146	0.568	85.2	47.5	Inf.	0.663	0.695	Non-Liq.		
61.0	109.9	1	100.0	55.0	1	0	146	0.563	84.5	47.5	Inf.	0.655	0.690	Non-Liq.		
62.0	109.9	1	100.0	55.0	1	0	146	0.559	83.8	47.5	Inf.	0.647	0.685	Non-Liq.		
63.0	109.9	1	100.0	55.0	1	0	146	0.554	83.1	47.5	Inf.	0.639	0.680	Non-Liq.		
64.0	109.9	1	100.0	55.0	1	0	146	0.550	82.5	47.5	Inf.	0.632	0.676	Non-Liq.		
65.0	109.9	1	100.0	55.0	1	0	146	0.545	81.8	47.5	Inf.	0.625	0.671	Non-Liq.		
66.0	109.9	1	100.0	55.0	1	0	146	0.541	81.2	47.5	Inf.	0.618	0.667	Non-Liq.		
67.0	109.9	1	100.0	55.0	1	0	146	0.537	80.6	47.5	Inf.	0.612	0.662	Non-Liq.		
68.0	109.9	1	100.0	55.0	1	0	146	0.533	80.0	47.5	Inf.	0.606	0.658	Non-Liq.		
69.0	109.9	1	100.0	55.0	1	0	146	0.529	79.4	47.5	Inf.	0.600	0.655	Non-Liq.		
70.0	109.9	1	100.0	55.0	1	0	146	0.525	78.8	47.5	Inf.	0.594	0.651	Non-Liq.		

Figure 11



Project Name : 910 S. Mariposa St
 Project No : W1696-06-01
 Boring : B2

LIQUEFACTION SETTLEMENT ANALYSIS MAXIMUM CONSIDERED EARTHQUAKE

NCEER (1996) METHOD W 2001 UPDATES
 EARTHQUAKE INFORMATION:

Earthquake Magnitude:	6.94
PGA _M (g):	0.983
Magnitude Scaling Factor:	1.219
Historic High Groundwater:	20.0
Groundwater @ Exploration:	100.0

DEPTH TO BASE	BLOW COUNT N	WET DENSITY (PCF)	TOTAL STRESS O (TSF)	EFFECT STRESS O' (TSF)	REL. DEN. Dr (%)	ADJUST BLOWS (N1)60	Tav/σ' _o	LIQUEFACTION SAFETY FACTOR	VOL. STRAIN [e ₁₅] (%)	EQ. SETTLE. Pe (in.)
1.0	4	85.2	0.021	0.021	45	14	0.639	--	0.00	0.00
2.0	4	85.2	0.064	0.064	45	14	0.639	--	0.00	0.00
3.0	4	85.2	0.107	0.107	45	14	0.639	--	0.00	0.00
4.0	4	85.2	0.149	0.149	45	14	0.639	--	0.00	0.00
5.0	4	85.2	0.192	0.192	45	14	0.639	--	0.00	0.00
6.0	4	85.2	0.234	0.234	45	14	0.639	--	0.00	0.00
7.5	4	85.2	0.288	0.288	45	14	0.639	--	0.00	0.00
8.0	4	85.2	0.309	0.309	45	14	0.639	--	0.00	0.00
9.0	4	85.2	0.362	0.362	45	14	0.639	--	0.00	0.00
10.0	7	79.4	0.403	0.403	55	13	0.639	--	0.00	0.00
11.0	7	79.4	0.443	0.443	55	12	0.639	--	0.00	0.00
12.0	9	96.4	0.487	0.487	60	23	0.639	--	0.00	0.00
13.0	9	96.4	0.535	0.535	60	22	0.639	--	0.00	0.00
14.0	9	96.4	0.583	0.583	60	21	0.639	--	0.00	0.00
15.0	9	96.4	0.632	0.632	60	21	0.639	--	0.00	0.00
16.0	2	96.4	0.680	0.680	26	9	0.639	--	0.00	0.00
17.0	2	96.4	0.728	0.728	26	9	0.639	--	0.00	0.00
18.0	2	96.4	0.776	0.776	26	8	0.639	--	0.00	0.00
19.0	12	107.0	0.827	0.827	63	26	0.639	--	0.00	0.00
20.0	12	107.0	0.880	0.865	63	25	0.650	0.58	1.10	0.13
21.0	12	107.0	0.934	0.887	63	25	0.673	0.54	1.30	0.16
22.0	24	114.1	0.989	0.911	87	34	0.694	Non-Liq.	0.00	0.00
23.0	24	114.1	1.046	0.937	87	33	0.713	Non-Liq.	0.00	0.00
24.0	24	114.1	1.103	0.963	87	32	0.732	Non-Liq.	0.00	0.00
25.0	24	114.1	1.160	0.989	87	32	0.750	Non-Liq.	0.00	0.00
26.0	55	114.1	1.217	1.015	129	73	0.767	Non-Liq.	0.00	0.00
27.0	55	114.1	1.274	1.040	129	71	0.783	Non-Liq.	0.00	0.00
28.0	49	114.1	1.332	1.066	120	64	0.798	Non-Liq.	0.00	0.00
29.0	49	114.1	1.389	1.092	120	62	0.812	Non-Liq.	0.00	0.00
30.0	49	114.1	1.446	1.118	120	61	0.826	Non-Liq.	0.00	0.00
31.0	49	120.7	1.504	1.146	120	60	0.839	Non-Liq.	0.00	0.00
32.0	49	120.7	1.565	1.175	120	59	0.851	Non-Liq.	0.00	0.00
33.0	31	120.7	1.625	1.204	92	37	0.863	Non-Liq.	0.00	0.00
34.0	31	120.7	1.685	1.233	92	37	0.873	Non-Liq.	0.00	0.00
35.0	31	120.7	1.746	1.262	92	36	0.884	Non-Liq.	0.00	0.00
36.0	31	120.7	1.806	1.291	92	35	0.894	Non-Liq.	0.00	0.00
37.0	31	120.7	1.866	1.320	92	35	0.903	Non-Liq.	0.00	0.00
38.0	41	105.2	1.923	1.346	103	45	0.913	Non-Liq.	0.00	0.00
39.0	41	105.2	1.976	1.367	103	45	0.923	Non-Liq.	0.00	0.00
40.0	41	105.2	2.028	1.389	103	44	0.933	Non-Liq.	0.00	0.00
41.0	41	105.2	2.081	1.410	103	44	0.943	Non-Liq.	0.00	0.00
42.0	41	105.2	2.133	1.431	103	43	0.952	Non-Liq.	0.00	0.00
43.0	64	109.5	2.187	1.454	126	66	0.961	Non-Liq.	0.00	0.00
44.0	64	109.5	2.242	1.477	126	66	0.970	Non-Liq.	0.00	0.00
45.0	64	109.5	2.296	1.501	126	65	0.978	Non-Liq.	0.00	0.00
46.0	64	109.5	2.351	1.524	126	64	0.985	Non-Liq.	0.00	0.00
47.0	64	109.5	2.406	1.548	126	63	0.993	Non-Liq.	0.00	0.00
48.0	100	132.6	2.467	1.577	153	98	0.999	Non-Liq.	0.00	0.00
49.0	100	132.6	2.533	1.612	153	96	1.004	Non-Liq.	0.00	0.00
50.0	100	132.6	2.599	1.648	153	95	1.008	Non-Liq.	0.00	0.00

TOTAL SETTLEMENT = 0.3 INCHES

Figure 12

TECHNICAL ENGINEERING AND DESIGN GUIDES AS ADAPTED FROM THE US ARMY CORPS OF ENGINEERS, NO. 9 EVALUATION OF EARTHQUAKE-INDUCED SETTLEMENTS IN DRY SANDY SOILS DESIGN EARTHQUAKE

DE EARTHQUAKE INFORMATION:

Earthquake Magnitude:	6.81
Peak Horiz. Acceleration (g):	0.656

Fig 4.1 Fig 4.2

Fig 4.4

Depth of Base of Strata (ft)	Thickness of Layer (ft)	Depth of Mid-point of Layer (ft)	Soil Unit Weight (pcf)	Overburden Pressure at Mid-point (tsf)	Mean Effective Pressure at Mid-point (tsf)	Average Cyclic Shear Stress [Tav]	Field SPT [N]	Correction Factor [Ccr]	Relative Density [Dr] (%)	Correction Factor [Cn]	Corrected [N]60	rd Factor	Maximum Shear Mod. [Gmax] (tsf)	yeff /[Geff] [Gmax]	yeff Shear Strain	veff *100%	Volumetric Strain M7.5 [E15] (%)	Number of Strain Cycles [Nc]	Corrected Vol. Strains [Ec]	Estimated Settlement [S] (inches)
1.0	1.0	0.5	93.4	0.02	0.02	0.010	4	1.25	44.6	1.7	14.2	1.0	135.3	7.28E-05	1.40E-04	0.014	2.12E-02	9.4	1.72E-02	Grading
2.0	1.0	1.5	93.4	0.07	0.05	0.030	4	1.25	44.6	1.7	14.2	1.0	234.4	1.24E-04	2.30E-04	0.023	3.47E-02	9.4	2.82E-02	Grading
3.0	1.0	2.5	93.4	0.12	0.08	0.050	4	1.25	44.6	1.7	14.2	1.0	302.6	1.57E-04	2.30E-04	0.023	3.47E-02	9.4	2.82E-02	Grading
4.0	1.0	3.5	100.1	0.17	0.11	0.070	4	1.25	44.6	1.7	14.2	1.0	359.9	1.83E-04	1.70E-04	0.017	2.57E-02	9.4	2.08E-02	Grading
5.0	1.0	4.5	100.1	0.22	0.14	0.092	4	1.25	44.6	1.7	14.2	1.0	410.8	2.04E-04	8.10E-04	0.081	1.22E-01	9.4	9.92E-02	Grading
6.0	1.0	5.5	100.1	0.27	0.18	0.113	4	1.25	44.6	1.7	14.2	1.0	456.1	2.23E-04	8.10E-04	0.081	1.22E-01	9.4	9.92E-02	Grading
7.0	1.0	6.5	100.1	0.32	0.21	0.134	4	1.25	44.6	1.7	14.2	1.0	497.3	2.38E-04	4.50E-04	0.045	6.80E-02	9.4	5.51E-02	0.01
8.0	1.0	7.5	100.1	0.37	0.24	0.155	4	1.25	44.6	1.7	14.1	1.0	534.6	2.52E-04	4.50E-04	0.045	6.83E-02	9.4	5.54E-02	0.01
9.0	1.0	8.5	100.1	0.42	0.28	0.176	9	1.25	60.9	1.6	20.7	1.0	647.0	2.32E-04	4.50E-04	0.045	4.33E-02	9.4	3.51E-02	0.01
10.0	1.0	9.5	100.1	0.47	0.31	0.197	9	1.25	60.9	1.5	19.7	1.0	674.2	2.45E-04	4.50E-04	0.045	4.58E-02	9.4	3.71E-02	0.01
11.0	1.0	10.5	100.1	0.52	0.35	0.217	9	1.25	60.9	1.4	18.9	1.0	699.6	2.57E-04	4.50E-04	0.045	4.82E-02	9.4	3.91E-02	0.01
12.0	1.0	11.5	100.1	0.57	0.38	0.238	9	1.25	60.9	1.4	18.2	1.0	723.7	2.68E-04	4.50E-04	0.045	5.04E-02	9.4	4.09E-02	0.01
13.0	1.0	12.5	99.6	0.62	0.41	0.258	15.4	1.25	75.9	1.3	32.1	1.0	912.0	2.27E-04	4.50E-04	0.045	2.55E-02	9.4	2.07E-02	0.00
14.0	1.0	13.5	99.6	0.67	0.45	0.278	15.4	1.25	75.9	1.3	31.0	1.0	937.9	2.35E-04	4.50E-04	0.045	2.66E-02	9.4	2.15E-02	0.01
15.0	1.0	14.5	99.3	0.71	0.48	0.298	12	1.25	65.0	1.2	23.1	1.0	881.1	2.64E-04	4.50E-04	0.045	3.78E-02	9.4	3.07E-02	0.01
16.0	1.0	15.5	99.3	0.76	0.51	0.318	12	1.25	65.0	1.2	22.5	1.0	902.8	2.71E-04	3.70E-04	0.037	3.22E-02	9.4	2.61E-02	0.01
17.0	1.0	16.5	99.3	0.81	0.55	0.338	12	1.25	65.0	1.1	21.9	1.0	923.7	2.77E-04	3.70E-04	0.037	3.32E-02	9.4	2.69E-02	0.01
18.5	1.5	17.8	99.3	0.88	0.59	0.362	12	1.25	65.0	1.1	21.2	1.0	948.7	2.84E-04	3.70E-04	0.037	3.44E-02	9.4	2.79E-02	0.01
19.0	0.5	18.8	99.3	0.93	0.62	0.381	10	1.25	55.7	1.1	15.3	1.0	873.1	3.21E-04	7.10E-04	0.071	9.83E-02	9.4	7.97E-02	0.01
20.0	1.0	19.5	99.3	0.96	0.65	0.395	10	1.25	55.7	1.0	14.8	1.0	881.1	3.26E-04	7.10E-04	0.071	1.02E-01	9.4	8.28E-02	0.02
21.0	1.0	20.5	99.3	1.01	0.68	0.414	10	1.25	55.7	1.0	14.4	1.0	896.2	3.32E-04	7.10E-04	0.071	1.05E-01	9.4	8.53E-02	0.00
22.0	1.0	21.5	99.3	1.06	0.71	0.433	10	1.25	55.7	1.0	14.1	1.0	910.9	3.37E-04	7.10E-04	0.071	1.08E-01	9.4	8.76E-02	0.00
23.0	1.0	22.5	115.2	1.12	0.75	0.453	32.45	1.25	98.8	1.0	43.7	0.9	1361.2	2.33E-04	3.70E-04	0.037	1.45E-02	9.4	1.18E-02	0.00
24.0	1.0	23.5	115.2	1.17	0.79	0.474	32.45	1.25	98.8	0.9	42.6	0.9	1384.3	2.37E-04	3.70E-04	0.037	1.49E-02	9.4	1.21E-02	0.00
25.0	1.0	24.5	115.2	1.23	0.83	0.495	25	1.25	85.6	0.9	33.0	0.9	1302.1	2.60E-04	3.70E-04	0.037	2.03E-02	9.4	1.65E-02	0.00
26.0	1.0	25.5	115.2	1.29	0.86	0.516	25	1.25	85.6	0.9	32.2	0.9	1322.1	2.64E-04	3.70E-04	0.037	2.09E-02	9.4	1.69E-02	0.00
27.0	1.0	26.5	121.2	1.35	0.90	0.537	55	1.25	124.5	0.9	71.1	0.9	1759.8	2.04E-04	3.70E-04	0.037	8.08E-03	9.4	6.55E-03	0.00
28.0	1.0	27.5	121.2	1.41	0.94	0.558	55	1.25	124.5	0.9	69.5	0.9	1785.8	2.07E-04	3.70E-04	0.037	8.29E-03	9.4	6.72E-03	0.00
29.0	1.0	28.5	121.2	1.47	0.98	0.579	55	1.25	124.5	0.8	68.1	0.9	1811.0	2.09E-04	3.70E-04	0.037	8.51E-03	9.4	6.90E-03	0.00
30.0	1.0	29.5	121.2	1.53	1.02	0.600	55	1.25	124.5	0.8	66.7	0.9	1835.6	2.12E-04	3.00E-04	0.030	7.07E-03	9.4	5.73E-03	0.00
31.0	1.0	30.5	118.6	1.59	1.07	0.620	100	1.25	165.6	0.8	121.6	0.9	2285.3	1.74E-04	1.30E-04	0.013	1.49E-03	9.4	1.21E-03	0.00
32.0	1.0	31.5	118.6	1.65	1.10	0.639	100	1.25	165.6	0.8	119.3	0.9	2313.3	1.76E-04	1.30E-04	0.013	1.52E-03	9.4	1.24E-03	0.00
33.0	1.0	32.5	118.6	1.71	1.14	0.659	100	1.25	165.6	0.8	117.3	0.9	2340.8	1.77E-04	1.30E-04	0.013	1.56E-03	9.4	1.26E-03	0.00
34.0	1.0	33.5	118.6	1.77	1.18	0.677	100	1.25	165.6	0.8	115.3	0.9	2367.5	1.79E-04	1.30E-04	0.013	1.59E-03	9.4	1.29E-03	0.00
35.0	1.0	34.5	118.6	1.83	1.22	0.696	100	1.25	165.6	0.8	113.4	0.9	2393.7	1.80E-04	1.30E-04	0.013	1.62E-03	9.4	1.31E-03	0.00
36.0	1.0	35.5	118.6	1.89	1.26	0.714	100	1.25	160.6	0.7	111.6	0.9	2419.3	1.81E-04	1.30E-04	0.013	1.65E-03	9.4	1.34E-03	0.00
37.0	1.0	36.5	118.6	1.95	1.30	0.732	100	1.25	160.6	0.7	109.9	0.9	2444.4	1.82E-04	1.30E-04	0.013	1.68E-03	9.4	1.36E-03	0.00
38.0	1.0	37.5	118.6	2.00	1.34	0.749	100	1.25	160.6	0.7	108.2	0.9	2469.0	1.83E-04	1.30E-04	0.013	1.71E-03	9.4	1.39E-03	0.00
39.0	1.0	38.5	104.0	2.06	1.38	0.765	100	1.25	160.6	0.7	106.8	0.9	2491.6	1.84E-04	1.30E-04	0.013	1.74E-03	9.4	1.41E-03	0.00
40.0	1.0	39.5	104.0	2.11	1.42	0.779	100	1.25	160.6	0.7	105.4	0.9	2512.4	1.84E-04	1.30E-04	0.013	1.77E-03	9.4	1.43E-03	0.00
41.0	1.0	40.5	104.0	2.16	1.45	0.792	100	1.25	156.3	0.7	104.2	0.8	2532.9	1.84E-04	1.30E-04	0.013	1.79E-03	9.4	1.45E-03	0.00
42.0	1.0	41.5	104.0	2.22	1.49	0.806	100	1.25	156.3	0.7	102.9	0.8	2553.0	1.85E-04	1.30E-04	0.013	1.82E-03	9.4	1.48E-03	0.00
43.0	1.0	42.5	104.0	2.27	1.52	0.819	100	1.25	156.3	0.7	101.8	0.8	2572.8	1.85E-04	1.30E-04	0.013	1.85E-03	9.4	1.50E-03	0.00
44.0	1.0	43.5	104.0	2.32	1.55	0.832	100	1.25	156.3	0.7	100.6	0.8	2592.3	1.85E-04	1.30E-04	0.013	1.87E-03	9.4	1.52E-03	0.00
45.0	1.0	44.5	104.0	2.37	1.59	0.844	100	1.25	156.3	0.7	99.5	0.8	2611.5	1.85E-04	1.30E-04	0.013	1.90E-03	9.4	1.54E-03	0.00
46.0	1.0	45.5	104.0	2.42	1.62	0.856	100	1.25	153.1	0.7	98.4	0.8	2630.5	1.86E-04	1.30E-04	0.013	1.92E-03	9.4	1.56E-03	0.00
47.0	1.0	46.5	104.0	2.48	1.66	0.868	100	1.25	153.1	0.6	97.4	0.8	2649.2	1.86E-04	1.30E-04	0.013	1.95E-03	9.4	1.58E-03	0.00
48.0	1.0	47.5	104.0	2.53	1.69	0.879	100	1.25	153.1	0.6	96.4	0.8	2667.6	1.86E-04	1.30E-04	0.013	1.97E-03	9.4	1.60E-03	0.00
49.0	1.0	48.5	104.0	2.58	1.73	0.890	100	1.25	153.1	0.6	95.4	0.8	2685.7	1.86E-04	1.30E-04	0.013	1.99E-03	9.4	1.62E-03	0.00
50.0	1.0	49.5	104.0	2.63	1.76	0.901	100	1.25	153.1	0.6	94.5	0.8	2703.7	1.86E-04	1.30E-04	0.013	2.02E-03	9.4	1.64E-03	0.00

TOTAL SETTLEMENT = **0.13**

TECHNICAL ENGINEERING AND DESIGN GUIDES AS ADAPTED FROM THE US ARMY CORPS OF ENGINEERS, NO. 9 EVALUATION OF EARTHQUAKE-INDUCED SETTLEMENTS IN DRY SANDY SOILS DESIGN EARTHQUAKE

DE EARTHQUAKE INFORMATION:

Earthquake Magnitude:	6.81
Peak Horiz. Acceleration (g):	0.656

Fig 4.1 Fig 4.2

Fig 4.4

Depth of Base of Strata (ft)	Thickness of Layer (ft)	Depth of Mid-point of Layer (ft)	Soil Unit Weight (pcf)	Overburden Pressure at Mid-point (tsf)	Mean Effective Pressure at Mid-point (tsf)	Average Cyclic Shear Stress [Tav] (tsf)	Field SPT [N]	Correction Factor [Cer]	Relative Density [Dr] (%)	Correction Factor [Cn]	Corrected [N]60	rd Factor	Maximum Shear Mod. [Gmax] (tsf)	yeff *[Geff] [Gmax]	yeff Shear Strain	veff *100%	Volumetric Strain M7.5 [E15] (%)	Number of Strain Cycles [Nc]	Corrected Vol. Strains [Ec]	Estimated Settlement [S] (inches)
1.0	1.0	0.5	85.2	0.02	0.01	0.009	4	1.25	45.0	1.7	14.2	1.0	129.2	6.95E-05	1.00E-04	0.010	1.51E-02	9.4	1.23E-02	Grading
2.0	1.0	1.5	85.2	0.06	0.04	0.027	4	1.25	45.0	1.7	14.2	1.0	223.9	1.18E-04	2.30E-04	0.023	3.47E-02	9.4	2.82E-02	Grading
3.0	1.0	2.5	85.2	0.11	0.07	0.045	4	1.25	45.0	1.7	14.2	1.0	289.0	1.49E-04	2.30E-04	0.023	3.47E-02	9.4	2.82E-02	Grading
4.0	1.0	3.5	85.2	0.15	0.10	0.063	4	1.25	45.0	1.7	14.2	1.0	342.0	1.73E-04	2.30E-04	0.023	3.47E-02	9.4	2.82E-02	Grading
5.0	1.0	4.5	85.2	0.19	0.13	0.082	4	1.25	45.0	1.7	14.2	1.0	387.7	1.93E-04	1.70E-04	0.017	2.57E-02	9.4	2.08E-02	Grading
6.0	1.0	5.5	85.2	0.23	0.16	0.100	4	1.25	45.0	1.7	14.2	1.0	428.7	2.09E-04	8.10E-04	0.081	1.22E-01	9.4	9.92E-02	Grading
7.5	1.5	6.8	85.2	0.29	0.19	0.122	4	1.25	45.0	1.7	14.2	1.0	474.9	2.26E-04	8.10E-04	0.081	1.22E-01	9.4	9.92E-02	0.04
8.0	0.5	7.8	85.2	0.33	0.22	0.140	4	1.25	45.0	1.7	14.2	1.0	508.9	2.38E-04	4.50E-04	0.045	6.80E-02	9.4	5.51E-02	0.01
9.0	1.0	8.5	85.2	0.36	0.24	0.153	4	1.25	45.0	1.7	14.2	1.0	532.8	2.46E-04	4.50E-04	0.045	6.81E-02	9.4	5.52E-02	0.01
10.0	1.0	9.5	79.4	0.40	0.27	0.170	7	1.25	54.9	1.6	12.8	1.0	542.9	2.64E-04	4.50E-04	0.045	7.72E-02	9.4	6.26E-02	0.02
11.0	1.0	10.5	79.4	0.44	0.30	0.187	7	1.25	54.9	1.5	12.2	1.0	560.2	2.76E-04	4.50E-04	0.045	8.16E-02	9.4	6.62E-02	0.02
12.0	1.0	11.5	96.4	0.49	0.33	0.205	9	1.25	60.5	1.5	22.8	1.0	723.9	2.31E-04	4.50E-04	0.045	3.85E-02	9.4	3.12E-02	0.01
13.0	1.0	12.5	96.4	0.54	0.36	0.225	9	1.25	60.5	1.4	22.0	1.0	749.6	2.40E-04	4.50E-04	0.045	4.02E-02	9.4	3.26E-02	0.01
14.0	1.0	13.5	96.4	0.58	0.39	0.244	9	1.25	60.5	1.3	21.3	1.0	774.1	2.49E-04	4.50E-04	0.045	4.18E-02	9.4	3.39E-02	0.01
15.0	1.0	14.5	96.4	0.63	0.42	0.264	9	1.25	60.5	1.3	20.6	1.0	797.3	2.57E-04	4.50E-04	0.045	4.34E-02	9.4	3.52E-02	0.01
16.0	1.0	15.5	96.4	0.68	0.46	0.283	2	1.25	26.1	1.2	8.8	1.0	623.2	3.48E-04	1.00E-03	0.100	2.67E-01	9.4	2.17E-01	0.05
17.0	1.0	16.5	96.4	0.73	0.49	0.302	2	1.25	26.1	1.2	8.7	1.0	641.7	3.56E-04	1.00E-03	0.100	2.72E-01	9.4	2.21E-01	0.05
18.0	1.0	17.5	96.4	0.78	0.52	0.321	2	1.25	26.1	1.2	8.1	1.0	648.5	3.69E-04	7.10E-04	0.071	2.09E-01	9.4	1.69E-01	0.04
19.0	1.0	18.5	107.0	0.83	0.55	0.341	12.1	1.25	62.6	1.1	25.8	1.0	982.8	2.55E-04	3.70E-04	0.037	2.73E-02	9.4	2.21E-02	0.01
20.0	1.0	19.5	107.0	0.88	0.59	0.361	12.1	1.25	62.6	1.1	25.1	1.0	1005.5	2.61E-04	3.70E-04	0.037	2.81E-02	9.4	2.28E-02	0.01
21.0	1.0	20.5	107.0	0.93	0.63	0.382	12.1	1.25	62.6	1.1	24.5	1.0	1027.4	2.67E-04	3.70E-04	0.037	2.90E-02	9.4	2.35E-02	0.00
22.0	1.0	21.5	114.1	0.99	0.66	0.403	24	1.25	86.5	1.0	34.3	1.0	1182.5	2.42E-04	3.70E-04	0.037	1.94E-02	9.4	1.57E-02	0.00
23.0	1.0	22.5	114.1	1.05	0.70	0.424	24	1.25	86.5	1.0	33.4	0.9	1204.8	2.47E-04	3.70E-04	0.037	2.00E-02	9.4	1.62E-02	0.00
24.0	1.0	23.5	114.1	1.10	0.74	0.446	24	1.25	86.5	1.0	32.5	0.9	1226.3	2.51E-04	3.70E-04	0.037	2.07E-02	9.4	1.68E-02	0.00
25.0	1.0	24.5	114.1	1.16	0.78	0.467	24	1.25	86.5	0.9	31.7	0.9	1247.1	2.56E-04	3.70E-04	0.037	2.13E-02	9.4	1.73E-02	0.00
26.0	1.0	25.5	114.1	1.22	0.82	0.487	55	1.25	129.3	0.9	73.0	0.9	1687.1	1.95E-04	1.60E-04	0.016	3.38E-03	9.4	2.74E-03	0.00
27.0	1.0	26.5	114.1	1.27	0.85	0.508	55	1.25	129.3	0.9	71.3	0.9	1713.1	1.98E-04	1.60E-04	0.016	3.48E-03	9.4	2.82E-03	0.00
28.0	1.0	27.5	114.1	1.33	0.89	0.528	49	1.25	119.7	0.9	63.7	0.9	1686.4	2.07E-04	3.70E-04	0.037	9.21E-03	9.4	7.47E-03	0.00
29.0	1.0	28.5	114.1	1.39	0.93	0.547	49	1.25	119.7	0.9	62.4	0.9	1710.1	2.10E-04	3.70E-04	0.037	9.45E-03	9.4	7.66E-03	0.00
30.0	1.0	29.5	114.1	1.45	0.97	0.567	49	1.25	119.7	0.8	61.2	0.9	1733.2	2.12E-04	3.70E-04	0.037	9.68E-03	9.4	7.85E-03	0.00
31.0	1.0	30.5	120.7	1.50	1.01	0.587	49	1.25	119.7	0.8	60.0	0.9	1756.4	2.14E-04	3.00E-04	0.030	8.04E-03	9.4	6.52E-03	0.00
32.0	1.0	31.5	120.7	1.56	1.05	0.607	49	1.25	119.7	0.8	58.8	0.9	1779.5	2.17E-04	3.00E-04	0.030	8.23E-03	9.4	6.67E-03	0.00
33.0	1.0	32.5	120.7	1.63	1.09	0.626	31	1.25	92.2	0.8	37.3	0.9	1558.0	2.53E-04	3.00E-04	0.030	1.42E-02	9.4	1.15E-02	0.00
34.0	1.0	33.5	120.7	1.69	1.13	0.646	31	1.25	92.2	0.8	36.6	0.9	1577.0	2.56E-04	3.00E-04	0.030	1.45E-02	9.4	1.18E-02	0.00
35.0	1.0	34.5	120.7	1.75	1.17	0.665	31	1.25	92.2	0.8	36.0	0.9	1595.7	2.58E-04	3.00E-04	0.030	1.48E-02	9.4	1.20E-02	0.00
36.0	1.0	35.5	120.7	1.81	1.21	0.684	31	1.25	92.2	0.8	35.4	0.9	1613.8	2.60E-04	3.00E-04	0.030	1.51E-02	9.4	1.23E-02	0.00
37.0	1.0	36.5	120.7	1.87	1.25	0.702	31	1.25	92.2	0.7	34.8	0.9	1631.6	2.62E-04	3.00E-04	0.030	1.54E-02	9.4	1.25E-02	0.00
38.0	1.0	37.5	105.2	1.92	1.29	0.718	41	1.25	102.8	0.7	45.3	0.9	1808.9	2.40E-04	3.00E-04	0.030	1.12E-02	9.4	9.12E-03	0.00
39.0	1.0	38.5	105.2	1.98	1.32	0.733	41	1.25	102.8	0.7	44.7	0.9	1825.2	2.40E-04	3.00E-04	0.030	1.14E-02	9.4	9.26E-03	0.00
40.0	1.0	39.5	105.2	2.03	1.36	0.748	41	1.25	102.8	0.7	44.1	0.9	1841.3	2.41E-04	3.00E-04	0.030	1.16E-02	9.4	9.41E-03	0.00
41.0	1.0	40.5	105.2	2.08	1.39	0.762	41	1.25	102.8	0.7	43.6	0.8	1857.0	2.42E-04	3.00E-04	0.030	1.18E-02	9.4	9.56E-03	0.00
42.0	1.0	41.5	105.2	2.13	1.43	0.776	41	1.25	102.8	0.7	43.0	0.8	1872.6	2.42E-04	3.00E-04	0.030	1.20E-02	9.4	9.70E-03	0.00
43.0	1.0	42.5	109.5	2.19	1.47	0.789	64	1.25	125.5	0.7	66.3	0.8	2190.3	2.10E-04	3.00E-04	0.030	7.12E-03	9.4	5.77E-03	0.00
44.0	1.0	43.5	109.5	2.24	1.50	0.803	64	1.25	125.5	0.7	65.5	0.8	2208.4	2.10E-04	3.00E-04	0.030	7.22E-03	9.4	5.86E-03	0.00
45.0	1.0	44.5	109.5	2.30	1.54	0.817	64	1.25	125.5	0.7	64.7	0.8	2226.2	2.11E-04	3.00E-04	0.030	7.33E-03	9.4	5.94E-03	0.00
46.0	1.0	45.5	109.5	2.35	1.58	0.830	64	1.25	125.5	0.7	64.0	0.8	2243.8	2.11E-04	3.00E-04	0.030	7.43E-03	9.4	6.03E-03	0.00
47.0	1.0	46.5	109.5	2.41	1.61	0.843	64	1.25	125.5	0.7	63.2	0.8	2261.1	2.11E-04	3.00E-04	0.030	7.54E-03	9.4	6.11E-03	0.00
48.0	1.0	47.5	132.6	2.47	1.65	0.858	100	1.25	153.1	0.7	97.6	0.8	2645.6	1.83E-04	1.30E-04	0.013	1.94E-03	9.4	1.57E-03	0.00
49.0	1.0	48.5	132.6	2.53	1.70	0.874	100	1.25	153.1	0.6	96.3	0.8	2669.1	1.83E-04	1.30E-04	0.013	1.97E-03	9.4	1.60E-03	0.00
50.0	1.0	49.5	132.6	2.60	1.74	0.890	100	1.25	153.1	0.6	95.1	0.8	2692.2	1.84E-04	1.30E-04	0.013	2.00E-03	9.4	1.62E-03	0.00

TOTAL SETTLEMENT = **0.27**

Figure 14

TECHNICAL ENGINEERING AND DESIGN GUIDES AS ADAPTED FROM THE US ARMY CORPS OF ENGINEERS, NO. 9 EVALUATION OF EARTHQUAKE-INDUCED SETTLEMENTS IN DRY SANDY SOILS MAXIMUM CONSIDERED EARTHQUAKE

MCE EARTHQUAKE INFORMATION:

Earthquake Magnitude:	6.94
Peak Horiz. Acceleration (g):	0.983

Fig 4.1 Fig 4.2

Fig 4.4

Depth of Base of Strata (ft)	Thickness of Layer (ft)	Depth of Mid-point of Layer (ft)	Soil Unit Weight (pcf)	Overburden Pressure at Mid-point (tsf)	Mean Effective Pressure at Mid-point (tsf)	Average Cyclic Shear Stress [Tav]	Field SPT [N]	Correction Factor [Cer]	Relative Density [Dr] (%)	Correction Factor [Cn]	Corrected [N]60	rd Factor	Maximum Shear Mod. [Gmax] (tsf)	yeff *[Geff] [Gmax]	yeff Shear Strain	veff *100%	Volumetric Strain M7.5 [E15] (%)	Number of Strain Cycles [Nc]	Corrected Vol. Strains [Ec]	Estimated Settlement [S] (inches)
1.0	1.0	0.5	93.4	0.02	0.02	0.015	4	1.25	44.6	1.7	14.2	1.0	135.3	1.09E-04	2.30E-04	0.023	3.47E-02	10.4	2.94E-02	Grading
2.0	1.0	1.5	93.4	0.07	0.05	0.045	4	1.25	44.6	1.7	14.2	1.0	234.4	1.85E-04	2.30E-04	0.023	3.47E-02	10.4	2.94E-02	Grading
3.0	1.0	2.5	93.4	0.12	0.08	0.075	4	1.25	44.6	1.7	14.2	1.0	302.6	2.35E-04	3.00E-03	0.300	4.53E-01	10.4	3.84E-01	Grading
4.0	1.0	3.5	100.1	0.17	0.11	0.105	4	1.25	44.6	1.7	14.2	1.0	359.9	2.74E-04	8.10E-04	0.081	1.22E-01	10.4	1.04E-01	Grading
5.0	1.0	4.5	100.1	0.22	0.14	0.137	4	1.25	44.6	1.7	14.2	1.0	410.8	3.06E-04	5.00E-03	0.500	7.55E-01	10.4	6.40E-01	Grading
6.0	1.0	5.5	100.1	0.27	0.18	0.169	4	1.25	44.6	1.7	14.2	1.0	456.1	3.34E-04	5.00E-03	0.500	7.55E-01	10.4	6.40E-01	Grading
7.0	1.0	6.5	100.1	0.32	0.21	0.201	4	1.25	44.6	1.7	14.2	1.0	497.3	3.57E-04	1.00E-03	0.100	1.51E-01	10.4	1.28E-01	0.03
8.0	1.0	7.5	100.1	0.37	0.24	0.232	4	1.25	44.6	1.7	14.1	1.0	534.6	3.78E-04	1.00E-03	0.100	1.52E-01	10.4	1.29E-01	0.03
9.0	1.0	8.5	100.1	0.42	0.28	0.264	9	1.25	60.9	1.6	20.7	1.0	647.0	3.48E-04	1.00E-03	0.100	9.62E-02	10.4	8.15E-02	0.02
10.0	1.0	9.5	100.1	0.47	0.31	0.295	9	1.25	60.9	1.5	19.7	1.0	674.2	3.68E-04	1.00E-03	0.100	1.02E-01	10.4	8.63E-02	0.02
11.0	1.0	10.5	100.1	0.52	0.35	0.326	9	1.25	60.9	1.4	18.9	1.0	699.6	3.86E-04	1.00E-03	0.100	1.07E-01	10.4	9.07E-02	0.02
12.0	1.0	11.5	100.1	0.57	0.38	0.357	9	1.25	60.9	1.4	18.2	1.0	723.7	4.02E-04	2.70E-03	0.270	3.03E-01	10.4	2.56E-01	0.06
13.0	1.0	12.5	99.6	0.62	0.41	0.387	15.4	1.25	75.9	1.3	32.1	1.0	912.0	3.41E-04	1.00E-03	0.100	5.67E-02	10.4	4.81E-02	0.01
14.0	1.0	13.5	99.6	0.67	0.45	0.417	15.4	1.25	75.9	1.3	31.0	1.0	937.9	3.52E-04	1.00E-03	0.100	5.90E-02	10.4	5.00E-02	0.01
15.0	1.0	14.5	99.3	0.71	0.48	0.447	12	1.25	65.0	1.2	23.1	1.0	881.1	3.95E-04	1.00E-03	0.100	8.41E-02	10.4	7.13E-02	0.02
16.0	1.0	15.5	99.3	0.76	0.51	0.477	12	1.25	65.0	1.2	22.5	1.0	902.8	4.06E-04	1.20E-03	0.120	1.04E-01	10.4	8.84E-02	0.02
17.0	1.0	16.5	99.3	0.81	0.55	0.506	12	1.25	65.0	1.1	21.9	1.0	923.7	4.15E-04	1.20E-03	0.120	1.08E-01	10.4	9.12E-02	0.02
18.5	1.5	17.8	99.3	0.88	0.59	0.543	12	1.25	65.0	1.1	21.2	1.0	948.7	4.26E-04	1.20E-03	0.120	1.12E-01	10.4	9.46E-02	0.03
19.0	0.5	18.8	99.3	0.93	0.62	0.572	10	1.25	55.7	1.1	15.3	1.0	873.1	4.81E-04	1.20E-03	0.120	1.66E-01	10.4	1.41E-01	0.02
20.0	1.0	19.5	99.3	0.96	0.65	0.593	10	1.25	55.7	1.0	14.8	1.0	881.1	4.89E-04	1.20E-03	0.120	1.73E-01	10.4	1.46E-01	0.04
21.0	1.0	20.5	99.3	1.01	0.68	0.621	10	1.25	55.7	1.0	14.4	1.0	896.2	4.97E-04	1.20E-03	0.120	1.78E-01	10.4	1.51E-01	0.00
22.0	1.0	21.5	99.3	1.06	0.71	0.649	10	1.25	55.7	1.0	14.1	1.0	910.9	5.05E-04	2.20E-03	0.220	3.35E-01	10.4	2.84E-01	0.00
23.0	1.0	22.5	115.2	1.12	0.75	0.679	32.45	1.25	98.8	1.0	43.7	0.9	1361.2	3.49E-04	7.10E-04	0.071	2.78E-02	10.4	2.36E-02	0.00
24.0	1.0	23.5	115.2	1.17	0.79	0.711	32.45	1.25	98.8	0.9	42.6	0.9	1384.3	3.55E-04	7.10E-04	0.071	2.87E-02	10.4	2.43E-02	0.00
25.0	1.0	24.5	115.2	1.23	0.83	0.742	25	1.25	85.6	0.9	33.0	0.9	1302.1	3.90E-04	7.10E-04	0.071	3.89E-02	10.4	3.30E-02	0.00
26.0	1.0	25.5	115.2	1.29	0.86	0.773	25	1.25	85.6	0.9	32.2	0.9	1322.1	3.96E-04	7.10E-04	0.071	4.00E-02	10.4	3.39E-02	0.00
27.0	1.0	26.5	121.2	1.35	0.90	0.805	55	1.25	124.5	0.9	71.1	0.9	1759.8	3.06E-04	7.10E-04	0.071	1.55E-02	10.4	1.31E-02	0.00
28.0	1.0	27.5	121.2	1.41	0.94	0.837	55	1.25	124.5	0.9	69.5	0.9	1785.8	3.10E-04	7.10E-04	0.071	1.59E-02	10.4	1.35E-02	0.00
29.0	1.0	28.5	121.2	1.47	0.98	0.868	55	1.25	124.5	0.8	68.1	0.9	1811.0	3.14E-04	7.10E-04	0.071	1.63E-02	10.4	1.38E-02	0.00
30.0	1.0	29.5	121.2	1.53	1.02	0.899	55	1.25	124.5	0.8	66.7	0.9	1835.6	3.18E-04	5.20E-04	0.052	1.22E-02	10.4	1.04E-02	0.00
31.0	1.0	30.5	118.6	1.59	1.07	0.929	100	1.25	165.6	0.8	121.6	0.9	2285.3	2.61E-04	3.00E-04	0.030	3.44E-03	10.4	2.92E-03	0.00
32.0	1.0	31.5	118.6	1.65	1.10	0.959	100	1.25	165.6	0.8	119.3	0.9	2313.3	2.63E-04	3.00E-04	0.030	3.52E-03	10.4	2.98E-03	0.00
33.0	1.0	32.5	118.6	1.71	1.14	0.987	100	1.25	165.6	0.8	117.3	0.9	2340.8	2.66E-04	3.00E-04	0.030	3.59E-03	10.4	3.04E-03	0.00
34.0	1.0	33.5	118.6	1.77	1.18	1.016	100	1.25	165.6	0.8	115.3	0.9	2367.5	2.68E-04	3.00E-04	0.030	3.67E-03	10.4	3.11E-03	0.00
35.0	1.0	34.5	118.6	1.83	1.22	1.043	100	1.25	165.6	0.8	113.4	0.9	2393.7	2.70E-04	3.00E-04	0.030	3.74E-03	10.4	3.17E-03	0.00
36.0	1.0	35.5	118.6	1.89	1.26	1.070	100	1.25	160.6	0.7	111.6	0.9	2419.3	2.71E-04	3.00E-04	0.030	3.81E-03	10.4	3.23E-03	0.00
37.0	1.0	36.5	118.6	1.95	1.30	1.097	100	1.25	160.6	0.7	109.9	0.9	2444.4	2.73E-04	3.00E-04	0.030	3.88E-03	10.4	3.29E-03	0.00
38.0	1.0	37.5	118.6	2.00	1.34	1.123	100	1.25	160.6	0.7	108.2	0.9	2469.0	2.74E-04	3.00E-04	0.030	3.95E-03	10.4	3.35E-03	0.00
39.0	1.0	38.5	104.0	2.06	1.38	1.147	100	1.25	160.6	0.7	106.8	0.9	2491.6	2.75E-04	3.00E-04	0.030	4.02E-03	10.4	3.41E-03	0.00
40.0	1.0	39.5	104.0	2.11	1.42	1.168	100	1.25	160.6	0.7	105.4	0.9	2512.4	2.76E-04	3.00E-04	0.030	4.08E-03	10.4	3.46E-03	0.00
41.0	1.0	40.5	104.0	2.16	1.45	1.188	100	1.25	156.3	0.7	104.2	0.8	2532.9	2.77E-04	3.00E-04	0.030	4.14E-03	10.4	3.51E-03	0.00
42.0	1.0	41.5	104.0	2.22	1.49	1.208	100	1.25	156.3	0.7	102.9	0.8	2553.0	2.77E-04	3.00E-04	0.030	4.20E-03	10.4	3.56E-03	0.00
43.0	1.0	42.5	104.0	2.27	1.52	1.228	100	1.25	156.3	0.7	101.8	0.8	2572.8	2.77E-04	3.00E-04	0.030	4.26E-03	10.4	3.61E-03	0.00
44.0	1.0	43.5	104.0	2.32	1.55	1.247	100	1.25	156.3	0.7	100.6	0.8	2592.3	2.78E-04	3.00E-04	0.030	4.32E-03	10.4	3.66E-03	0.00
45.0	1.0	44.5	104.0	2.37	1.59	1.265	100	1.25	156.3	0.7	99.5	0.8	2611.5	2.78E-04	3.00E-04	0.030	4.37E-03	10.4	3.71E-03	0.00
46.0	1.0	45.5	104.0	2.42	1.62	1.283	100	1.25	153.1	0.7	98.4	0.8	2630.5	2.78E-04	3.00E-04	0.030	4.43E-03	10.4	3.76E-03	0.00
47.0	1.0	46.5	104.0	2.48	1.66	1.301	100	1.25	153.1	0.6	97.4	0.8	2649.2	2.78E-04	3.00E-04	0.030	4.49E-03	10.4	3.80E-03	0.00
48.0	1.0	47.5	104.0	2.53	1.69	1.318	100	1.25	153.1	0.6	96.4	0.8	2667.6	2.78E-04	3.00E-04	0.030	4.55E-03	10.4	3.85E-03	0.00
49.0	1.0	48.5	104.0	2.58	1.73	1.335	100	1.25	153.1	0.6	95.4	0.8	2685.7	2.78E-04	3.00E-04	0.030	4.60E-03	10.4	3.90E-03	0.00
50.0	1.0	49.5	104.0	2.63	1.76	1.351	100	1.25	153.1	0.6	94.5	0.8	2703.7	2.78E-04	3.00E-04	0.030	4.66E-03	10.4	3.95E-03	0.00

TOTAL SETTLEMENT = **0.35**

Figure 15

TECHNICAL ENGINEERING AND DESIGN GUIDES AS ADAPTED FROM THE US ARMY CORPS OF ENGINEERS, NO. 9 EVALUATION OF EARTHQUAKE-INDUCED SETTLEMENTS IN DRY SANDY SOILS MAXIMUM CONSIDERED EARTHQUAKE

MCE EARTHQUAKE INFORMATION:

Earthquake Magnitude:	6.94
Peak Horiz. Acceleration (g):	0.983

Fig 4.1 Fig 4.2

Fig 4.4

Depth of Base of Strata (ft)	Thickness of Layer (ft)	Depth of Mid-point of Layer (ft)	Soil Unit Weight (pcf)	Overburden Pressure at Mid-point (tsf)	Mean Effective Pressure at Mid-point (tsf)	Average Cyclic Shear Stress [Tav] (tsf)	Field SPT [N]	Correction Factor [Ccr]	Relative Density [Dr] (%)	Correction Factor [Cn]	Corrected [N]60	rd Factor	Maximum Shear Mod. [Gmax] (tsf)	γ _{eff} *[G _{eff}] [Gmax]	γ _{eff} Shear Strain	γ _{eff} *100%	Volumetric Strain M7.5 [E15] (%)	Number of Strain Cycles [Nc]	Corrected Vol. Strains [Ec]	Estimated Settlement [S] (inches)
1.0	1.0	0.5	85.2	0.02	0.01	0.014	4	1.25	45.0	1.7	14.2	1.0	129.2	1.04E-04	2.30E-04	0.023	3.47E-02	10.4	2.94E-02	Grading
2.0	1.0	1.5	85.2	0.06	0.04	0.041	4	1.25	45.0	1.7	14.2	1.0	223.9	1.77E-04	2.30E-04	0.023	3.47E-02	10.4	2.94E-02	Grading
3.0	1.0	2.5	85.2	0.11	0.07	0.068	4	1.25	45.0	1.7	14.2	1.0	289.0	2.24E-04	3.00E-03	0.300	4.53E-01	10.4	3.84E-01	Grading
4.0	1.0	3.5	85.2	0.15	0.10	0.095	4	1.25	45.0	1.7	14.2	1.0	342.0	2.60E-04	3.00E-03	0.300	4.53E-01	10.4	3.84E-01	Grading
5.0	1.0	4.5	85.2	0.19	0.13	0.122	4	1.25	45.0	1.7	14.2	1.0	387.7	2.89E-04	8.10E-04	0.081	1.22E-01	10.4	1.04E-01	Grading
6.0	1.0	5.5	85.2	0.23	0.16	0.149	4	1.25	45.0	1.7	14.2	1.0	428.7	3.14E-04	5.00E-03	0.500	7.55E-01	10.4	6.40E-01	Grading
7.5	1.5	6.8	85.2	0.29	0.19	0.183	4	1.25	45.0	1.7	14.2	1.0	474.9	3.40E-04	5.00E-03	0.500	7.55E-01	10.4	6.40E-01	0.23
8.0	0.5	7.8	85.2	0.33	0.22	0.210	4	1.25	45.0	1.7	14.2	1.0	508.9	3.57E-04	1.00E-03	0.100	1.51E-01	10.4	1.28E-01	0.02
9.0	1.0	8.5	85.2	0.36	0.24	0.230	4	1.25	45.0	1.7	14.2	1.0	532.8	3.69E-04	1.00E-03	0.100	1.51E-01	10.4	1.28E-01	0.03
10.0	1.0	9.5	79.4	0.40	0.27	0.255	7	1.25	54.9	1.6	12.8	1.0	542.9	3.96E-04	1.00E-03	0.100	1.71E-01	10.4	1.45E-01	0.03
11.0	1.0	10.5	79.4	0.44	0.30	0.280	7	1.25	54.9	1.5	12.2	1.0	560.2	4.14E-04	2.70E-03	0.270	4.90E-01	10.4	4.15E-01	0.10
12.0	1.0	11.5	96.4	0.49	0.33	0.307	9	1.25	60.5	1.5	22.8	1.0	723.9	3.46E-04	1.00E-03	0.100	8.55E-02	10.4	7.24E-02	0.02
13.0	1.0	12.5	96.4	0.54	0.36	0.337	9	1.25	60.5	1.4	22.0	1.0	749.6	3.60E-04	1.00E-03	0.100	8.93E-02	10.4	7.57E-02	0.02
14.0	1.0	13.5	96.4	0.58	0.39	0.366	9	1.25	60.5	1.3	21.3	1.0	774.1	3.74E-04	1.00E-03	0.100	9.30E-02	10.4	7.88E-02	0.02
15.0	1.0	14.5	96.4	0.63	0.42	0.395	9	1.25	60.5	1.3	20.6	1.0	797.3	3.86E-04	1.00E-03	0.100	9.64E-02	10.4	8.17E-02	0.02
16.0	1.0	15.5	96.4	0.68	0.46	0.424	2	1.25	26.1	1.2	8.8	1.0	623.2	5.22E-04	1.00E-02	1.000	2.67E+00	10.4	2.26E+00	0.54
17.0	1.0	16.5	96.4	0.73	0.49	0.453	2	1.25	26.1	1.2	8.7	1.0	641.7	5.34E-04	1.00E-02	1.000	2.72E+00	10.4	2.30E+00	0.55
18.0	1.0	17.5	96.4	0.78	0.52	0.481	2	1.25	26.1	1.2	8.1	1.0	648.5	5.54E-04	2.20E-03	0.220	6.47E-01	10.4	5.48E-01	0.13
19.0	1.0	18.5	107.0	0.83	0.55	0.511	12.1	1.25	62.6	1.1	25.8	1.0	982.8	3.83E-04	7.10E-04	0.071	5.24E-02	10.4	4.44E-02	0.01
20.0	1.0	19.5	107.0	0.88	0.59	0.542	12.1	1.25	62.6	1.1	25.1	1.0	1005.5	3.92E-04	7.10E-04	0.071	5.40E-02	10.4	4.58E-02	0.01
21.0	1.0	20.5	107.0	0.93	0.63	0.573	12.1	1.25	62.6	1.1	24.5	1.0	1027.4	4.00E-04	1.20E-03	0.120	9.39E-02	10.4	7.96E-02	0.00
22.0	1.0	21.5	114.1	0.99	0.66	0.604	24	1.25	86.5	1.0	34.3	1.0	1182.5	3.62E-04	7.10E-04	0.071	3.72E-02	10.4	3.15E-02	0.00
23.0	1.0	22.5	114.1	1.05	0.70	0.636	24	1.25	86.5	1.0	33.4	0.9	1204.8	3.70E-04	7.10E-04	0.071	3.84E-02	10.4	3.26E-02	0.00
24.0	1.0	23.5	114.1	1.10	0.74	0.668	24	1.25	86.5	1.0	32.5	0.9	1226.3	3.77E-04	7.10E-04	0.071	3.97E-02	10.4	3.36E-02	0.00
25.0	1.0	24.5	114.1	1.16	0.78	0.699	24	1.25	86.5	0.9	31.7	0.9	1247.1	3.84E-04	7.10E-04	0.071	4.09E-02	10.4	3.47E-02	0.00
26.0	1.0	25.5	114.1	1.22	0.82	0.730	55	1.25	129.3	0.9	73.0	0.9	1687.1	2.93E-04	3.70E-04	0.037	7.83E-03	10.4	6.63E-03	0.00
27.0	1.0	26.5	114.1	1.27	0.85	0.761	55	1.25	129.3	0.9	71.3	0.9	1713.1	2.97E-04	3.70E-04	0.037	8.04E-03	10.4	6.82E-03	0.00
28.0	1.0	27.5	114.1	1.33	0.89	0.791	49	1.25	119.7	0.9	63.7	0.9	1686.4	3.10E-04	7.10E-04	0.071	1.77E-02	10.4	1.50E-02	0.00
29.0	1.0	28.5	114.1	1.39	0.93	0.821	49	1.25	119.7	0.9	62.4	0.9	1710.1	3.14E-04	7.10E-04	0.071	1.81E-02	10.4	1.54E-02	0.00
30.0	1.0	29.5	114.1	1.45	0.97	0.850	49	1.25	119.7	0.8	61.2	0.9	1733.2	3.18E-04	7.10E-04	0.071	1.86E-02	10.4	1.57E-02	0.00
31.0	1.0	30.5	120.7	1.50	1.01	0.879	49	1.25	119.7	0.8	60.0	0.9	1756.4	3.21E-04	5.20E-04	0.052	1.39E-02	10.4	1.18E-02	0.00
32.0	1.0	31.5	120.7	1.56	1.05	0.910	49	1.25	119.7	0.8	58.8	0.9	1779.5	3.25E-04	5.20E-04	0.052	1.43E-02	10.4	1.21E-02	0.00
33.0	1.0	32.5	120.7	1.63	1.09	0.939	31	1.25	92.2	0.8	37.3	0.9	1558.0	3.80E-04	5.20E-04	0.052	2.46E-02	10.4	2.09E-02	0.00
34.0	1.0	33.5	120.7	1.69	1.13	0.968	31	1.25	92.2	0.8	36.6	0.9	1577.0	3.83E-04	5.20E-04	0.052	2.52E-02	10.4	2.13E-02	0.00
35.0	1.0	34.5	120.7	1.75	1.17	0.997	31	1.25	92.2	0.8	36.0	0.9	1595.7	3.86E-04	5.20E-04	0.052	2.57E-02	10.4	2.18E-02	0.00
36.0	1.0	35.5	120.7	1.81	1.21	1.025	31	1.25	92.2	0.8	35.4	0.9	1613.8	3.89E-04	5.20E-04	0.052	2.62E-02	10.4	2.22E-02	0.00
37.0	1.0	36.5	120.7	1.87	1.25	1.052	31	1.25	92.2	0.7	34.8	0.9	1631.6	3.92E-04	5.20E-04	0.052	2.68E-02	10.4	2.27E-02	0.00
38.0	1.0	37.5	105.2	1.92	1.29	1.077	41	1.25	102.8	0.7	45.3	0.9	1808.9	3.59E-04	5.20E-04	0.052	1.95E-02	10.4	1.65E-02	0.00
39.0	1.0	38.5	105.2	1.98	1.32	1.099	41	1.25	102.8	0.7	44.7	0.9	1825.2	3.61E-04	5.20E-04	0.052	1.98E-02	10.4	1.68E-02	0.00
40.0	1.0	39.5	105.2	2.03	1.36	1.121	41	1.25	102.8	0.7	44.1	0.9	1841.3	3.62E-04	5.20E-04	0.052	2.01E-02	10.4	1.70E-02	0.00
41.0	1.0	40.5	105.2	2.08	1.39	1.142	41	1.25	102.8	0.7	43.6	0.8	1857.0	3.63E-04	5.20E-04	0.052	2.04E-02	10.4	1.73E-02	0.00
42.0	1.0	41.5	105.2	2.13	1.43	1.163	41	1.25	102.8	0.7	43.0	0.8	1872.6	3.64E-04	5.20E-04	0.052	2.07E-02	10.4	1.76E-02	0.00
43.0	1.0	42.5	109.5	2.19	1.47	1.184	64	1.25	125.5	0.7	66.3	0.8	2190.3	3.14E-04	5.20E-04	0.052	1.23E-02	10.4	1.05E-02	0.00
44.0	1.0	43.5	109.5	2.24	1.50	1.204	64	1.25	125.5	0.7	65.5	0.8	2208.4	3.15E-04	5.20E-04	0.052	1.25E-02	10.4	1.06E-02	0.00
45.0	1.0	44.5	109.5	2.30	1.54	1.225	64	1.25	125.5	0.7	64.7	0.8	2226.2	3.16E-04	5.20E-04	0.052	1.27E-02	10.4	1.08E-02	0.00
46.0	1.0	45.5	109.5	2.35	1.58	1.245	64	1.25	125.5	0.7	64.0	0.8	2243.8	3.16E-04	5.20E-04	0.052	1.29E-02	10.4	1.09E-02	0.00
47.0	1.0	46.5	109.5	2.41	1.61	1.264	64	1.25	125.5	0.7	63.2	0.8	2261.1	3.17E-04	5.20E-04	0.052	1.31E-02	10.4	1.11E-02	0.00
48.0	1.0	47.5	132.6	2.47	1.65	1.286	100	1.25	153.1	0.7	97.6	0.8	2645.6	2.74E-04	3.00E-04	0.030	4.48E-03	10.4	3.79E-03	0.00
49.0	1.0	48.5	132.6	2.53	1.70	1.310	100	1.25	153.1	0.6	96.3	0.8	2669.1	2.75E-04	3.00E-04	0.030	4.56E-03	10.4	3.86E-03	0.00
50.0	1.0	49.5	132.6	2.60	1.74	1.334	100	1.25	153.1	0.6	95.1	0.8	2692.2	2.76E-04	3.00E-04	0.030	4.62E-03	10.4	3.92E-03	0.00

TOTAL SETTLEMENT = **1.73**

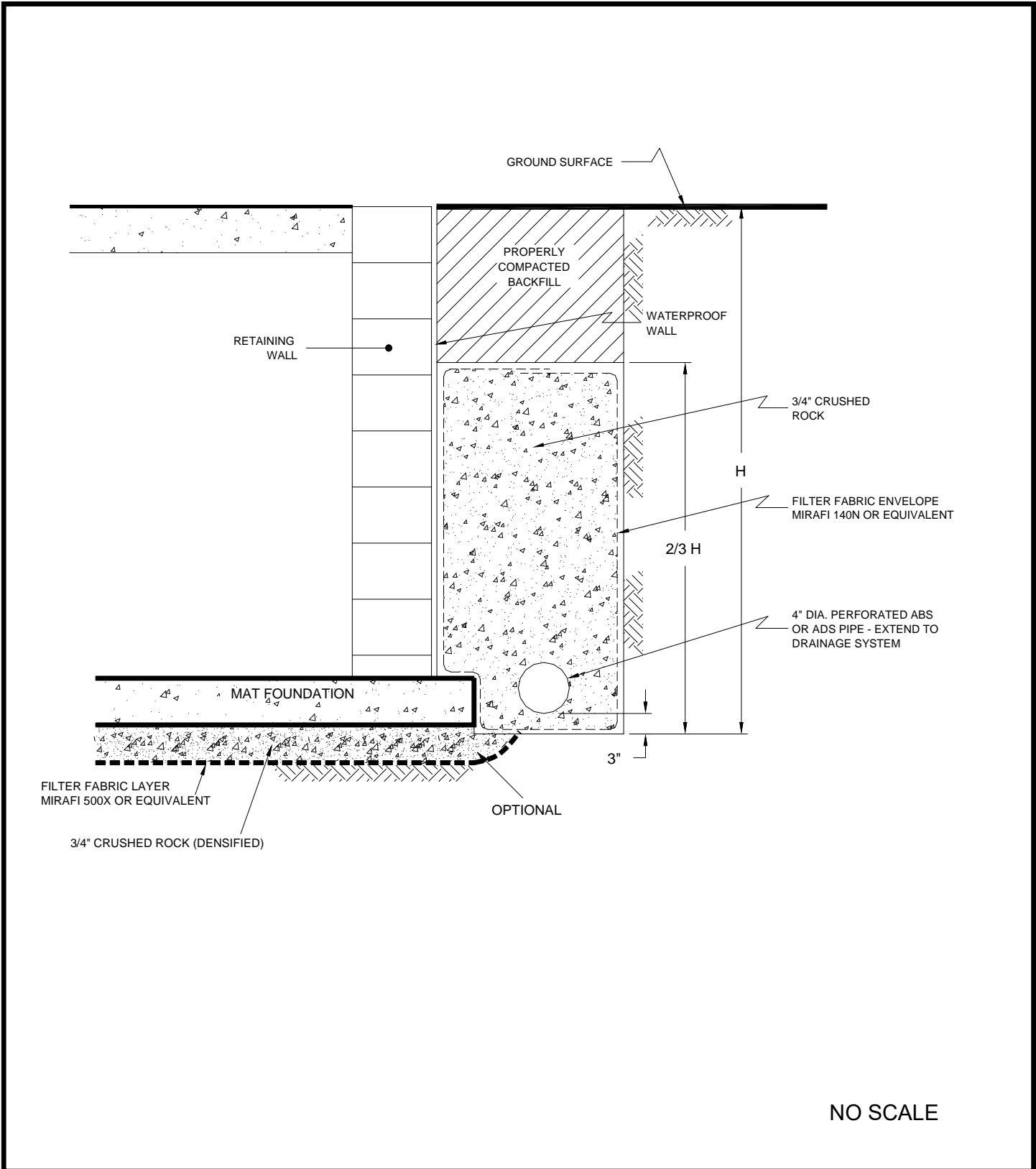

NO SCALE

GEOCON
WEST, INC.



ENVIRONMENTAL GEOTECHNICAL MATERIALS
3303 N. SAN FERNANDO BLVD. - SUITE 100 - BURBANK, CA 91504
PHONE (818) 841-8388 - FAX (818) 841-1704

DRAFTED BY: JJK	CHECKED BY: HHD
-----------------	-----------------

RETAINING WALL DRAIN DETAIL

910 SOUTH MARIPOSA STREET
BURBANK, CALIFORNIA

JAN. 2023	PROJECT NO. W1696-06-01	FIG. 17
-----------	-------------------------	---------

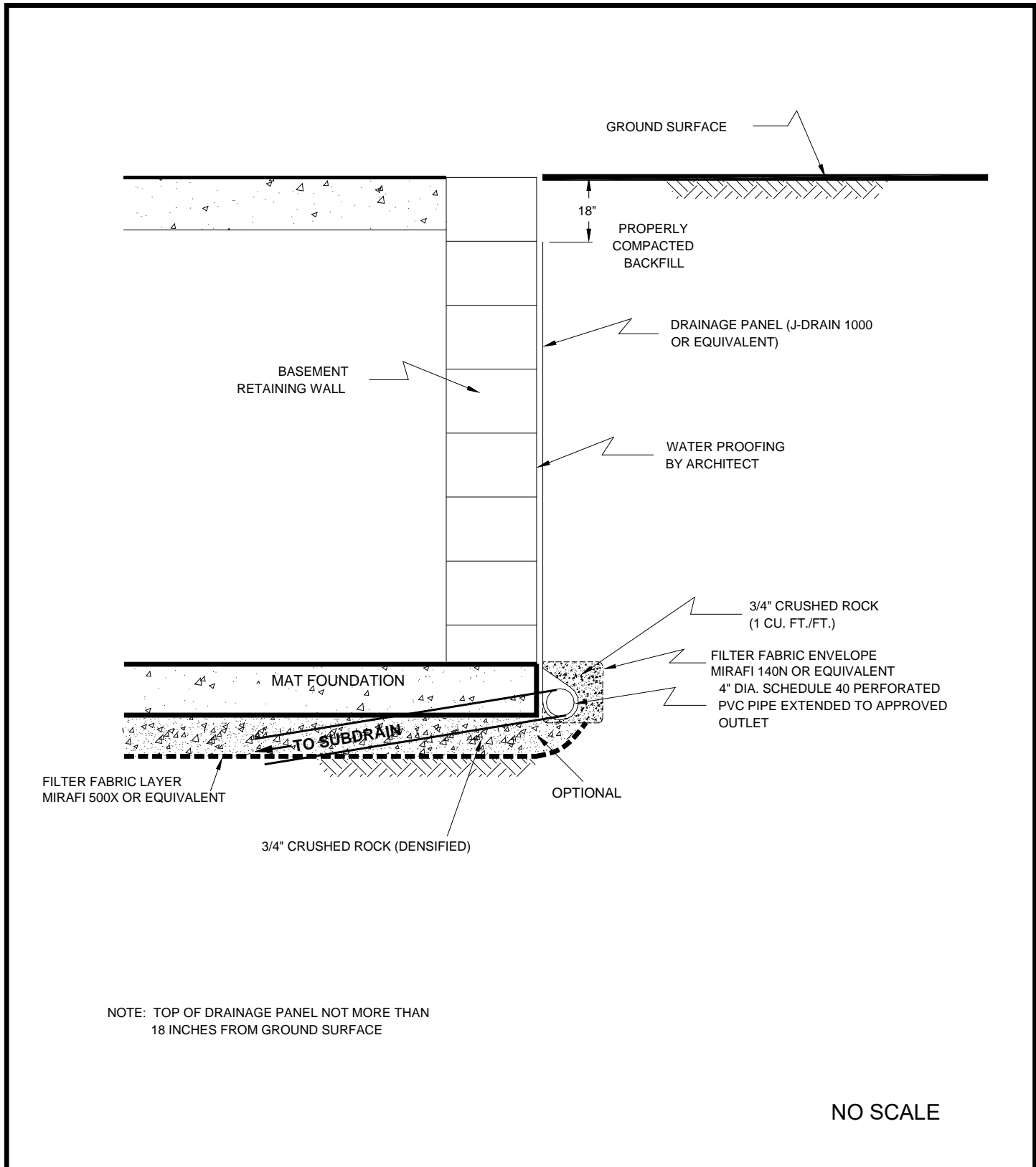

NOTE: TOP OF DRAINAGE PANEL NOT MORE THAN 18 INCHES FROM GROUND SURFACE

NO SCALE

GEOCON
WEST, INC.



ENVIRONMENTAL GEOTECHNICAL MATERIALS
3303 N. SAN FERNANDO BLVD. - SUITE 100 - BURBANK, CA 91504
PHONE (818) 841-8388 - FAX (818) 841-1704

DRAFTED BY: JJK	CHECKED BY: HHD
-----------------	-----------------

RETAINING WALL DRAIN DETAIL

910 SOUTH MARIPOSA STREET
BURBANK, CALIFORNIA

JAN. 2023	PROJECT NO. W1696-06-01	FIG. 18
-----------	-------------------------	---------

BORING PERCOLATION TEST FIELD LOG

Date: <u>Thursday, December 1, 2022</u>	Boring/Test Number: <u>B2</u>
Project Number: <u>W1696-06-01</u>	Diameter of Boring: <u>8</u> inches
Project Location: <u>910 S. Mariposa St</u>	Diameter of Casing: <u>2</u> inches
Earth Description: <u>SM</u>	Depth of Boring: <u>30</u> feet
Tested By: <u>MR</u>	Depth to Invert of BMP: <u>20</u> feet
Liquid Description: <u>Water</u>	Depth to Water Table: <u>>60</u> feet
Measurement Method: <u>Sounder</u>	Depth to Initial Water Depth (d₁): <u>180</u> inches
Start Time for Pre-Soak: <u>9:30 AM</u>	Water Remaining in Boring (Y/N): <u>No</u>
Start Time for Standard: <u>10:30 AM</u>	Standard Time Interval Between Readings: <u>10 min</u>

Reading Number	Time Start (hh:mm)	Time End (hh:mm)	Elapsed Time Δtime (min)	Water Drop During Standard Time Interval, Δd (in)	Soil Description Notes Comments
1	10:30 AM	10:40 AM	10	109.4	
2	11:00 AM	11:10 AM	10	112.4	
3	11:30 AM	11:40 AM	10	109.1	
4	12:00 PM	12:10 PM	10	111.4	
5	12:30 PM	12:40 PM	10	109.3	
6	1:00 PM	1:10 PM	10	108.5	Stabilized Readings
7	1:30 PM	1:40 PM	10	107.6	Achieved with Readings
8	2:00 PM	2:10 PM	10	107.9	6, 7, and 8

MEASURED PERCOLATION RATE & DESIGN INFILTRATION RATE CALCULATIONS*

* Calculations Below Based on Stabilized Readings Only

Boring Radius, r: 4 inches
 Test Section Height, h: 120.0 inches

Test Section Surface Area, $A = 2\pi rh + \pi r^2$
 $A =$ 3066 in²

Discharged Water Volume, $V = \pi r^2 \Delta d$

Percolation Rate = $\left(\frac{V/A}{\Delta T}\right)$

Reading 6 V = 5453 in³
 Reading 7 V = 5411 in³
 Reading 8 V = 5423 in³

Percolation Rate = 10.67 inches/hour
 Percolation Rate = 10.59 inches/hour
 Percolation Rate = 10.61 inches/hour

Measured Percolation Rate = 10.62 inches/hour

Reduction Factors

Small Diameter Boring, $RF_t =$ 1
 Site Variability, $RF_v =$ 1
 Long Term Siltation, $RF_s =$ 1

Total Reduction Factor, $RF = RF_t + RF_v + RF_s$
 Total Reduction Factor = 3

Design Infiltration Rate

Design Infiltration Rate = Measured Percolation Rate / RF

Design Infiltration Rate = 3.54 inches/hour

FIGURE 19

APPENDIX

A

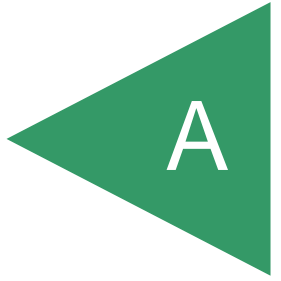

APPENDIX A

FIELD INVESTIGATION







The site was explored on December 1, 2022, by excavating three 7-inch diameter borings to a maximum depth of approximately 55½ feet below the existing ground surface using utilizing a truck-mounted hollow-stem auger drilling machine and two 3½ inch diameter borings to a maximum depth of 15½ feet below the ground surface using manual auger equipment. Representative and relatively undisturbed samples were obtained by driving a 3-inch, O. D., California Modified Sampler into the “undisturbed” soil mass with blows from a 140-pound auto-hammer falling 30 inches truck-mounted auger borings and with blows from a slide hammer for the manual auger borings. The California Modified Sampler was equipped with 1-inch by 2³/₈-inch diameter brass sampler rings to facilitate soil removal and testing. Bulk samples were obtained. Standard Penetration Tests were performed in borings B1 and B2.

The soil conditions encountered in the borings were visually examined, classified and logged in general accordance with the Unified Soil Classification System (USCS). The logs of the borings are presented on Figures A1 through A5. The logs depict the soil and geologic conditions encountered and the depth at which samples were obtained. The logs also include our interpretation of the conditions between sampling intervals. Therefore, the logs contain both observed and interpreted data. We determined the lines designating the interface between soil materials on the logs using visual observations, penetration rates, excavation characteristics and other factors. The transition between materials may be abrupt or gradual. Where applicable, the logs were revised based on subsequent laboratory testing. The locations of the borings are shown on Figure 2.

DEPTH IN FEET	SAMPLE NO.	LITHOLOGY	GROUNDWATER	SOIL CLASS (USCS)	BORING 1		PENETRATION RESISTANCE (BLOWS/FT*)	DRY DENSITY (P.C.F.)	MOISTURE CONTENT (%)
					ELEV. (MSL.) --	DATE COMPLETED <u>12/01/2022</u>			
					EQUIPMENT <u>HOLLOW STEM AUGER</u> BY: <u>JJK</u>				
MATERIAL DESCRIPTION									
0					ARTIFICIAL FILL Sandy Silt, soft, slightly moist, olive brown, fine-grained.				
2	B1@2'						9	90.5	3.3
4					ALLUVIUM Sandy Silt, soft, slightly moist, olive brown, fine-grained.				
6	B1@5'			ML	- trace medium-grained sand		4		
8	B1@7.5'				- stiff		25	97.7	2.5
10	B1@10'			SM	Silty Sand, loose, slightly moist, light gray with reddish brown oxidation staining, fine-grained.		9		
12	B1@12.5'			ML	Sandy Silt, stiff, slightly moist, olive gray and light reddish brown, fine-grained.		28	93.1	7.0
14	B1@14.5'				Silty Sand, firm, slightly moist, olive gray with light reddish brown oxidation stains, fine-grained.		12		
16				SM					
18	B1@17.5'						20	80.1	24.0
20	B1@19.5'			SP-SM	Sand with Silt, poorly graded, loose, slightly moist, light gray with light reddish brown oxidation stains, fine-grained.		10		
22	B1@22.5'				Sand, poorly graded, medium dense, slightly moist, light gray with light reddish brown oxidation, fine-grained, trace coarse-grained.		59	112.5	2.4
24									
26	B1@25'			SP	- no coarse-grained		25		
					- very dense, gray, trace medium- to coarse-grained				
28	B1@27.5'						50 (4")	118.8	2.0

Figure A1,
Log of Boring 1, Page 1 of 2

W1696-06-01 BORING LOGS.GPJ

SAMPLE SYMBOLS	 ... SAMPLING UNSUCCESSFUL	 ... STANDARD PENETRATION TEST	 ... DRIVE SAMPLE (UNDISTURBED)
	 ... DISTURBED OR BAG SAMPLE	 ... CHUNK SAMPLE	 ... WATER TABLE OR SEEPAGE

NOTE: THE LOG OF SUBSURFACE CONDITIONS SHOWN HEREON APPLIES ONLY AT THE SPECIFIC BORING OR TRENCH LOCATION AND AT THE DATE INDICATED. IT IS NOT WARRANTED TO BE REPRESENTATIVE OF SUBSURFACE CONDITIONS AT OTHER LOCATIONS AND TIMES.

DEPTH IN FEET	SAMPLE NO.	LITHOLOGY	GROUNDWATER	SOIL CLASS (USCS)	BORING 1			PENETRATION RESISTANCE (BLOWS/FT*)	DRY DENSITY (P.C.F.)	MOISTURE CONTENT (%)
					ELEV. (MSL.)	DATE COMPLETED				
					ELEV. (MSL.) --	DATE COMPLETED <u>12/01/2022</u>				
					EQUIPMENT <u>HOLLOW STEM AUGER</u> BY: <u>JKJ</u>					
					MATERIAL DESCRIPTION					
30	B1@30'			SP	- some medium- to coarse-grained, trace fine gravel			50 (4")		
32	B1@32.5'		- increase in coarse-grained, trace medium-grained and fine gravel			50 (5")	116.0	2.2		
34										
36	B1@35'		- decrease in coarse-grained, increase in fine-grained			50 (6")				
38	B1@37.5'		- increase in medium-grained, trace coarse-grained and fine gravel			50 (4")	101.9	2.1		
40	B1@40'		- no recovery			50 (6")				
42	B1@42.5'		- no recovery			50 (4")				
44										
	B1@45'				Total depth of boring: 45.5 feet Fill to 3 feet. No groundwater encountered. Backfilled with soil cuttings and tamped. *Penetration resistance for 140-pound hammer falling 30 inches by auto-hammer. NOTE: The stratification lines presented herein represent the approximate boundary between earth types; the transitions may be gradual.			50 (1")		

Figure A1,
Log of Boring 1, Page 2 of 2

W1696-06-01 BORING LOGS.GPJ







SAMPLE SYMBOLS	... SAMPLING UNSUCCESSFUL	... STANDARD PENETRATION TEST	... DRIVE SAMPLE (UNDISTURBED)
	... DISTURBED OR BAG SAMPLE	... CHUNK SAMPLE	... WATER TABLE OR SEEPAGE

NOTE: THE LOG OF SUBSURFACE CONDITIONS SHOWN HEREON APPLIES ONLY AT THE SPECIFIC BORING OR TRENCH LOCATION AND AT THE DATE INDICATED. IT IS NOT WARRANTED TO BE REPRESENTATIVE OF SUBSURFACE CONDITIONS AT OTHER LOCATIONS AND TIMES.

DEPTH IN FEET	SAMPLE NO.	LITHOLOGY	GROUNDWATER	SOIL CLASS (USCS)	BORING 2		PENETRATION RESISTANCE (BLOWS/FT*)	DRY DENSITY (P.C.F.)	MOISTURE CONTENT (%)
					ELEV. (MSL.) --	DATE COMPLETED <u>12/01/2022</u>			
					EQUIPMENT <u>HOLLOW STEM AUGER</u> BY: <u>JJK</u>				
MATERIAL DESCRIPTION									
0						ARTIFICIAL FILL Sandy Silt, firm, slightly moist, olive brown.			
2	B2@2.5'					- loose, fine-grained, no recovery	9		
4	B2@4'			ML		ALLUVIUM Sandy Silt, soft, slightly moist to moist, olive gray.	4		
6									
8	B2@7.5'					- brown	22	74.5	14.5
10	B2@10'			SP-SM		Sand with Silt, poorly graded, loose, slightly moist, gray with reddish brown oxidation stains, fine-grained.	7	76.3	4.0
12	B2@12'			ML		Silt with Sand, firm, slightly moist, olive brown with reddish brown oxidation staining, fine-grained.	9		
14									
16	B2@15'			ML		- stiff Sandy Silt, very soft, moist, dark gray.	23	92.0	4.8
18	B2@17.5'						2		
20	B2@20'			SM		Silty Sand, very loose, slightly moist, gray and reddish brown, fine-grained.	22	102.7	4.2
22				ML		Silt, stiff, moist, dark olive brown with oxidation staining.			
24	B2@22.5'					Sand, poorly graded, medium dense, slightly moist, gray with reddish brown oxidation staining, fine-grained, some medium gravel, trace coarse-grained.	24		
26	B2@25'			SP		- very dense, gray and olive gray, no medium- to coarse-grained	50 (6")	110.6	3.1
28	B2@27.5'					- medium dense, light gray with reddish brown staining, some medium-grained, trace coarse-grained and fine gravel	49		

Figure A2,
Log of Boring 2, Page 1 of 3

W1696-06-01 BORING LOGS.GPJ

SAMPLE SYMBOLS	 ... SAMPLING UNSUCCESSFUL	 ... STANDARD PENETRATION TEST	 ... DRIVE SAMPLE (UNDISTURBED)
	 ... DISTURBED OR BAG SAMPLE	 ... CHUNK SAMPLE	 ... WATER TABLE OR SEEPAGE

NOTE: THE LOG OF SUBSURFACE CONDITIONS SHOWN HEREON APPLIES ONLY AT THE SPECIFIC BORING OR TRENCH LOCATION AND AT THE DATE INDICATED. IT IS NOT WARRANTED TO BE REPRESENTATIVE OF SUBSURFACE CONDITIONS AT OTHER LOCATIONS AND TIMES.

DEPTH IN FEET	SAMPLE NO.	LITHOLOGY	GROUNDWATER	SOIL CLASS (USCS)	BORING 2		PENETRATION RESISTANCE (BLOWS/FT*)	DRY DENSITY (P.C.F.)	MOISTURE CONTENT (%)
					ELEV. (MSL.) --	DATE COMPLETED <u>12/01/2022</u>			
					EQUIPMENT <u>HOLLOW STEM AUGER</u> BY: <u>JJK</u>				
MATERIAL DESCRIPTION									
30	B2@30'			SP	- slightly moist to moist, dark gray, fine-grained, some medium- to coarse-grained	74	117.4	2.8	
32	B2@32.5'			ML	- some fine to coarse gravel Silt, hard, moist, dark olive brown.	31			
34	B2@35'			SP	Sand, poorly graded, very dense, slightly moist, gray, fine-grained, trace coarse gravel.	50 (3")	102.3	2.8	
36	B2@37.5'			SP	Sand with Gravel, poorly graded, dense, slightly moist, gray, coarse-grained, fine gravel and medium-grained.	41			
38	B2@40'			SP	Sand, poorly graded, very dense, slightly moist, light gray, fine-grained.	50 (4")	106.3	3.1	
40	B2@42.5'			SP	- very dense, slightly moist to moist - some medium- to coarse-grained, fine gravel	65			
42	B2@45'			SW	Sand, well-graded, very dense, slightly moist to moist, gray, fine- to coarse-grained, some fine to coarse gravel.	50 (5")	130.8	1.3	
44	B2@47.5'			SW	- coarse gravel	50 (4")			
46	B2@50'			SW	- no recovery	50 (3")	107.4	2.3	
48	B2@55'			SW	- no recovery	50 (3")			
					Total depth of boring: 55.5 feet Fill to 3 feet. No groundwater encountered. Percolation testing performed. Backfilled with soil cuttings and tamped. *Penetration resistance for 140-pound hammer falling 30 inches by				

Figure A2,
Log of Boring 2, Page 2 of 3

W1696-06-01 BORING LOGS.GPJ

SAMPLE SYMBOLS		... SAMPLING UNSUCCESSFUL		... STANDARD PENETRATION TEST		... DRIVE SAMPLE (UNDISTURBED)
		... DISTURBED OR BAG SAMPLE		... CHUNK SAMPLE		... WATER TABLE OR SEEPAGE

NOTE: THE LOG OF SUBSURFACE CONDITIONS SHOWN HEREON APPLIES ONLY AT THE SPECIFIC BORING OR TRENCH LOCATION AND AT THE DATE INDICATED. IT IS NOT WARRANTED TO BE REPRESENTATIVE OF SUBSURFACE CONDITIONS AT OTHER LOCATIONS AND TIMES.

DEPTH IN FEET	SAMPLE NO.	LITHOLOGY	GROUNDWATER	SOIL CLASS (USCS)	BORING 2		PENETRATION RESISTANCE (BLOWS/FT*)	DRY DENSITY (P.C.F.)	MOISTURE CONTENT (%)	
					ELEV. (MSL.) --	DATE COMPLETED <u>12/01/2022</u>				
					EQUIPMENT <u>HOLLOW STEM AUGER</u> BY: <u>JJK</u>					
					MATERIAL DESCRIPTION					
					auto-hammer. NOTE: The stratification lines presented herein represent the approximate boundary between earth types; the transitions may be gradual.					

**Figure A2,
Log of Boring 2, Page 3 of 3**

W1696-06-01 BORING LOGS.GPJ







SAMPLE SYMBOLS	<input type="checkbox"/> ... SAMPLING UNSUCCESSFUL	<input type="checkbox"/> ... STANDARD PENETRATION TEST	<input type="checkbox"/> ... DRIVE SAMPLE (UNDISTURBED)
	<input checked="" type="checkbox"/> ... DISTURBED OR BAG SAMPLE	<input checked="" type="checkbox"/> ... CHUNK SAMPLE	<input checked="" type="checkbox"/> ... WATER TABLE OR SEEPAGE

NOTE: THE LOG OF SUBSURFACE CONDITIONS SHOWN HEREON APPLIES ONLY AT THE SPECIFIC BORING OR TRENCH LOCATION AND AT THE DATE INDICATED. IT IS NOT WARRANTED TO BE REPRESENTATIVE OF SUBSURFACE CONDITIONS AT OTHER LOCATIONS AND TIMES.

DEPTH IN FEET	SAMPLE NO.	LITHOLOGY	GROUNDWATER	SOIL CLASS (USCS)	BORING 3			PENETRATION RESISTANCE (BLOWS/FT*)	DRY DENSITY (P.C.F.)	MOISTURE CONTENT (%)
					ELEV. (MSL.)	DATE COMPLETED	BY:			
					ELEV. (MSL.) --	DATE COMPLETED 12/01/2022				
					EQUIPMENT HOLLOW STEM AUGER		BY: JJK			
MATERIAL DESCRIPTION										
0					ARTIFICIAL FILL Sandy Silt, firm, moist, olive brown.					
2	B3@2.5'				ALLUVIUM Sandy Silt, soft, slightly moist to moist, olive brown, fine-grained.			9	87.2	4.8
4	B3@5'			ML	- lense of dark grayish brown			9	90.0	19.9
6										
8	B3@7.5'				- firm, slightly moist, gray to olive gray			21	96.4	11.8
10	B3@10'			SM	Silty Sand, medium dense, slightly moist, light gray with slight reddish brown oxidation staining, fine-grained.			21	99.0	4.1
12										
14	B3@15'			ML	Sandy Silt, firm, slightly moist to moist, light gray with light reddish brown oxidation staining, fine-grained.			24	93.5	3.8
16										
18				ML	Silt with Sand, stiff, moist, olive brown with gray and reddish brown oxidation staining.					
20	B3@20'			SP-SM	Sand with Silt, poorly graded, medium dense, slightly moist, olive gray, fine-grained, trace medium- to coarse-grained.			31	105.1	5.1
					Total depth of boring: 20.5 feet Fill to 2 feet. No groundwater encountered. Backfilled with soil cuttings and tamped.					
					*Penetration resistance for 140-pound hammer falling 30 inches by auto-hammer. NOTE: The stratification lines presented herein represent the approximate boundary between earth types; the transitions may be gradual.					

Figure A3,
Log of Boring 3, Page 1 of 1

W1696-06-01 BORING LOGS.GPJ

SAMPLE SYMBOLS	 ... SAMPLING UNSUCCESSFUL	 ... STANDARD PENETRATION TEST	 ... DRIVE SAMPLE (UNDISTURBED)
	 ... DISTURBED OR BAG SAMPLE	 ... CHUNK SAMPLE	 ... WATER TABLE OR SEEPAGE

NOTE: THE LOG OF SUBSURFACE CONDITIONS SHOWN HEREON APPLIES ONLY AT THE SPECIFIC BORING OR TRENCH LOCATION AND AT THE DATE INDICATED. IT IS NOT WARRANTED TO BE REPRESENTATIVE OF SUBSURFACE CONDITIONS AT OTHER LOCATIONS AND TIMES.











DEPTH IN FEET	SAMPLE NO.	LITHOLOGY	GROUNDWATER	SOIL CLASS (USCS)	BORING 4		PENETRATION RESISTANCE (BLOWS/FT*)	DRY DENSITY (P.C.F.)	MOISTURE CONTENT (%)
					ELEV. (MSL.) --	DATE COMPLETED <u>12/01/2022</u>			
					EQUIPMENT <u>HAND AUGER</u> BY: <u>JJK</u>				
MATERIAL DESCRIPTION									
0	BULK 0-4.5'								
2									
4	B4@3'						84.8	20.3	
6	B4@6'								
8				SP-SM					
10	B4@10'						91.1	7.6	
					- increase in sand and oxidation			92.2	4.1
					Total depth of boring: 10.5 feet Fill to 5 feet. No groundwater encountered. Backfilled with soil cuttings and tamped.				
					NOTE: The stratification lines presented herein represent the approximate boundary between earth types; the transitions may be gradual.				

Figure A4,
Log of Boring 4, Page 1 of 1

W1696-06-01 BORING LOGS.GPJ

SAMPLE SYMBOLS	 ... SAMPLING UNSUCCESSFUL	 ... STANDARD PENETRATION TEST	 ... DRIVE SAMPLE (UNDISTURBED)
	 ... DISTURBED OR BAG SAMPLE	 ... CHUNK SAMPLE	 ... WATER TABLE OR SEEPAGE

NOTE: THE LOG OF SUBSURFACE CONDITIONS SHOWN HEREON APPLIES ONLY AT THE SPECIFIC BORING OR TRENCH LOCATION AND AT THE DATE INDICATED. IT IS NOT WARRANTED TO BE REPRESENTATIVE OF SUBSURFACE CONDITIONS AT OTHER LOCATIONS AND TIMES.

DEPTH IN FEET	SAMPLE NO.	LITHOLOGY	GROUNDWATER	SOIL CLASS (USCS)	BORING 5		PENETRATION RESISTANCE (BLOWS/FT*)	DRY DENSITY (P.C.F.)	MOISTURE CONTENT (%)
					ELEV. (MSL.) --	DATE COMPLETED <u>12/01/2022</u>			
					EQUIPMENT <u>HAND AUGER</u> BY: <u>JJK</u>				
MATERIAL DESCRIPTION									
0	BULK 0-5'					ARTIFICIAL FILL Silty Sand, poorly graded, loose, slightly moist, yellowish brown, fine-grained, trace medium- to coarse-grained.			
2	B5@3'						- medium dense, brown, roots and rootlets, trace fine gravel	82.8	12.9
4	B5@5.5'							108.6	7.7
6					SM	ALLUVIUM Silty Sand, poorly graded, medium dense, slightly moist, gray and light olive brown, fine-grained, root, trace rootlets.			
8							- coarse gravel		
10	B5@9.5'						- light olive brown and gray with oxidation mottles - olive brown	95.1	6.5
12	B5@12'								
14	B5@15'					- gray to olive brown with oxidation, trace roots	89.4	6.7	
Total depth of boring: 15.5 feet Fill to 9 feet. No groundwater encountered. Backfilled with soil cuttings and tamped.									
NOTE: The stratification lines presented herein represent the approximate boundary between earth types; the transitions may be gradual.									
							91.2	13.9	

Figure A5,
Log of Boring 5, Page 1 of 1

W1696-06-01 BORING LOGS.GPJ

SAMPLE SYMBOLS	... SAMPLING UNSUCCESSFUL	... STANDARD PENETRATION TEST	... DRIVE SAMPLE (UNDISTURBED)
	... DISTURBED OR BAG SAMPLE	... CHUNK SAMPLE	... WATER TABLE OR SEEPAGE

NOTE: THE LOG OF SUBSURFACE CONDITIONS SHOWN HEREON APPLIES ONLY AT THE SPECIFIC BORING OR TRENCH LOCATION AND AT THE DATE INDICATED. IT IS NOT WARRANTED TO BE REPRESENTATIVE OF SUBSURFACE CONDITIONS AT OTHER LOCATIONS AND TIMES.

APPENDIX

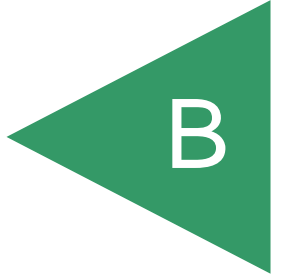

APPENDIX B

LABORATORY TESTING

Laboratory tests were performed in accordance with generally accepted test methods of the International ASTM, or other suggested procedures. Selected samples were tested for direct shear strength, grain size, consolidation and expansion characteristics, corrosivity, in-place dry density and moisture content. The results of the laboratory tests are summarized in Figures B1 through B29. The in-place dry density and moisture content of the samples tested are presented on the boring logs, Appendix A.

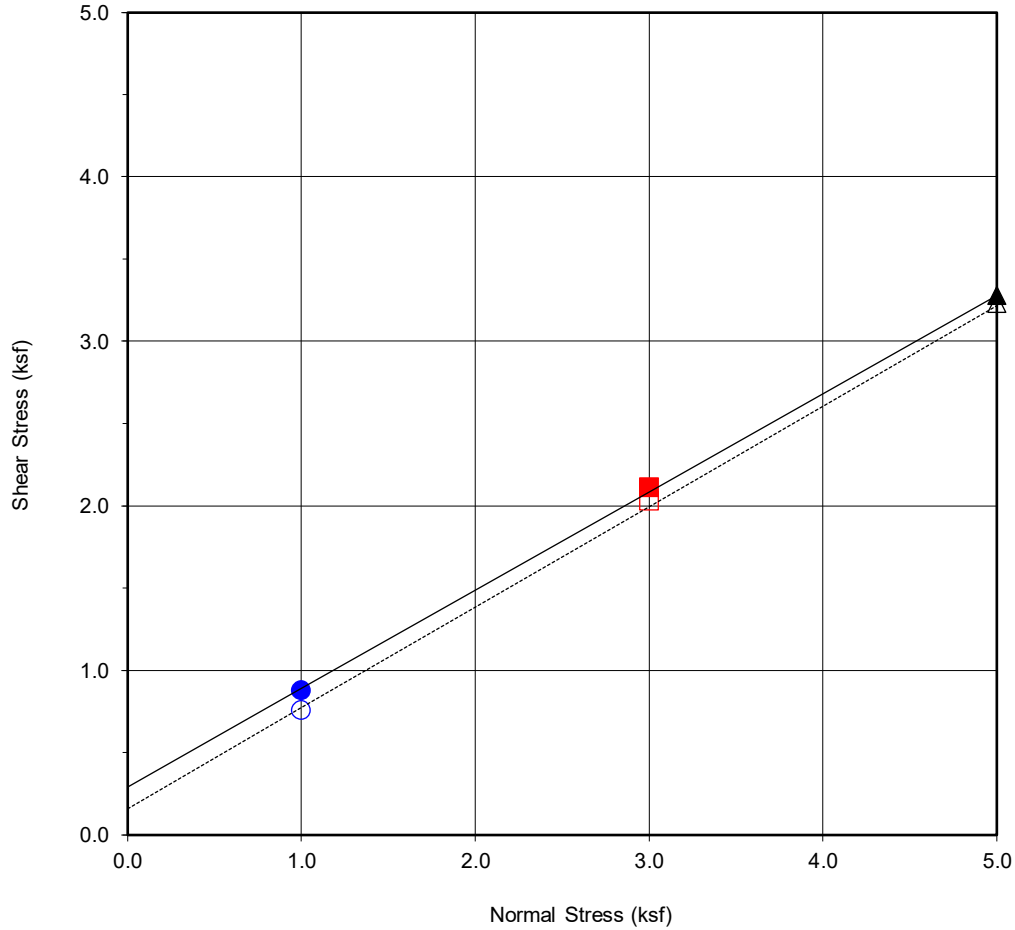

Boring No.	B1
Sample No.	B1@0-5'
Depth (ft)	0-5
<u>Sample Type:</u>	Bulk

<u>Soil Identification:</u>		
Sandy Silt (ML)		
Strength Parameters		
	C (psf)	ϕ ($^{\circ}$)
Peak	293	31
Ultimate	162	31

Normal Stress (kip/ft ²)	1	3	5
Peak Shear Stress (kip/ft ²)	● 0.88	■ 2.11	▲ 3.26
Shear Stress @ End of Test (ksf)	○ 0.76	□ 2.03	△ 3.20
Deformation Rate (in./min.)	0.05	0.05	0.05
Initial Sample Height (in.)	1.0	1.0	1.0
Ring Inside Diameter (in.)	2.375	2.375	2.375
Initial Moisture Content (%)	32.7	18.4	19.9
Initial Dry Density (pcf)	79.7	87.3	90.2
Initial Degree of Saturation (%)	79.1	53.4	61.9
Soil Height Before Shearing (in.)	1.2	1.2	1.2
Final Moisture Content (%)	39.4	29.1	25.7



DIRECT SHEAR TEST RESULTS
Consolidated Drained ASTM D-3080

Checked by: JJK

Project No.: W1696-06-01
910 SOUTH MARIPOSA STREET
BURBANK, CALIFORNIA
JAN. 2023 Figure B1

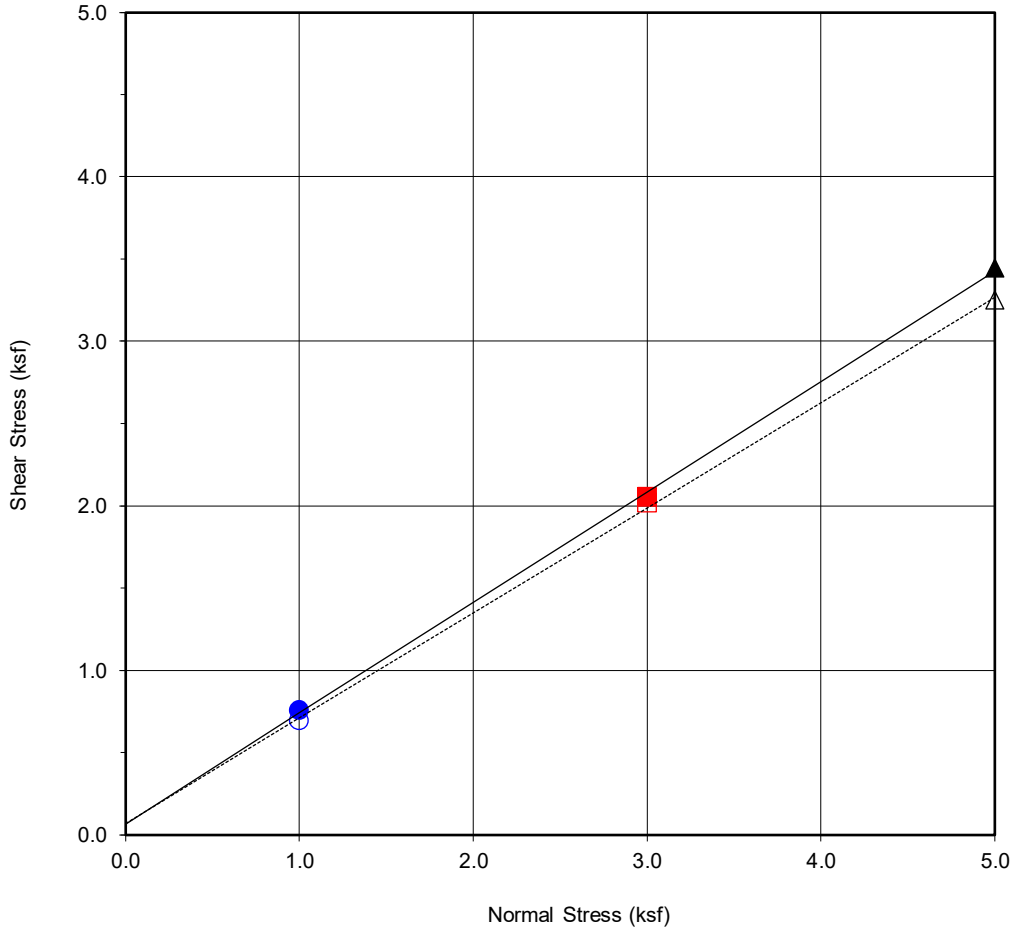

Boring No.	B3
Sample No.	B3@5'
Depth (ft)	5
<u>Sample Type:</u>	Ring

<u>Soil Identification:</u>		
Sandy Silt (ML)		
Strength Parameters		
	C (psf)	ϕ ($^{\circ}$)
Peak	68	34
Ultimate	71	33

Normal Stress (kip/ft ²)	1	3	5
Peak Shear Stress (kip/ft ²)	● 0.76	■ 2.05	▲ 3.44
Shear Stress @ End of Test (ksf)	○ 0.70	□ 2.02	△ 3.25
Deformation Rate (in./min.)	0.05	0.05	0.05
Initial Sample Height (in.)	1.0	1.0	1.0
Ring Inside Diameter (in.)	2.375	2.375	2.375
Initial Moisture Content (%)	32.7	18.4	19.9
Initial Dry Density (pcf)	79.7	87.3	90.2
Initial Degree of Saturation (%)	79.1	53.4	61.9
Soil Height Before Shearing (in.)	1.2	1.2	1.2
Final Moisture Content (%)	39.4	29.1	25.7



DIRECT SHEAR TEST RESULTS
Consolidated Drained ASTM D-3080

Checked by: JJK

Project No.: W1696-06-01
910 SOUTH MARIPOSA STREET
BURBANK, CALIFORNIA
JAN. 2023 Figure B2

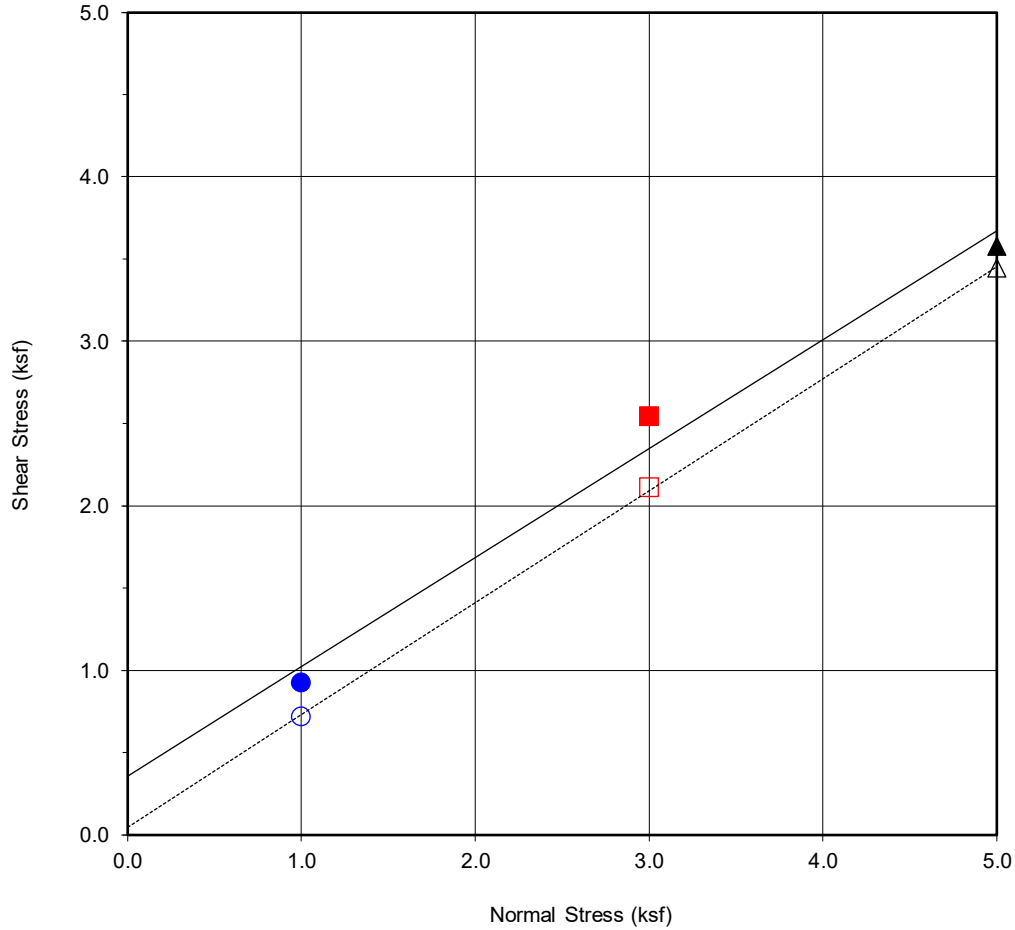

Boring No.	B4
Sample No.	B4@6'
Depth (ft)	6
Sample Type:	Ring

Soil Identification:		
Sand w/ Silt (SP-SM)		
Strength Parameters		
	C (psf)	ϕ ($^{\circ}$)
Peak	359	34
Ultimate	49	34

Normal Stress (kip/ft ²)	1	3	5
Peak Shear Stress (kip/ft ²)	● 0.92	■ 2.54	▲ 3.58
Shear Stress @ End of Test (ksf)	○ 0.72	□ 2.11	△ 3.44
Deformation Rate (in./min.)	0.05	0.05	0.05
Initial Sample Height (in.)	1.0	1.0	1.0
Ring Inside Diameter (in.)	2.375	2.375	2.375
Initial Moisture Content (%)	6.0	6.3	7.6
Initial Dry Density (pcf)	91.3	89.8	93.2
Initial Degree of Saturation (%)	19.2	19.5	25.2
Soil Height Before Shearing (in.)	1.2	1.2	1.2
Final Moisture Content (%)	26.2	26.3	26.2



DIRECT SHEAR TEST RESULTS
Consolidated Drained ASTM D-3080

Checked by: JJK

Project No.: W1696-06-01
910 SOUTH MARIPOSA STREET
BURBANK, CALIFORNIA
JAN. 2023 Figure B3

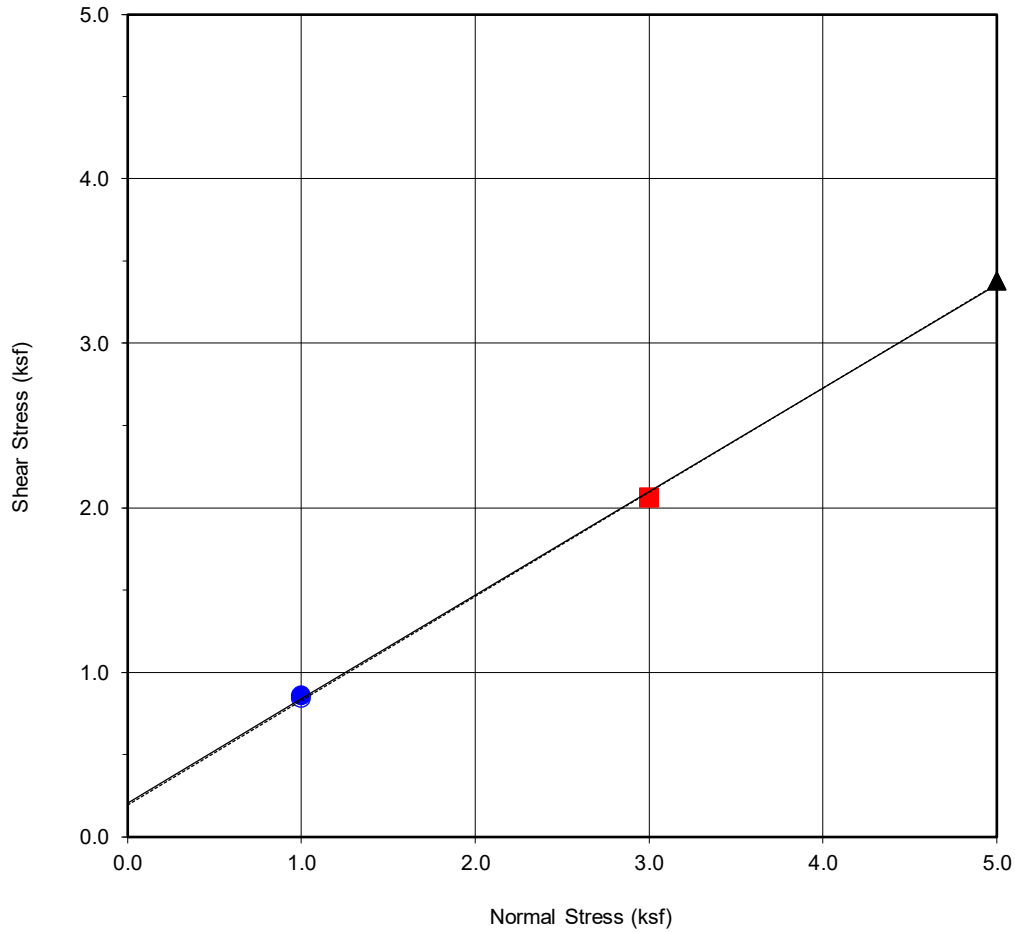

Boring No.	B5
Sample No.	B5@3'
Depth (ft)	3
<u>Sample Type:</u>	Ring

<u>Soil Identification:</u>		
Silty Sand (SM)		
Strength Parameters		
	C (psf)	ϕ ($^{\circ}$)
Peak	208	32
Ultimate	194	32

Normal Stress (kip/ft ²)	1	3	5
Peak Shear Stress (kip/ft ²)	● 0.86	■ 2.06	▲ 3.38
Shear Stress @ End of Test (ksf)	○ 0.84	□ 2.06	△ 3.38
Deformation Rate (in./min.)	0.05	0.05	0.05
Initial Sample Height (in.)	1.0	1.0	1.0
Ring Inside Diameter (in.)	2.375	2.375	2.375
Initial Moisture Content (%)	13.3	13.5	12.9
Initial Dry Density (pcf)	78.1	82.9	87.8
Initial Degree of Saturation (%)	31.1	35.2	38.0
Soil Height Before Shearing (in.)	1.2	1.2	1.2
Final Moisture Content (%)	28.5	25.0	22.9



DIRECT SHEAR TEST RESULTS

Consolidated Drained ASTM D-3080

Checked by: JJK

Project No.: W1696-06-01

910 SOUTH MARIPOSA STREET
BURBANK, CALIFORNIA

JAN. 2023

Figure B4

WATER ADDED AT 2.0 KSF

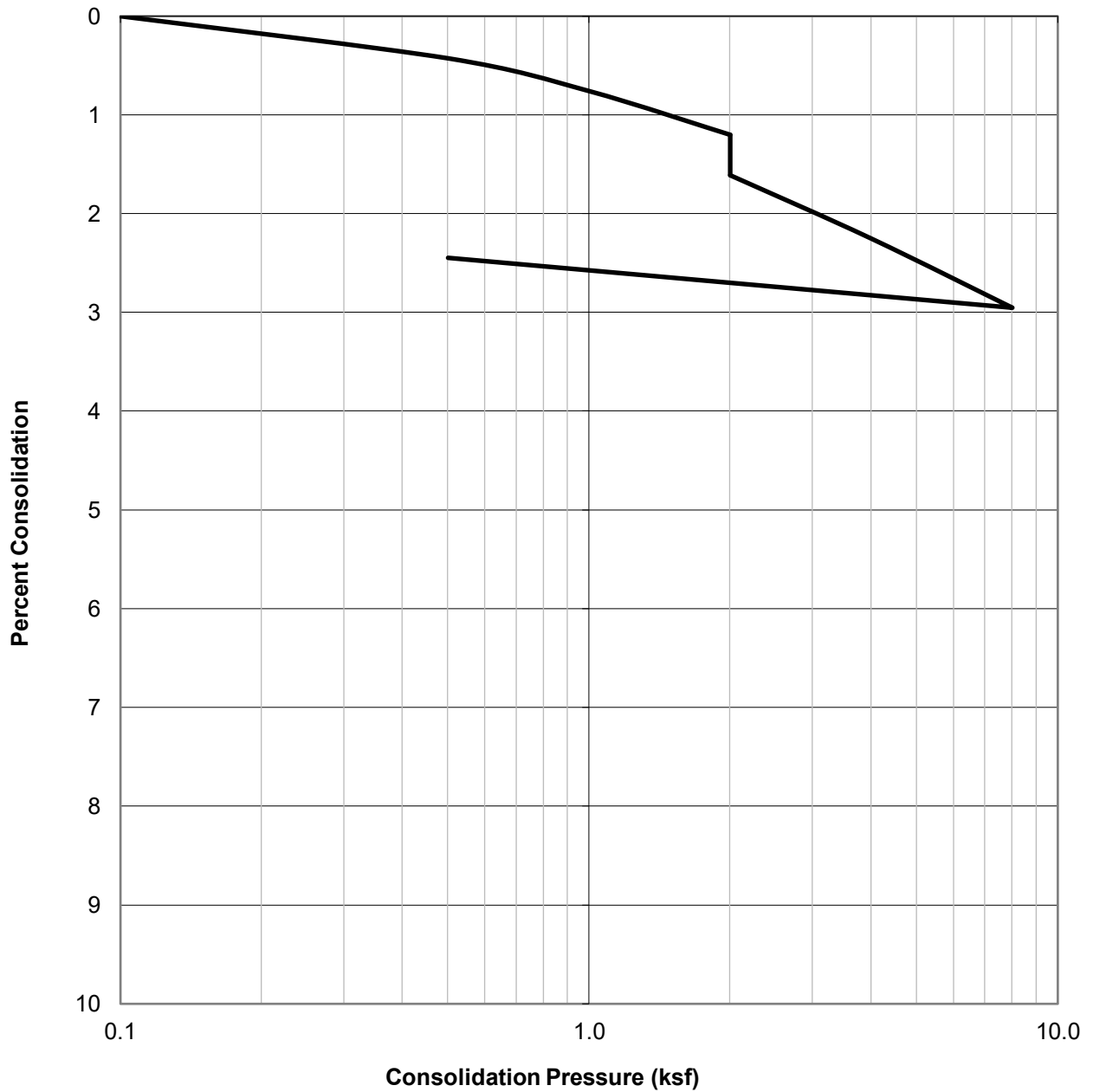

SAMPLE ID.	SOIL TYPE	DRY DENSITY (PCF)	INITIAL MOISTURE (%)	FINAL MOISTURE (%)
B1@7.5	Sandy Silt (ML)	94.1	2.5	23.6



CONSOLIDATION TEST RESULTS

ASTM D-2435

Checked by: JJK

Project No.: W1696-06-01

910 SOUTH MARIPOSA STREET
BURBANK, CALIFORNIA

JAN. 2023

Figure B5

WATER ADDED AT 2.0 KSF

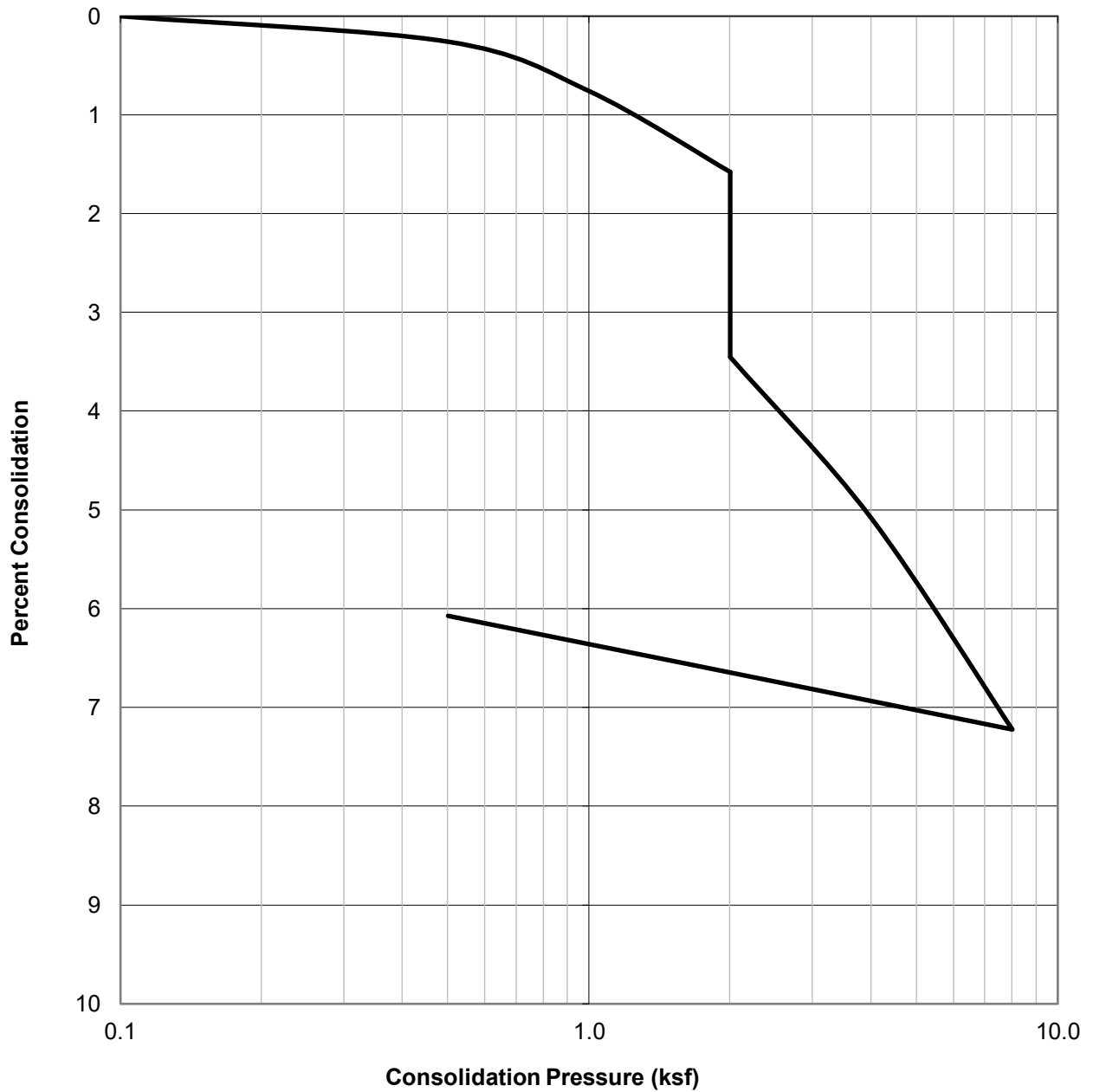

SAMPLE ID.	SOIL TYPE	DRY DENSITY (PCF)	INITIAL MOISTURE (%)	FINAL MOISTURE (%)
B1@12.5	Sandy Silt (ML)	82.0	7.0	31.9

	CONSOLIDATION TEST RESULTS ASTM D-2435	Project No.: W1696-06-01
	Checked by: JJK	910 SOUTH MARIPOSA STREET BURBANK, CALIFORNIA
		JAN. 2023 Figure B6

WATER ADDED AT 2.0 KSF

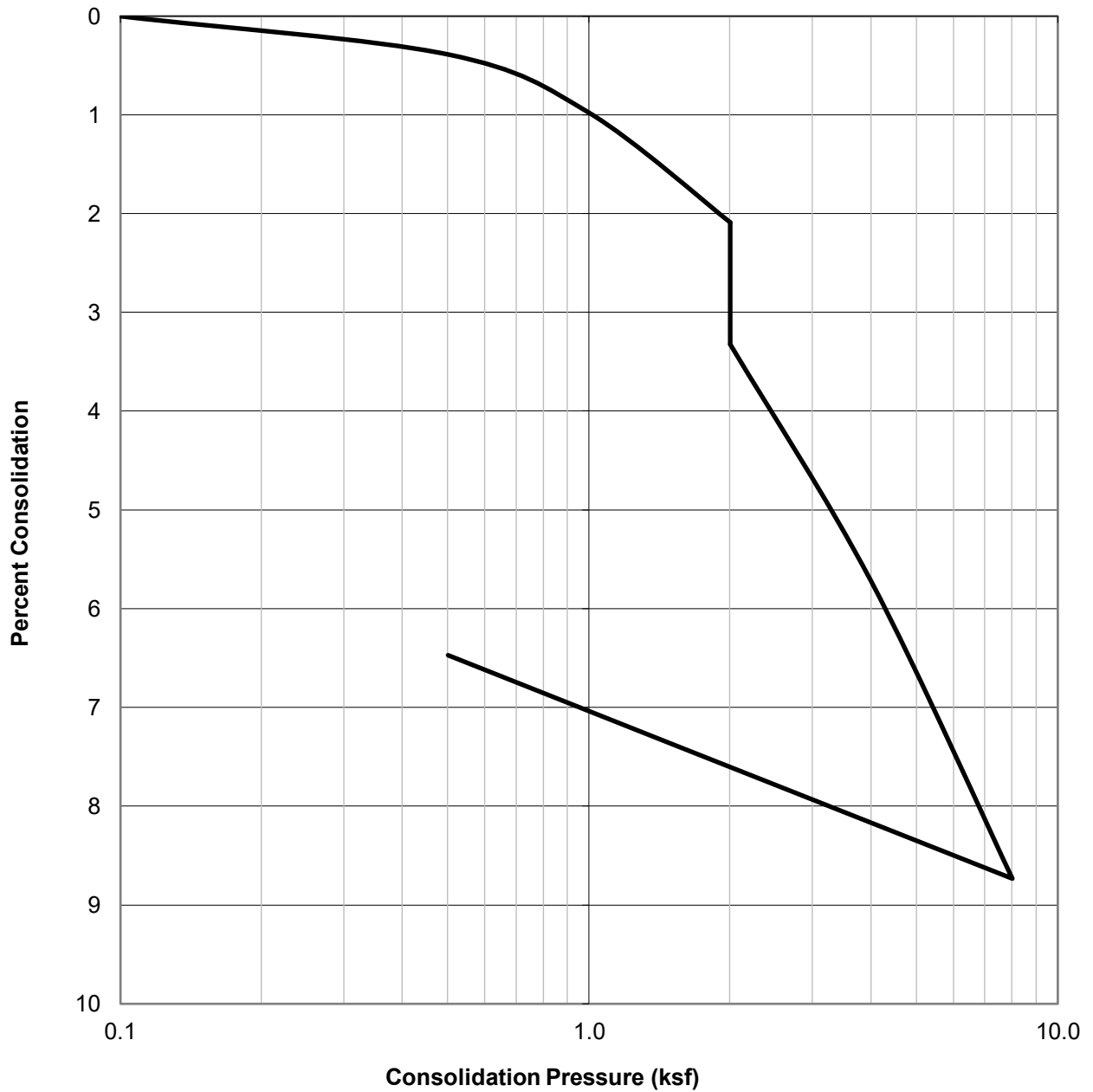

SAMPLE ID.	SOIL TYPE	DRY DENSITY (PCF)	INITIAL MOISTURE (%)	FINAL MOISTURE (%)
B1@17.5	Silty Sand (SM)	76.4	17.0	37.5



CONSOLIDATION TEST RESULTS

ASTM D-2435

Checked by: JJK

Project No.: W1696-06-01

910 SOUTH MARIPOSA STREET
BURBANK, CALIFORNIA

JAN. 2023

Figure B7

WATER ADDED AT 2.0 KSF

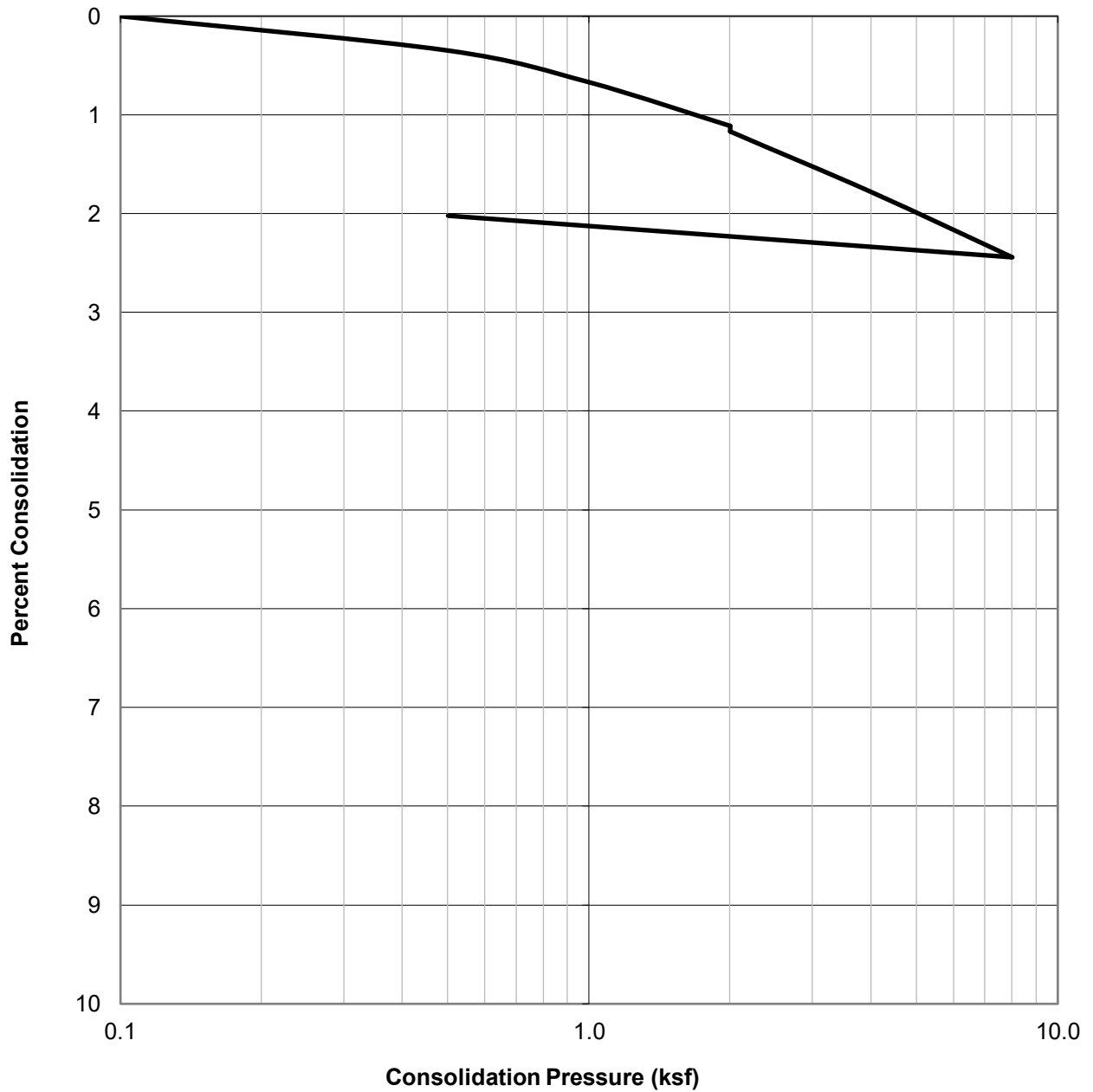

SAMPLE ID.	SOIL TYPE	DRY DENSITY (PCF)	INITIAL MOISTURE (%)	FINAL MOISTURE (%)
B1@22.5	Sand (SP)	109.3	2.4	17.7

	CONSOLIDATION TEST RESULTS ASTM D-2435	Project No.: W1696-06-01
		910 SOUTH MARIPOSA STREET BURBANK, CALIFORNIA
	Checked by: JJK	JAN. 2023

WATER ADDED AT 2.0 KSF

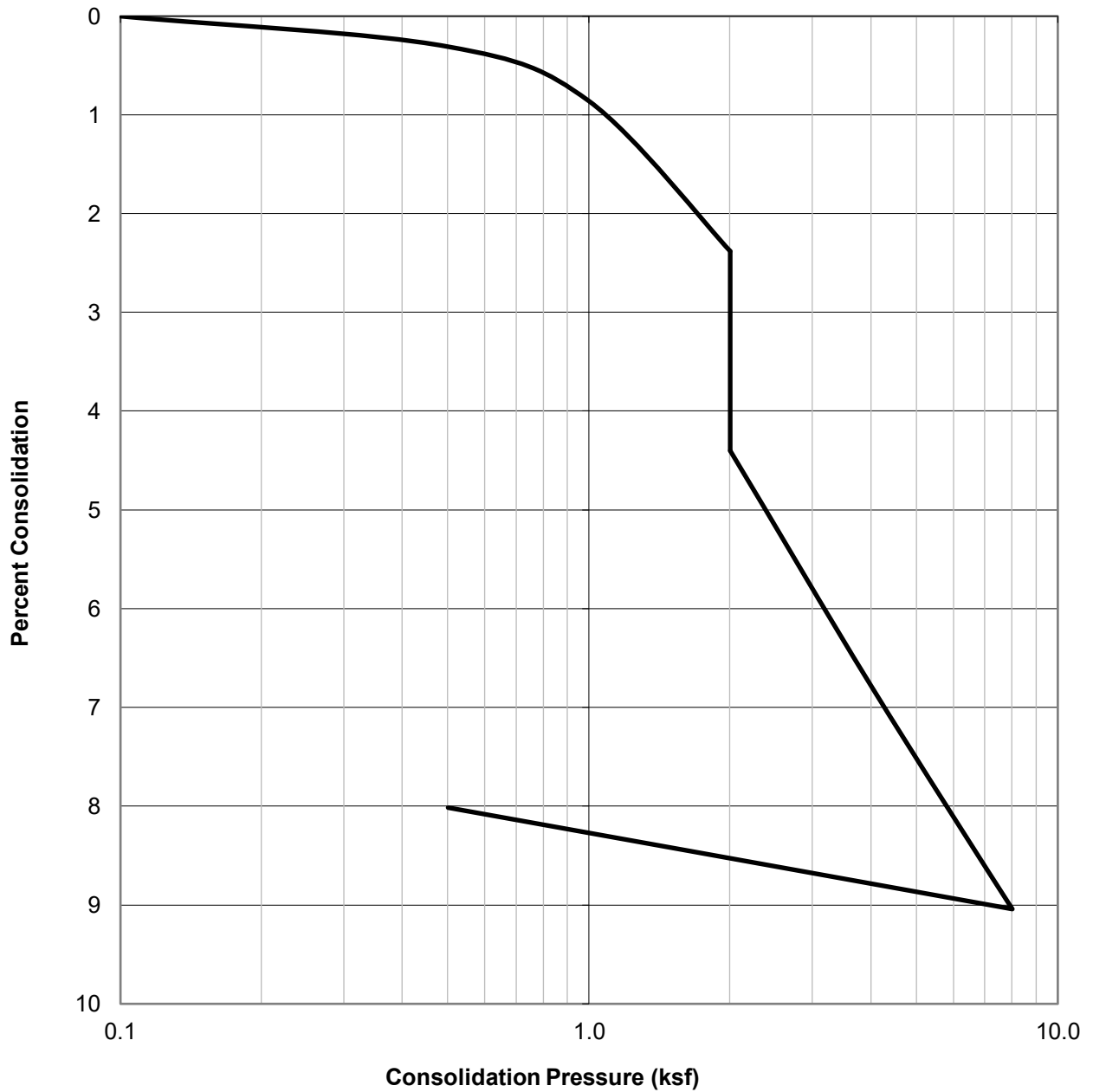

SAMPLE ID.	SOIL TYPE	DRY DENSITY (PCF)	INITIAL MOISTURE (%)	FINAL MOISTURE (%)
B2@7.5	Sandy Silt (ML)	88.3	14.5	25.4



CONSOLIDATION TEST RESULTS

ASTM D-2435

Checked by: JJK

Project No.: W1696-06-01

910 SOUTH MARIPOSA STREET
BURBANK, CALIFORNIA

JAN. 2023

Figure B9

WATER ADDED AT 2.0 KSF

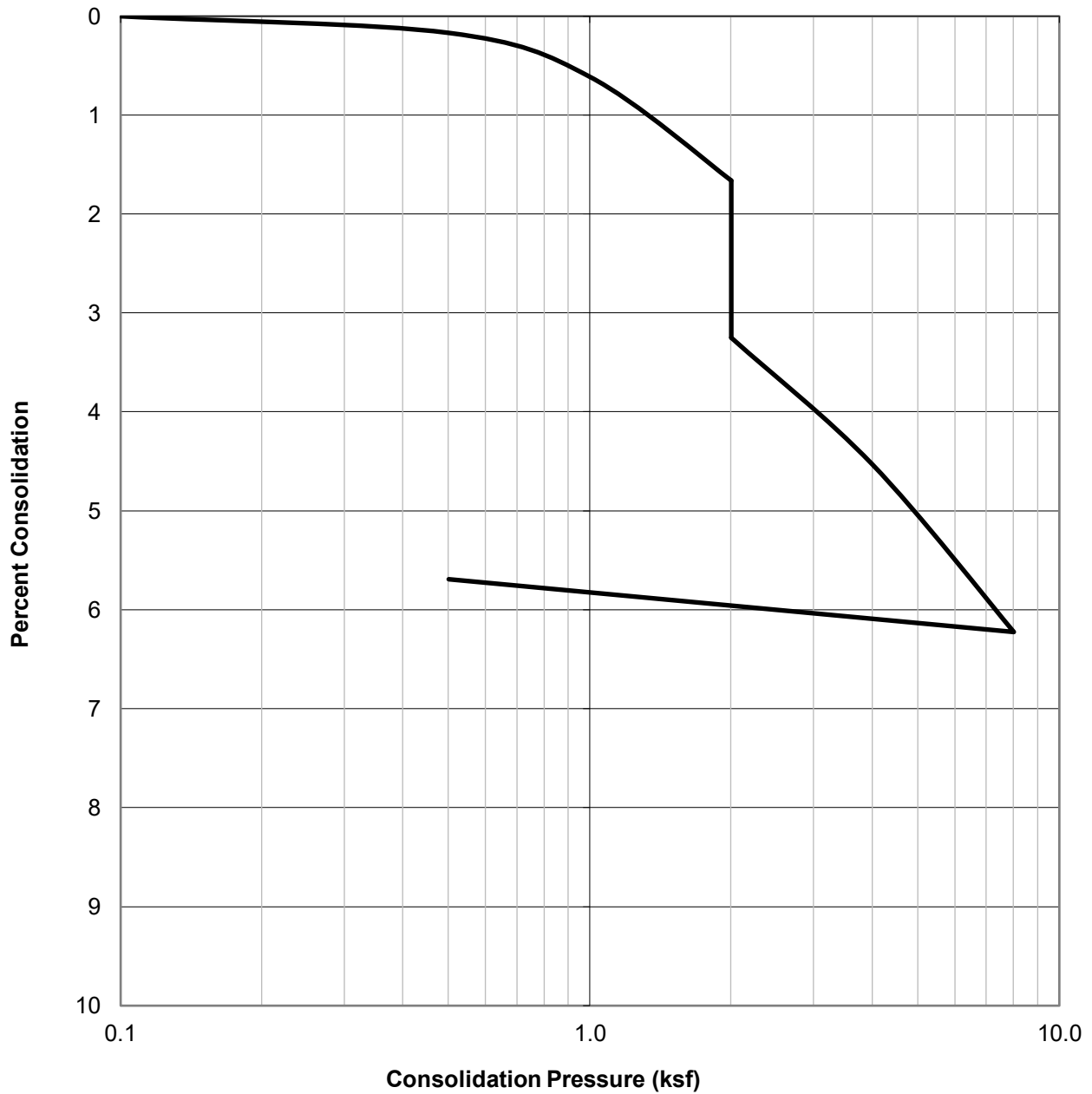

SAMPLE ID.	SOIL TYPE	DRY DENSITY (PCF)	INITIAL MOISTURE (%)	FINAL MOISTURE (%)
B2@10	Sand w/ Silt (SP-SM)	83.2	4.0	29.0



CONSOLIDATION TEST RESULTS

ASTM D-2435

Checked by: JJK

Project No.: W1696-06-01

910 SOUTH MARIPOSA STREET
BURBANK, CALIFORNIA

JAN. 2023

Figure B10

WATER ADDED AT 2.0 KSF

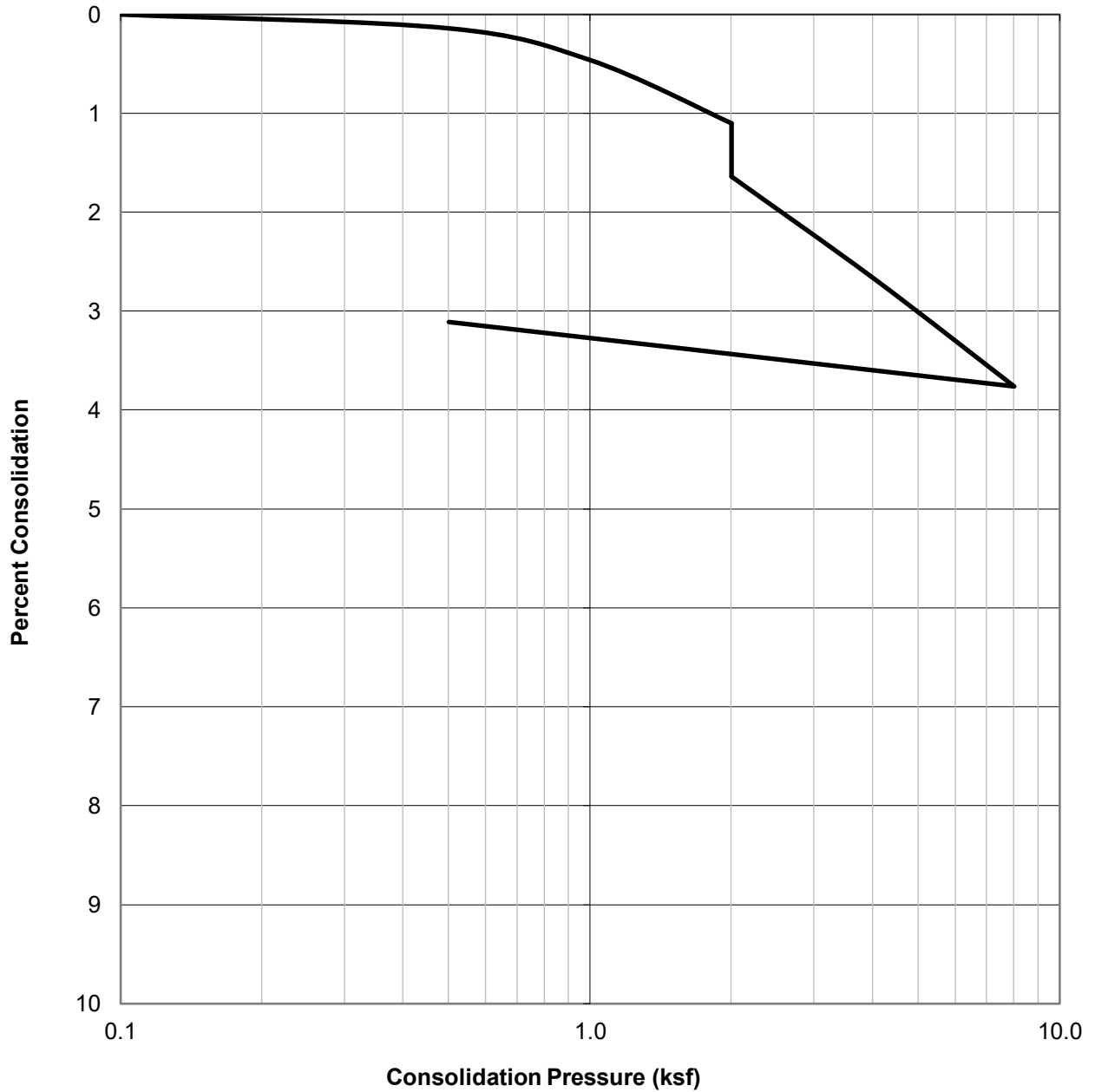

SAMPLE ID.	SOIL TYPE	DRY DENSITY (PCF)	INITIAL MOISTURE (%)	FINAL MOISTURE (%)
B2@15	Silt w/ Sand (ML)	87.9	4.8	28.2



CONSOLIDATION TEST RESULTS
 ASTM D-2435
 Checked by: JJK

Project No.: W1696-06-01
 910 SOUTH MARIPOSA STREET
 BURBANK, CALIFORNIA
 JAN. 2023 Figure B11

WATER ADDED AT 2.0 KSF

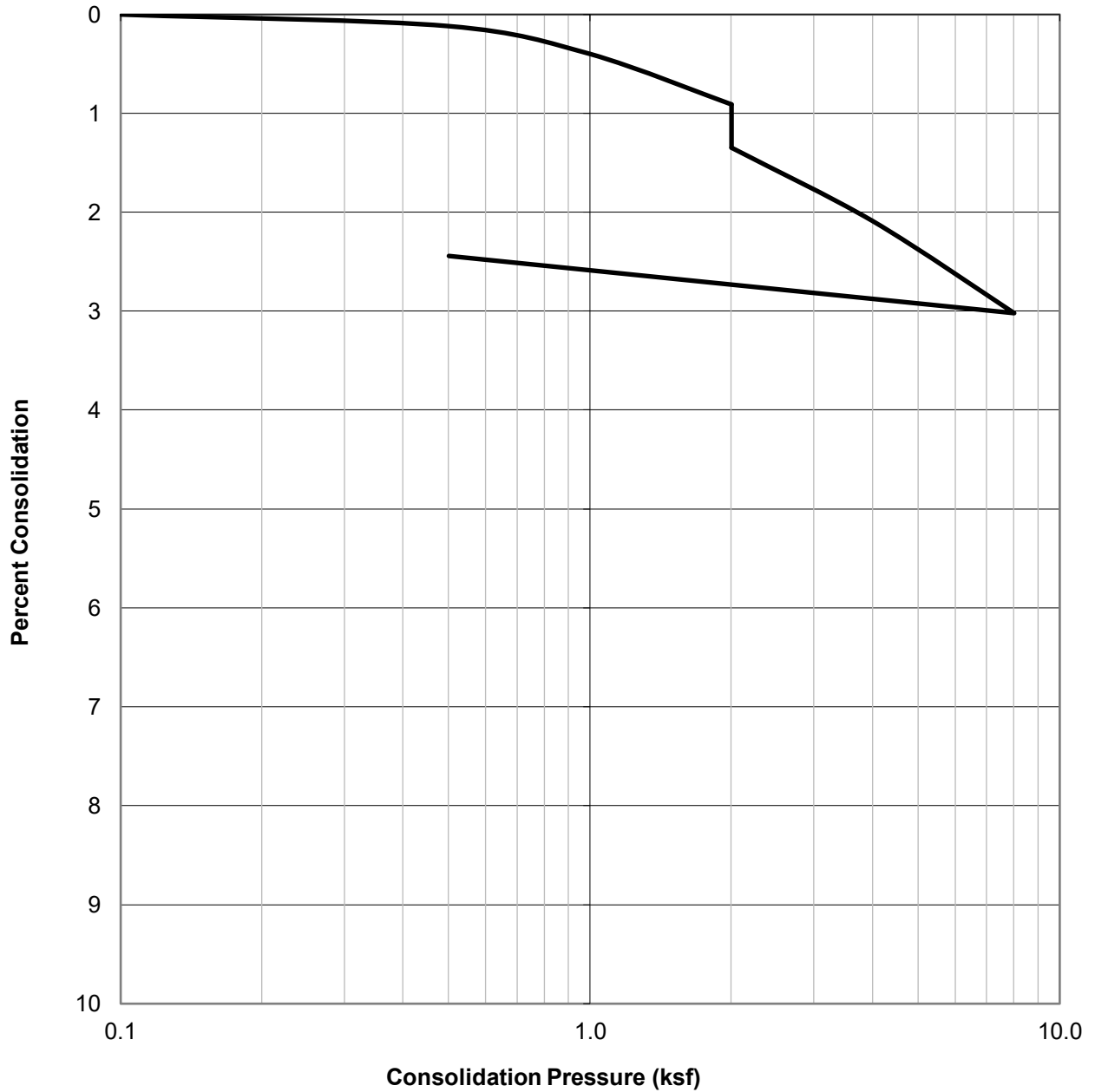

SAMPLE ID.	SOIL TYPE	DRY DENSITY (PCF)	INITIAL MOISTURE (%)	FINAL MOISTURE (%)
B2@20	Silty Sand (SM)	93.9	4.2	22.9



CONSOLIDATION TEST RESULTS

ASTM D-2435

Checked by: JJK

Project No.: W1696-06-01

910 SOUTH MARIPOSA STREET
BURBANK, CALIFORNIA

JAN. 2023

Figure B12

WATER ADDED AT 2.0 KSF

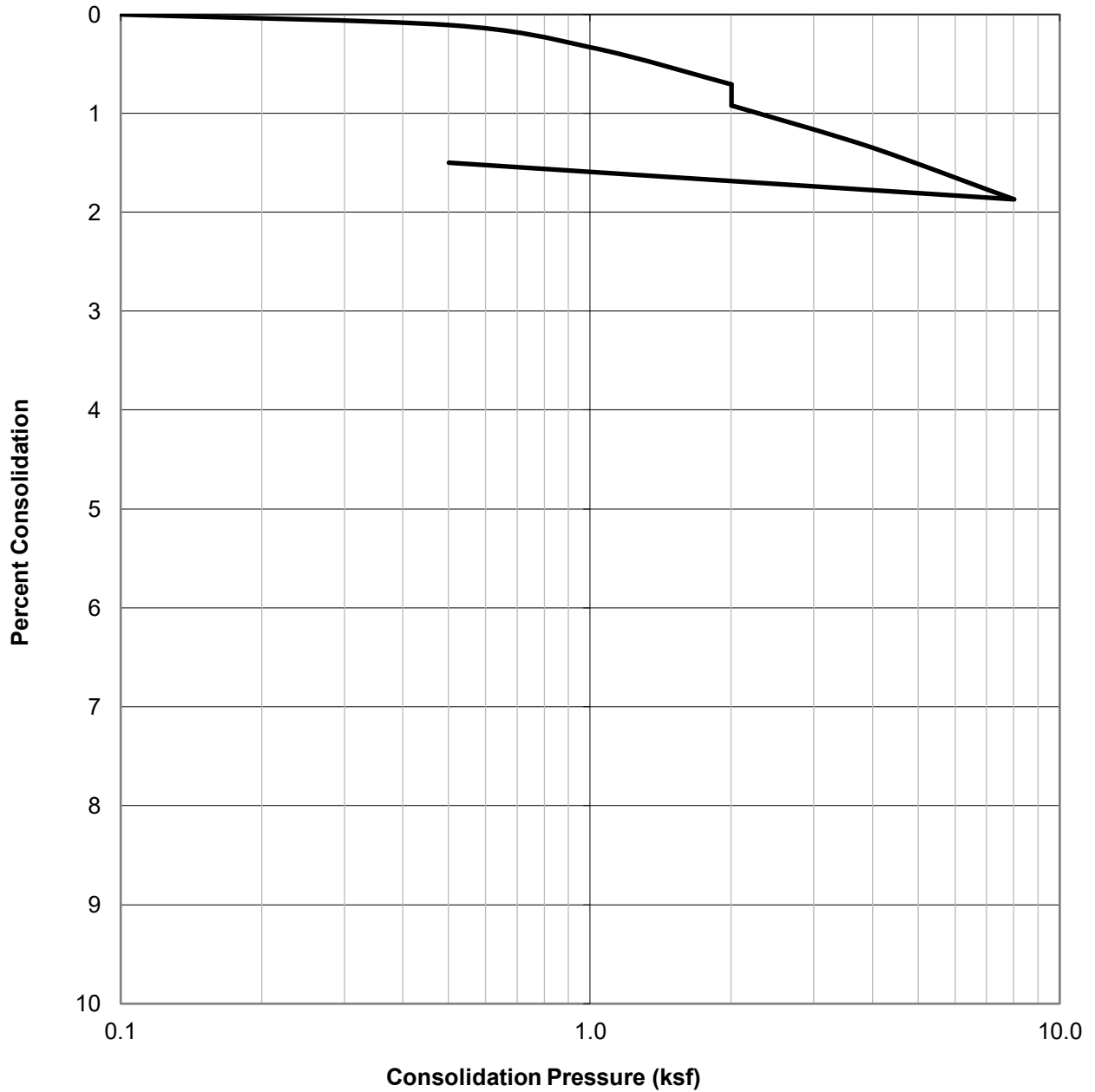

SAMPLE ID.	SOIL TYPE	DRY DENSITY (PCF)	INITIAL MOISTURE (%)	FINAL MOISTURE (%)
B2@25	Sand (SP)	103.7	3.1	19.3



CONSOLIDATION TEST RESULTS

ASTM D-2435

Checked by: JJK

Project No.: W1696-06-01

910 SOUTH MARIPOSA STREET
BURBANK, CALIFORNIA

JAN. 2023

Figure B13

WATER ADDED AT 2.0 KSF

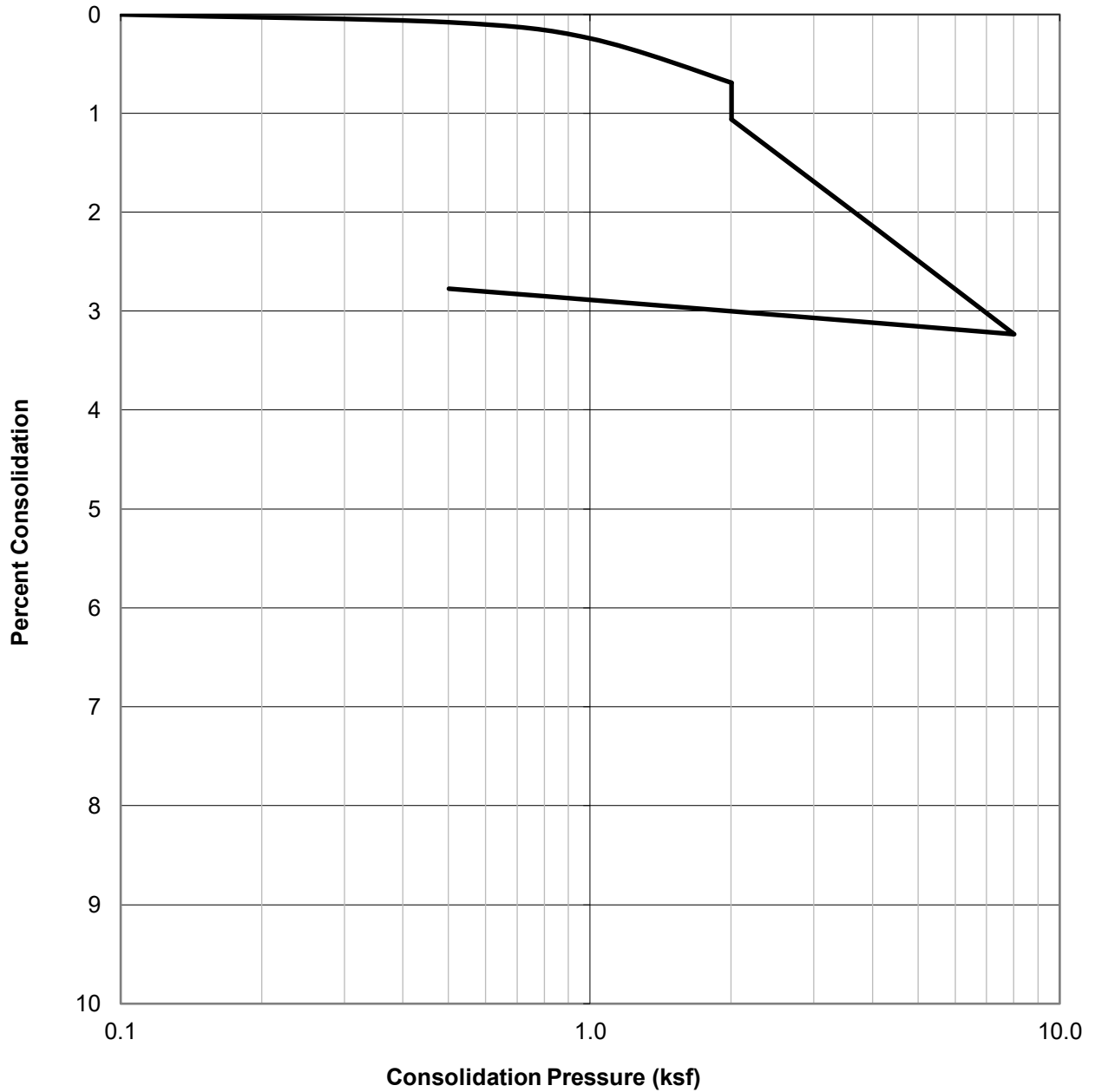

SAMPLE ID.	SOIL TYPE	DRY DENSITY (PCF)	INITIAL MOISTURE (%)	FINAL MOISTURE (%)
B2@30	Sand (SP)	105.4	2.8	16.6



CONSOLIDATION TEST RESULTS

ASTM D-2435

Checked by: JJK

Project No.: W1696-06-01

910 SOUTH MARIPOSA STREET
BURBANK, CALIFORNIA

JAN. 2023

Figure B14

WATER ADDED AT 2.0 KSF

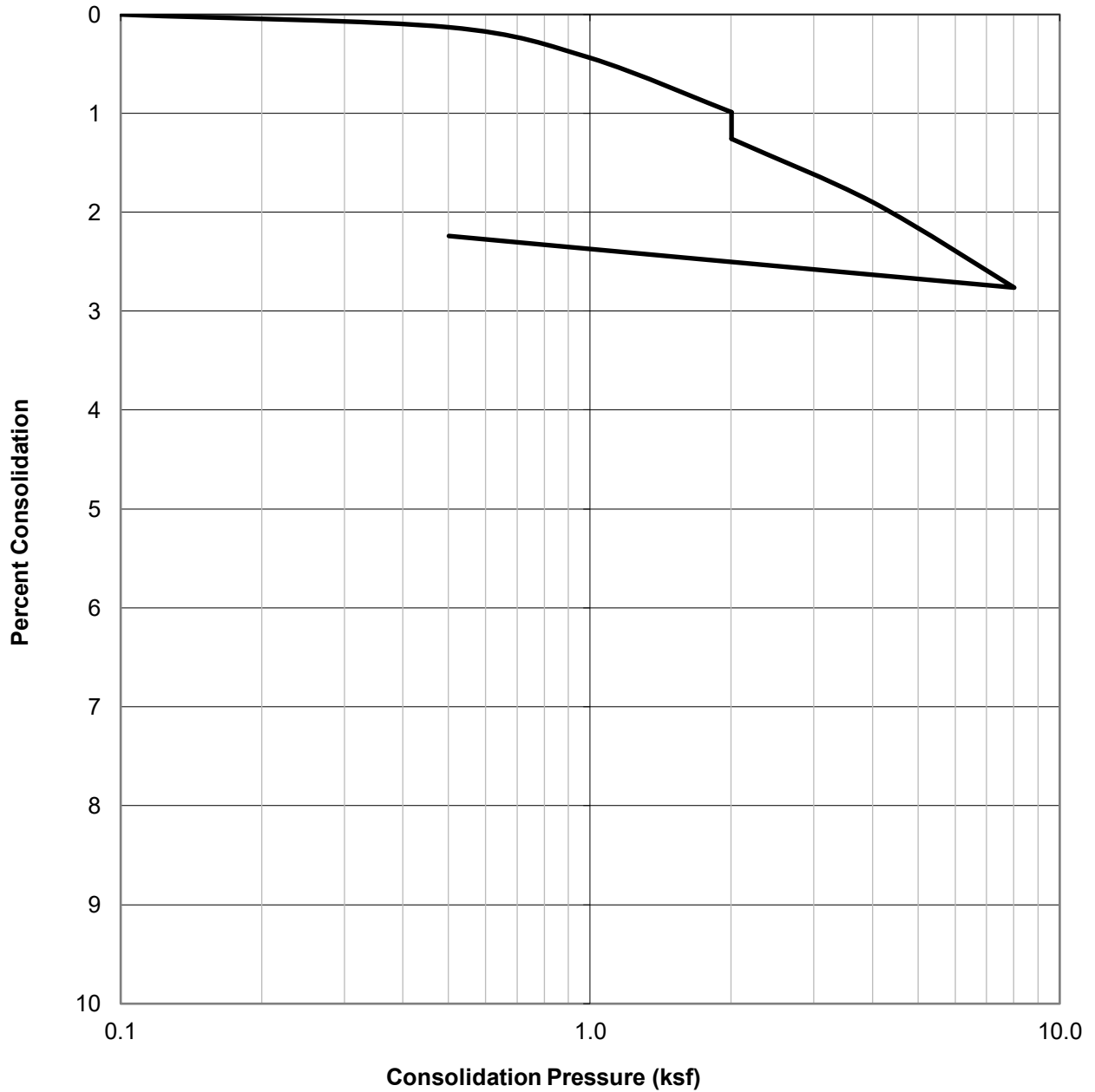

SAMPLE ID.	SOIL TYPE	DRY DENSITY (PCF)	INITIAL MOISTURE (%)	FINAL MOISTURE (%)
B2@35	Sand (SP)	98.4	2.8	22.1

	CONSOLIDATION TEST RESULTS ASTM D-2435	Project No.: W1696-06-01
	Checked by: JJK	910 SOUTH MARIPOSA STREET BURBANK, CALIFORNIA
		JAN. 2023 Figure B15

WATER ADDED AT 2.0 KSF

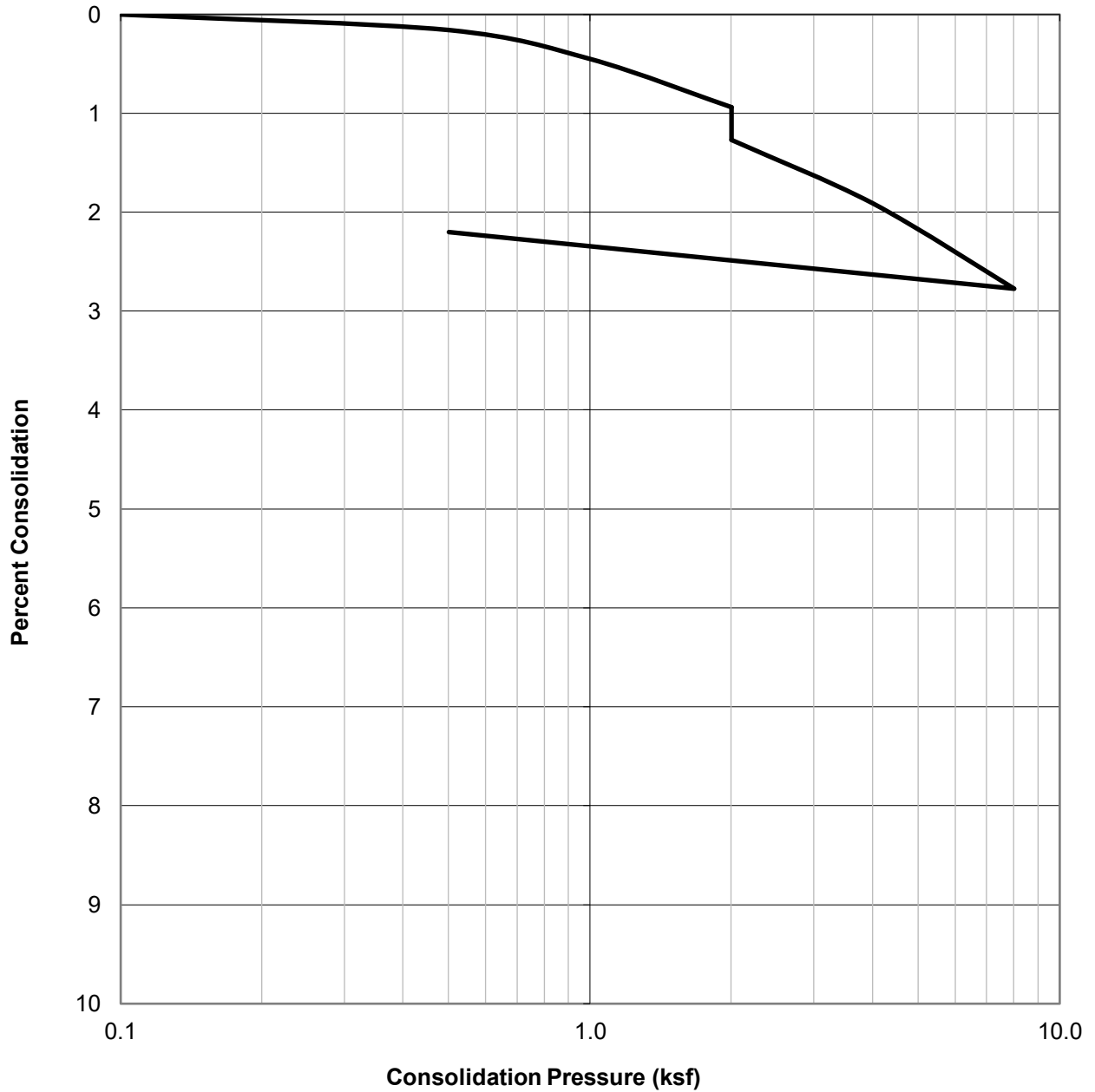

SAMPLE ID.	SOIL TYPE	DRY DENSITY (PCF)	INITIAL MOISTURE (%)	FINAL MOISTURE (%)
B3@10	Silty Sand (SM)	96.2	4.1	23.8

	CONSOLIDATION TEST RESULTS ASTM D-2435	Project No.: W1696-06-01
		910 SOUTH MARIPOSA STREET BURBANK, CALIFORNIA
	Checked by: JJK	JAN. 2023

WATER ADDED AT 2.0 KSF

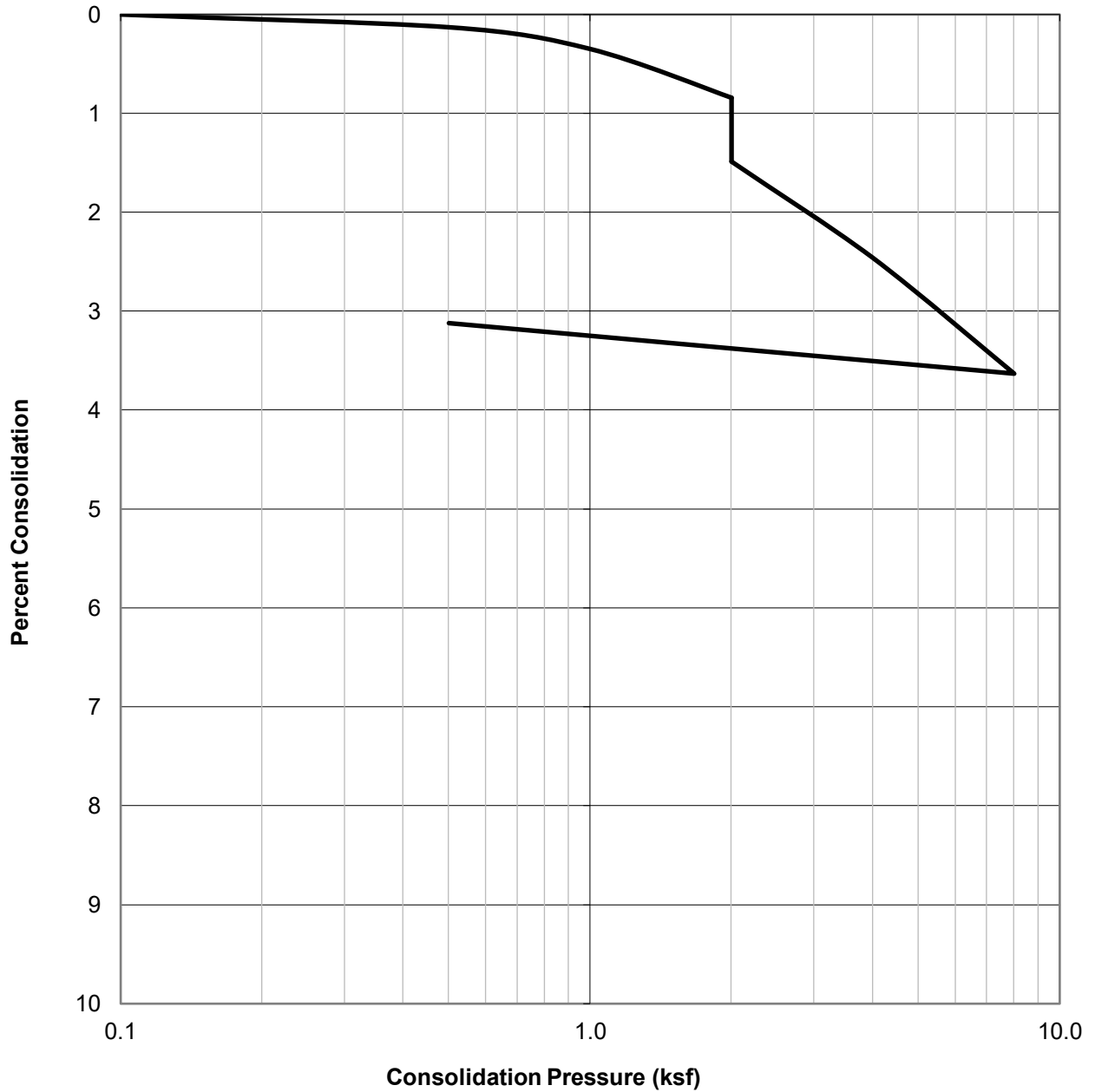

SAMPLE ID.	SOIL TYPE	DRY DENSITY (PCF)	INITIAL MOISTURE (%)	FINAL MOISTURE (%)
B3@20	Sand w/ Silt (SP-SM)	97.5	5.1	18.7

	CONSOLIDATION TEST RESULTS ASTM D-2435	Project No.: W1696-06-01
	Checked by: JJK	910 SOUTH MARIPOSA STREET BURBANK, CALIFORNIA
	JAN. 2023	Figure B17

WATER ADDED AT 2.0 KSF

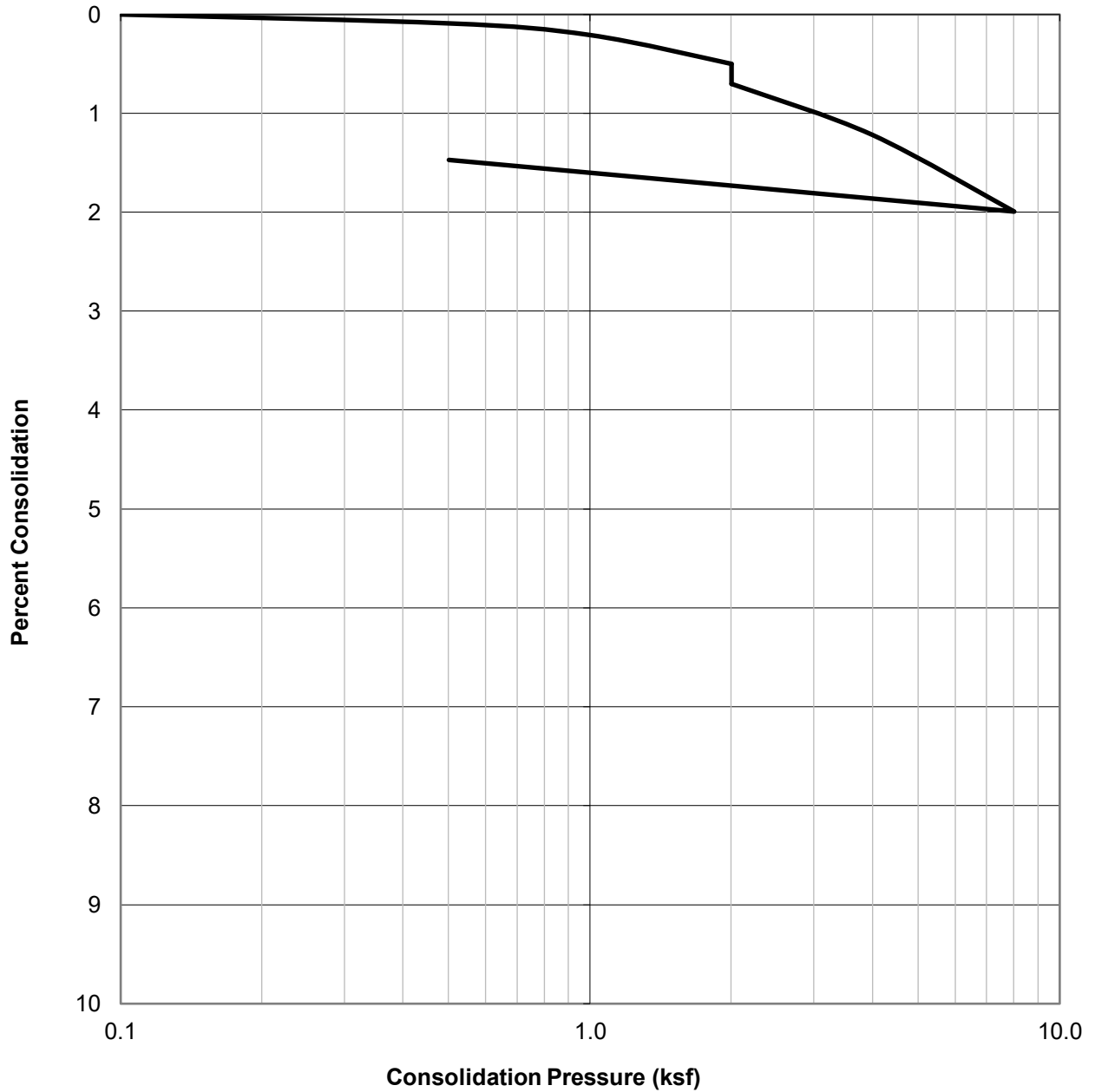

SAMPLE ID.	SOIL TYPE	DRY DENSITY (PCF)	INITIAL MOISTURE (%)	FINAL MOISTURE (%)
B4@6	Sand w/ Silt (SP-SM)	93.5	3.9	24.4



CONSOLIDATION TEST RESULTS

ASTM D-2435

Checked by: JJK

Project No.: W1696-06-01

910 SOUTH MARIPOSA STREET
BURBANK, CALIFORNIA

JAN. 2023

Figure B18

WATER ADDED AT 2.0 KSF

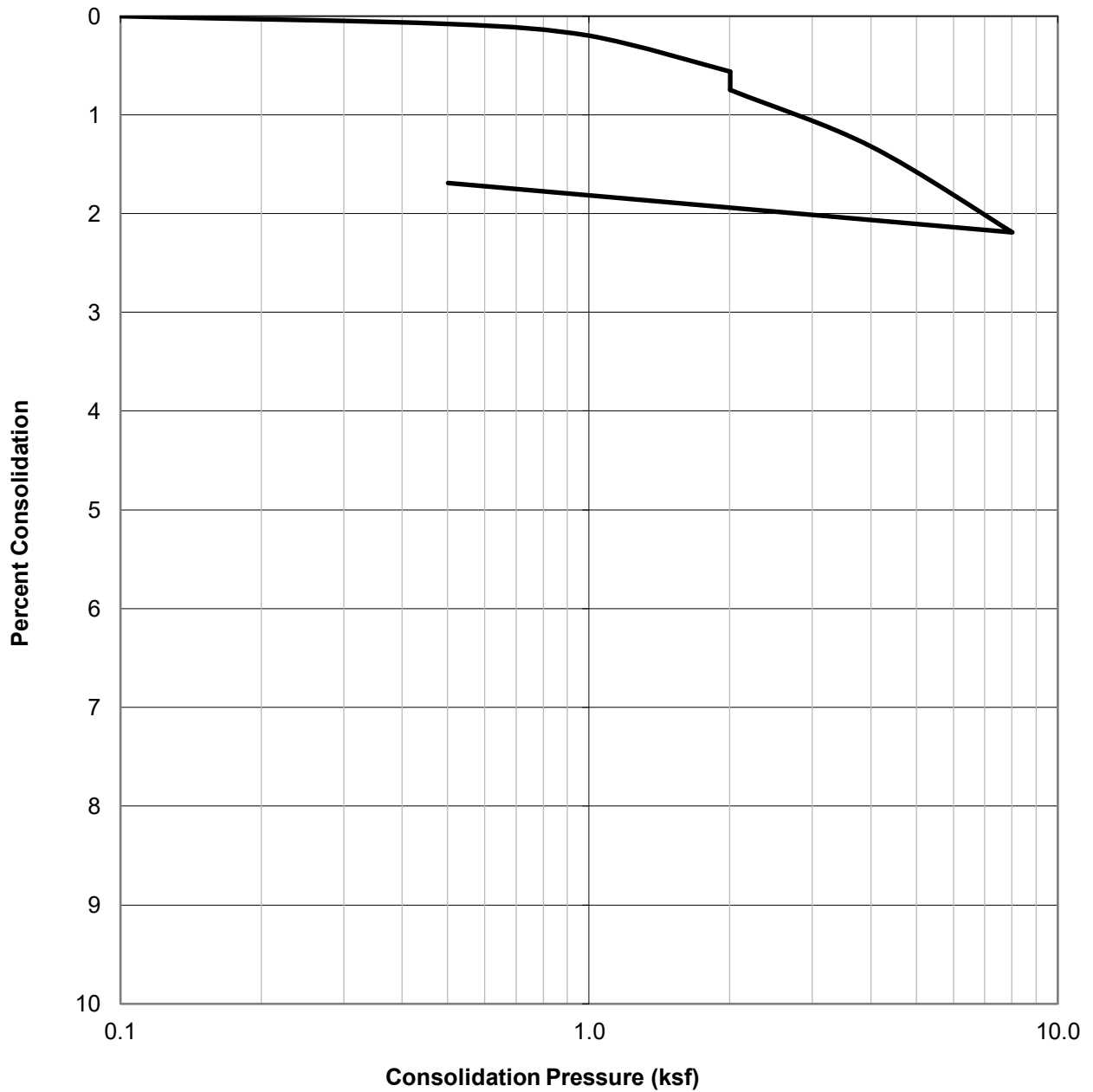

SAMPLE ID.	SOIL TYPE	DRY DENSITY (PCF)	INITIAL MOISTURE (%)	FINAL MOISTURE (%)
B4@10	Sand w/ Silt (SP-SM)	91.2	4.1	26.9

	CONSOLIDATION TEST RESULTS <small>ASTM D-2435</small>	Project No.: W1696-06-01
	Checked by: JJK	910 SOUTH MARIPOSA STREET BURBANK, CALIFORNIA
	JAN. 2023	Figure B19

WATER ADDED AT 2.0 KSF

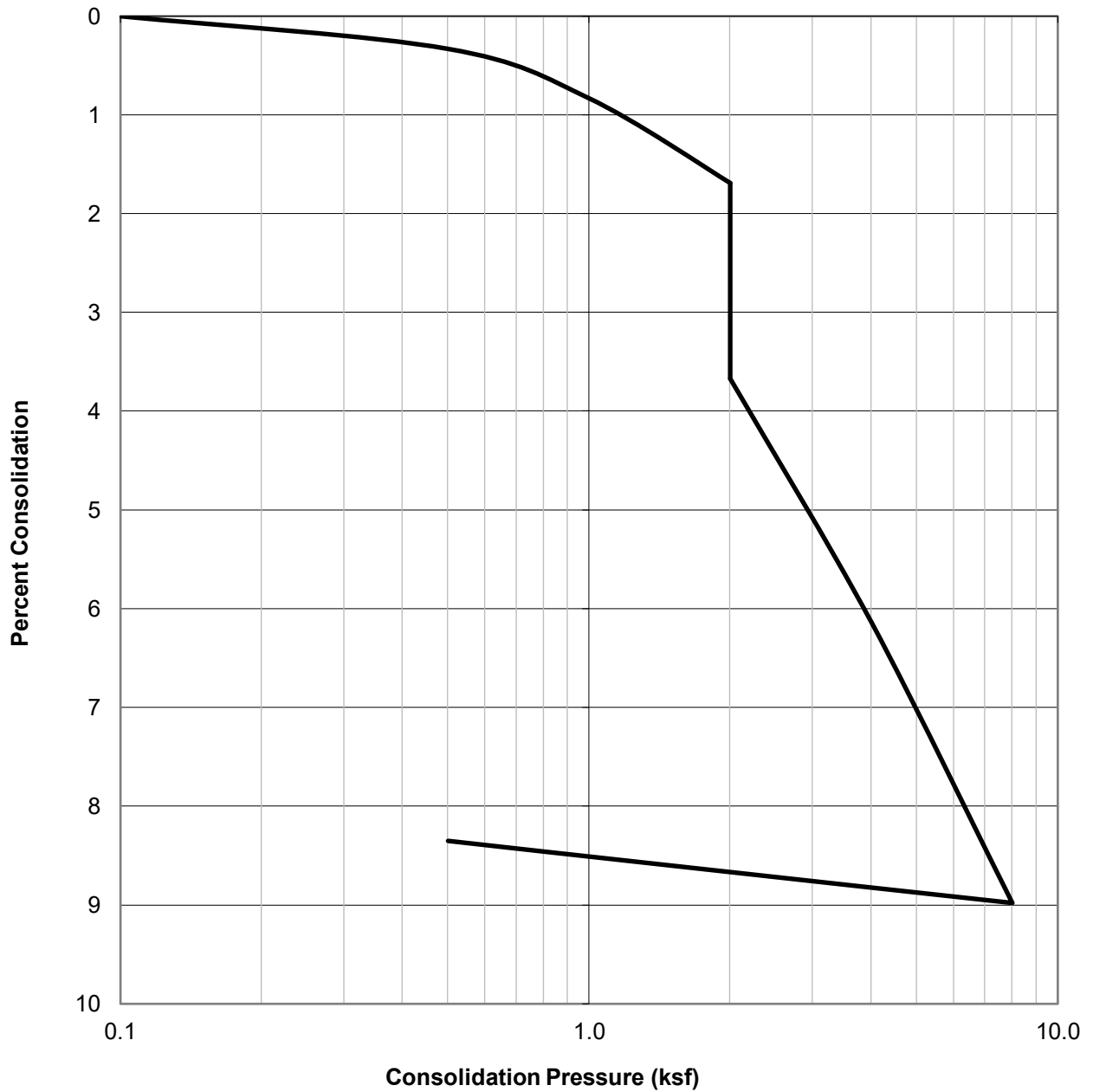

SAMPLE ID.	SOIL TYPE	DRY DENSITY (PCF)	INITIAL MOISTURE (%)	FINAL MOISTURE (%)
B5@5.5	Silty Sand (SM)	100.5	7.7	19.0



CONSOLIDATION TEST RESULTS
 ASTM D-2435
 Checked by: JJK

Project No.: W1696-06-01
 910 SOUTH MARIPOSA STREET
 BURBANK, CALIFORNIA
 JAN. 2023 Figure B20

WATER ADDED AT 2.0 KSF

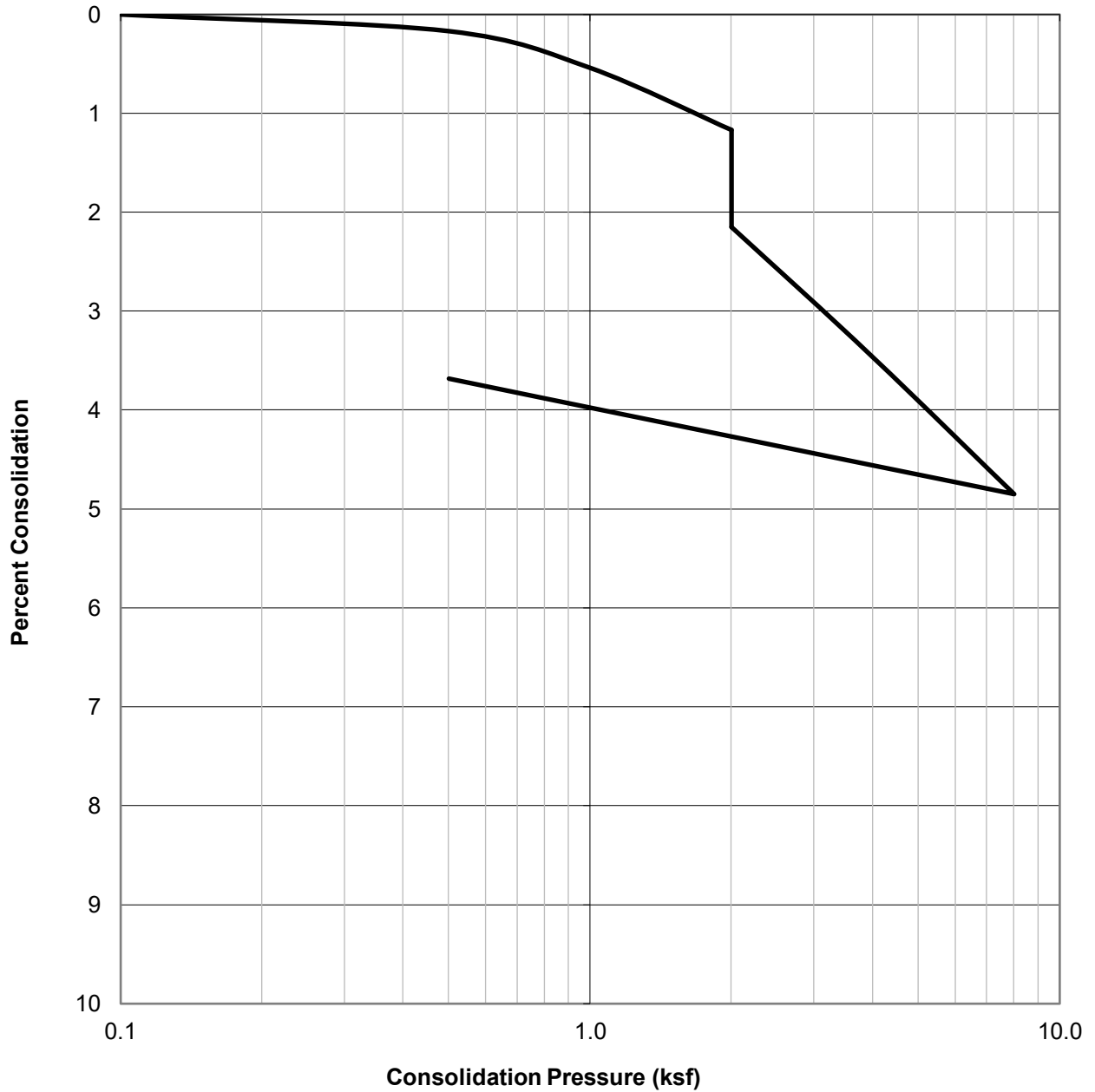

SAMPLE ID.	SOIL TYPE	DRY DENSITY (PCF)	INITIAL MOISTURE (%)	FINAL MOISTURE (%)
B5@9.5	Silty Sand (SM)	90.4	6.5	26.5



CONSOLIDATION TEST RESULTS
 ASTM D-2435
 Checked by: JJK

Project No.: W1696-06-01
 910 SOUTH MARIPOSA STREET
 BURBANK, CALIFORNIA
 JAN. 2023 Figure B21

WATER ADDED AT 2.0 KSF

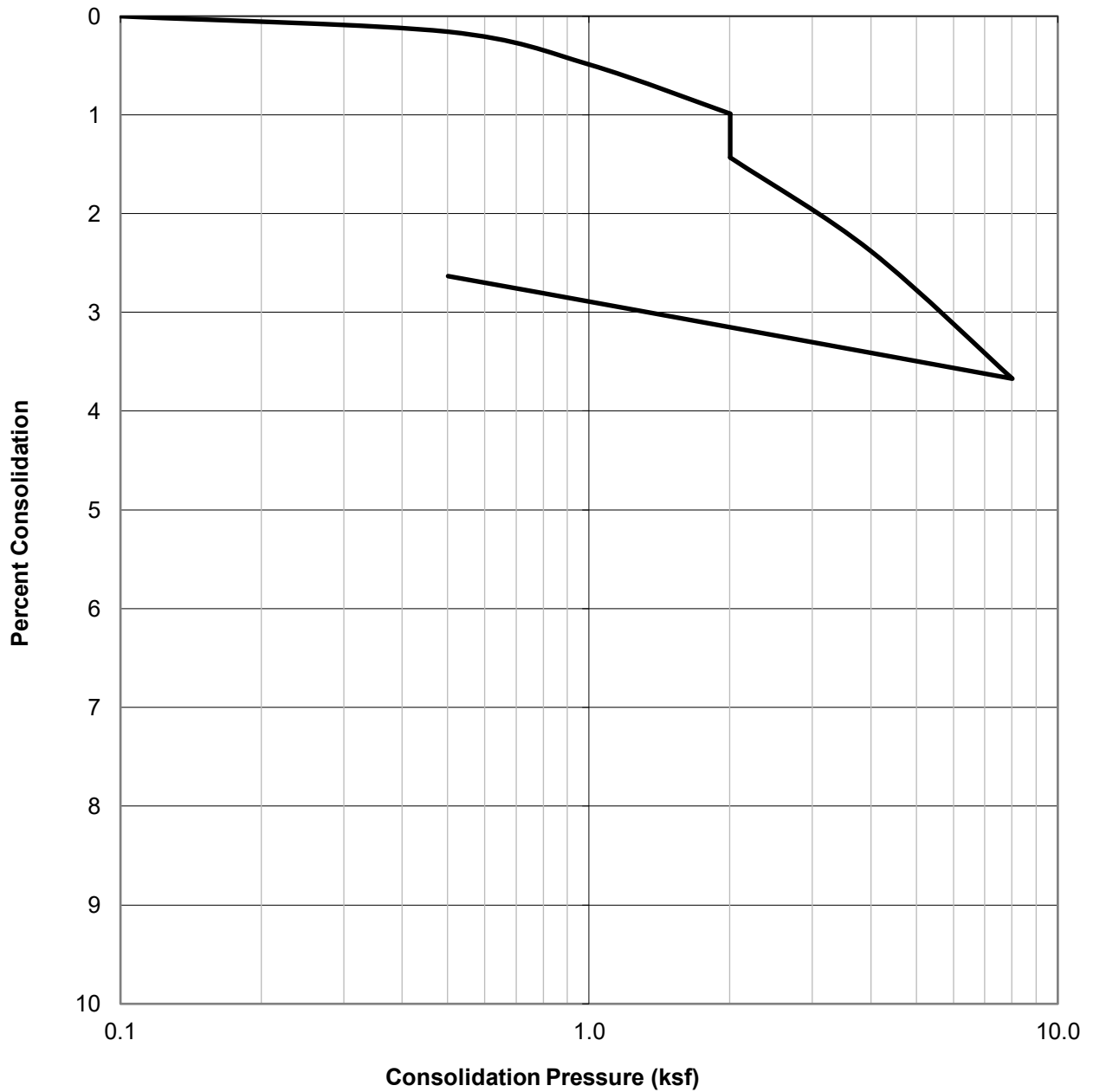

SAMPLE ID.	SOIL TYPE	DRY DENSITY (PCF)	INITIAL MOISTURE (%)	FINAL MOISTURE (%)
B5@12	Silty Sand (SM)	86.2	6.7	29.8

	CONSOLIDATION TEST RESULTS ASTM D-2435	Project No.: W1696-06-01
	Checked by: JJK	910 SOUTH MARIPOSA STREET BURBANK, CALIFORNIA
		JAN. 2023

GRAVEL		SAND			SILT AND CLAY
COARSE	FINE	COARSE	MEDIUM	FINE	

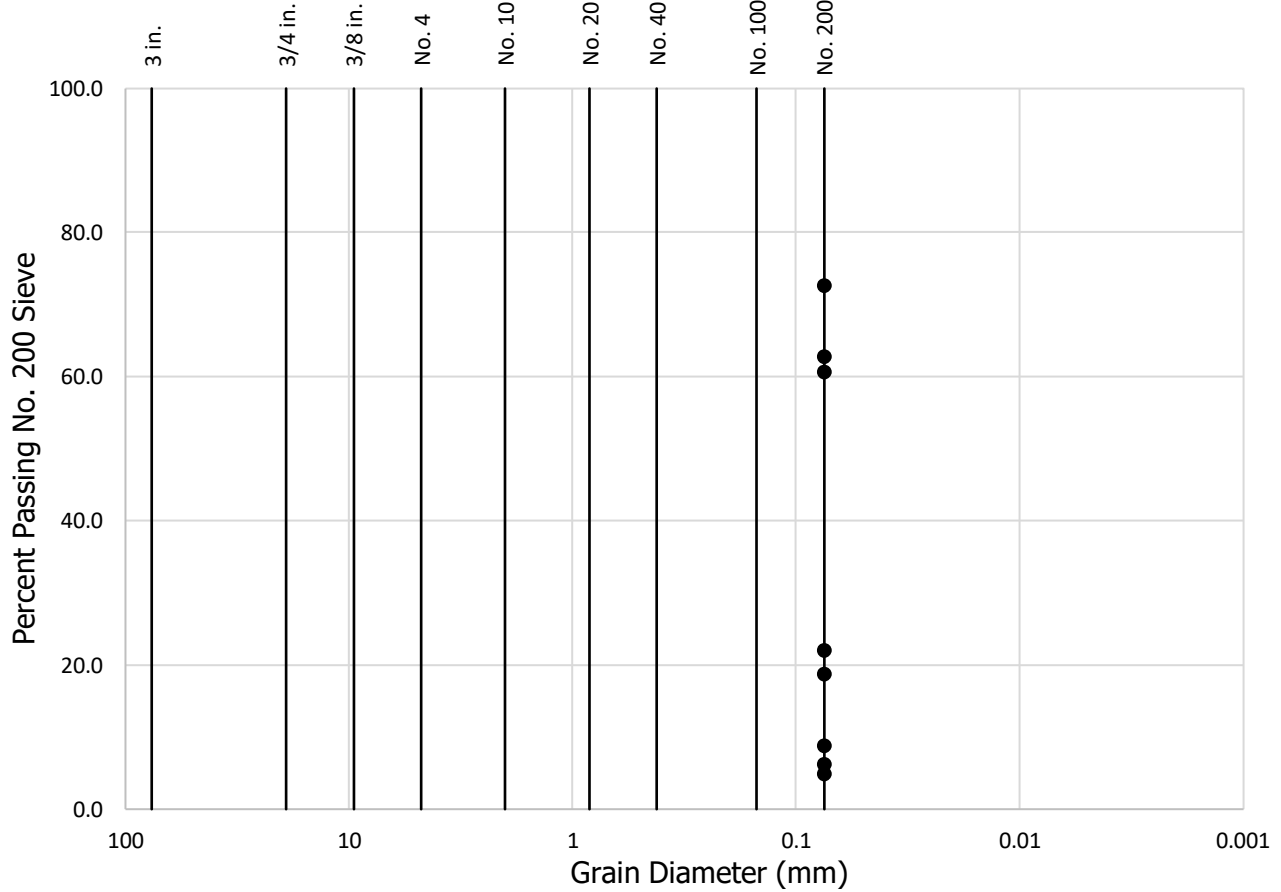

Sample No.	Percent Passing No. 200 Sieve
B1 @ 5'	62.8
B1 @ 10'	18.7
B1 @ 14.5'	22.1
B1 @ 19.5'	8.8
B1 @ 25'	4.9
B2 @ 4'	60.7
B2 @ 10'	6.2
B2 @ 12'	72.7



GRAIN SIZE ANALYSIS

ASTM D-1140

Checked by: JJK

Project No.: W1696-06-01

910 SOUTH MARIPOSA STREET
BURBANK, CALIFORNIA

JAN. 2023

Figure B23

GRAVEL		SAND			SILT AND CLAY
COARSE	FINE	COARSE	MEDIUM	FINE	

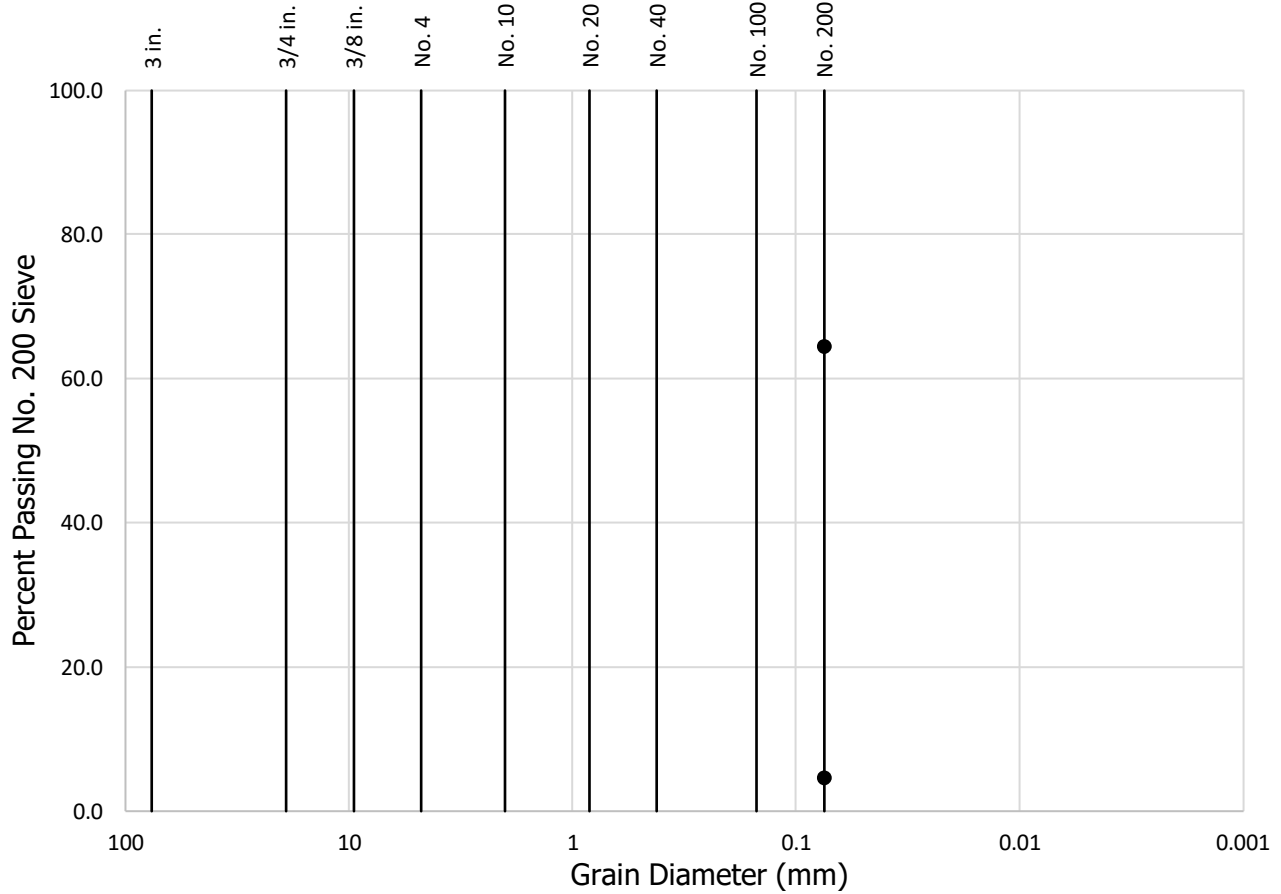

Sample No.	Percent Passing No. 200 Sieve
B2 @ 17.5'	64.5
B2 @ 22.5'	4.6



GRAIN SIZE ANALYSIS

ASTM D-1140

Checked by: JJK

Project No.: W1696-06-01

910 SOUTH MARIPOSA STREET
BURBANK, CALIFORNIA

JAN. 2023

Figure B24

Sample No:

B1@0-5'	Sandy Silt (ML)
----------------	-----------------

TEST NO.		1	2	3	4	5	6
Wt. Compacted Soil + Mold	(g)	6155	6218	6242	6187		
Weight of Mold	(g)	4208	4208	4208	4208		
Net Weight of Soil	(g)	1948	2010	2034	1979		
Wet Weight of Soil + Cont.	(g)	649.3	704.4	646.9	675.5		
Dry Weight of Soil + Cont.	(g)	608.9	650.3	589.5	606.2		
Weight of Container	(g)	124.8	134.0	125.2	126.5		
Moisture Content	(%)	8.4	10.5	12.4	14.4		
Wet Density	(pcf)	128.9	133.0	134.6	131.0		
Dry Density	(pcf)	119.0	120.4	119.8	114.5		

Maximum Dry Density (pcf) 121.0

Optimum Moisture Content (%) 11.5

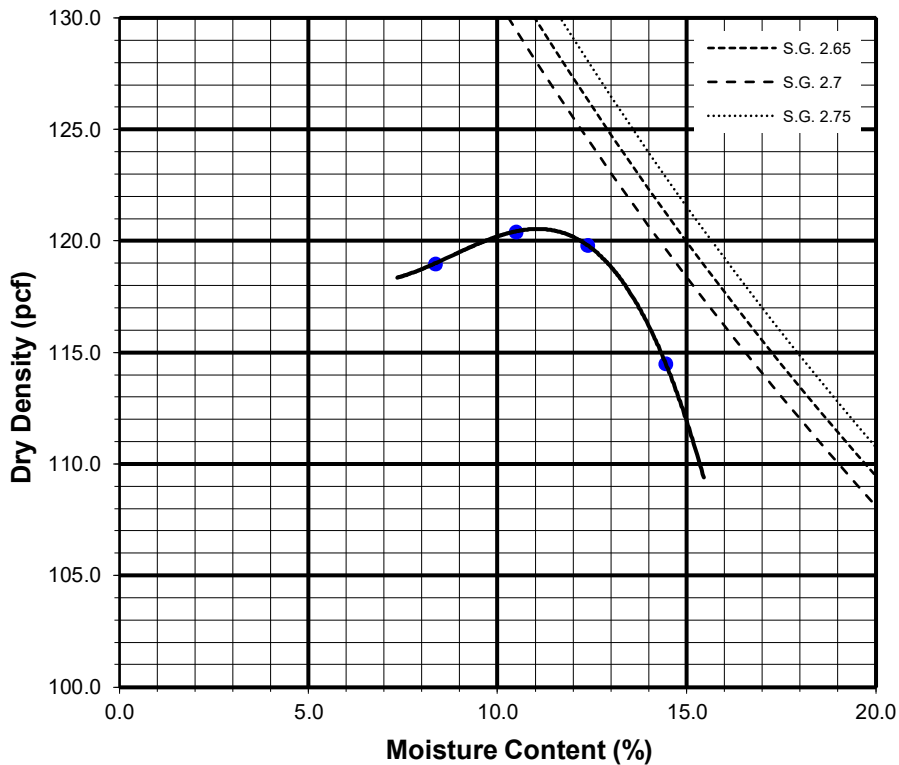

Preparation Method: A

	COMPACTION CHARACTERISTICS USING MODIFIED EFFORT TEST RESULTS <small>ASTM D-1557</small>	Project No.: W1696-06-01
	Checked by: JJK	910 SOUTH MARIPOSA STREET BURBANK, CALIFORNIA JAN. 2023 Figure B25

Sample No:

B4+B5@0-5'	Silty Sand (SM)
-------------------	-----------------

TEST NO.		1	2	3	4	5	6
Wt. Compacted Soil + Mold	(g)	6177	6243	6287	6242		
Weight of Mold	(g)	4208	4208	4208	4208		
Net Weight of Soil	(g)	1969	2035	2079	2034		
Wet Weight of Soil + Cont.	(g)	735.4	722.7	680.3	707.3		
Dry Weight of Soil + Cont.	(g)	696.2	673.8	624.2	639.9		
Weight of Container	(g)	145.2	148.3	125.8	136.3		
Moisture Content	(%)	7.1	9.3	11.3	13.4		
Wet Density	(pcf)	130.3	134.7	137.6	134.7		
Dry Density	(pcf)	121.7	123.3	123.7	118.8		

Maximum Dry Density (pcf) 124.0

Optimum Moisture Content (%) 10.5

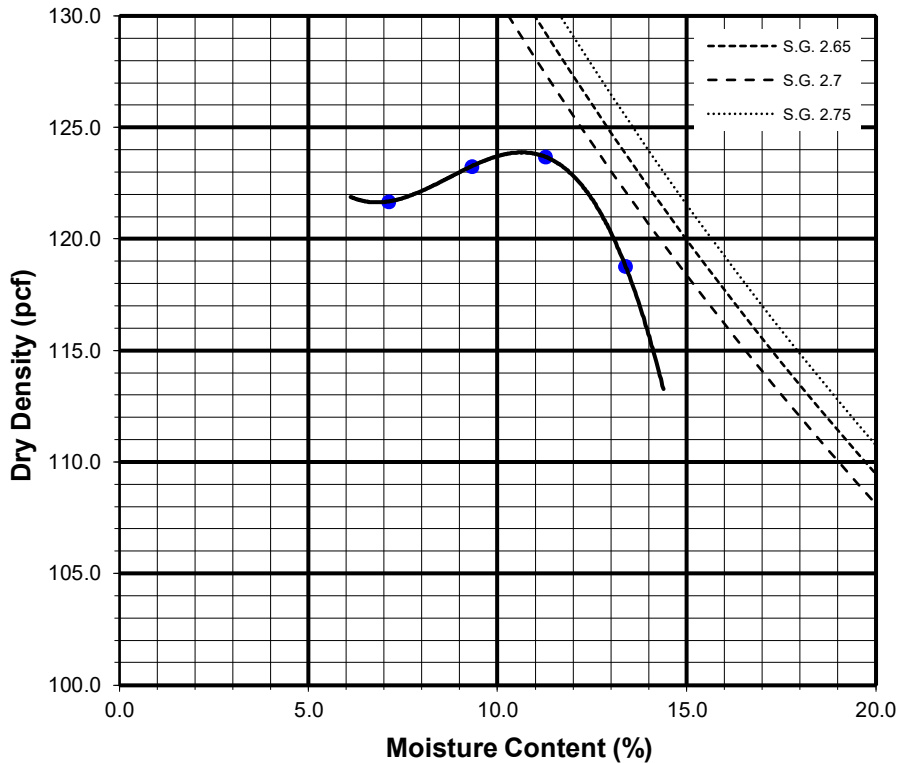

Preparation Method: A

	COMPACTION CHARACTERISTICS USING MODIFIED EFFORT TEST RESULTS	Project No.: W1696-06-01
	ASTM D-1557	910 SOUTH MARIPOSA STREET BURBANK, CALIFORNIA
	Checked by: JJK	JAN. 2023 Figure B26

B1@0-5'

MOLDED SPECIMEN		BEFORE TEST	AFTER TEST
Specimen Diameter	(in.)	4.0	4.0
Specimen Height	(in.)	1.0	1.0
Wt. Comp. Soil + Mold	(gm)	758.9	761.4
Wt. of Mold	(gm)	367.5	367.5
Specific Gravity	(Assumed)	2.7	2.7
Wet Wt. of Soil + Cont.	(gm)	491.9	761.4
Dry Wt. of Soil + Cont.	(gm)	461.7	352.0
Wt. of Container	(gm)	191.9	367.5
Moisture Content	(%)	11.2	11.9
Wet Density	(pcf)	118.1	118.7
Dry Density	(pcf)	106.2	106.0
Void Ratio		0.6	0.6
Total Porosity		0.4	0.4
Pore Volume	(cc)	76.6	76.6
Degree of Saturation	(%) [S_{meas}]	51.8	54.7

Date	Time	Pressure (psi)	Elapsed Time (min)	Dial Readings (in.)
12/14/2022	10:00	1.0	0	0.286
12/14/2022	10:10	1.0	10	0.285
Add Distilled Water to the Specimen				
12/15/2022	10:00	1.0	1430	0.285
12/15/2022	11:00	1.0	1490	0.285

Expansion Index (EI meas) =	0
Expansion Index (Report) =	0

Expansion Index, EI_{50}	CBC CLASSIFICATION *	UBC CLASSIFICATION **
0-20	Non-Expansive	Very Low
21-50	Expansive	Low
51-90	Expansive	Medium
91-130	Expansive	High
>130	Expansive	Very High

* Reference: 2019 California Building Code, Section 1803.5.3

** Reference: 1997 Uniform Building Code, Table 18-I-B.

	EXPANSION INDEX TEST RESULTS	Project No.: W1696-06-01
	ASTM D-4829	910 SOUTH MARIPOSA STREET BURBANK, CALIFORNIA
	Checked by: JJK	JAN. 2023 Figure B27

B4+B5@0-5'

MOLDED SPECIMEN		BEFORE TEST	AFTER TEST
Specimen Diameter	(in.)	4.0	4.0
Specimen Height	(in.)	1.0	1.0
Wt. Comp. Soil + Mold	(gm)	770.9	784.9
Wt. of Mold	(gm)	368.0	368.0
Specific Gravity	(Assumed)	2.7	2.7
Wet Wt. of Soil + Cont.	(gm)	491.9	784.9
Dry Wt. of Soil + Cont.	(gm)	465.9	367.9
Wt. of Container	(gm)	191.9	368.0
Moisture Content	(%)	9.5	13.3
Wet Density	(pcf)	121.5	125.6
Dry Density	(pcf)	111.0	110.8
Void Ratio		0.5	0.5
Total Porosity		0.3	0.3
Pore Volume	(cc)	70.7	70.7
Degree of Saturation	(%) [S_{meas}]	49.8	69.3

Date	Time	Pressure (psi)	Elapsed Time (min)	Dial Readings (in.)
12/13/2022	10:00	1.0	0	0.303
12/13/2022	10:10	1.0	10	0.3015
Add Distilled Water to the Specimen				
12/14/2022	10:00	1.0	1430	0.3015
12/14/2022	11:00	1.0	1490	0.3015

Expansion Index (EI meas) =	0
Expansion Index (Report) =	0

Expansion Index, EI_{50}	CBC CLASSIFICATION *	UBC CLASSIFICATION **
0-20	Non-Expansive	Very Low
21-50	Expansive	Low
51-90	Expansive	Medium
91-130	Expansive	High
>130	Expansive	Very High

* Reference: 2019 California Building Code, Section 1803.5.3

** Reference: 1997 Uniform Building Code, Table 18-I-B.

 GEOCON	EXPANSION INDEX TEST RESULTS ASTM D-4829	Project No.: W1696-06-01
	Checked by: JJK	910 SOUTH MARIPOSA STREET BURBANK, CALIFORNIA
		JAN. 2023

SUMMARY OF LABORATORY
 POTENTIAL OF HYDROGEN (pH) AND RESISTIVITY TEST RESULTS
 AASHTO T289 ASTM D4972 and AASHTO T288 ASTM G187

Sample No.	pH	Resistivity (ohm centimeters)
B2@0-5'	8.3	690 (Severely Corrosive)

SUMMARY OF LABORATORY CHLORIDE CONTENT TEST RESULTS
 AASHTO T291 ASTM C1218

Sample No.	Chloride Ion Content (%)
B2@0-5'	0.039

SUMMARY OF LABORATORY WATER SOLUBLE SULFATE TEST RESULTS
 AASHTO T290 ASTM C1580

Sample No.	Water Soluble Sulfate (% SO ₄)	Sulfate Exposure
B2@0-5'	0.027	S0

 GEOCON	CORROSIVITY TEST RESULTS	Project No.: W1696-06-01
	Checked by: JJK	910 SOUTH MARIPOSA STREET BURBANK, CALIFORNIA
		JAN. 2023 Figure B29